

# JABATAN BEKALAN AIR LUAR BANDAR SARAWAK



## TECHNICAL GUIDELINES

### WATER SUPPLY SYSTEMS

Edition  
2024

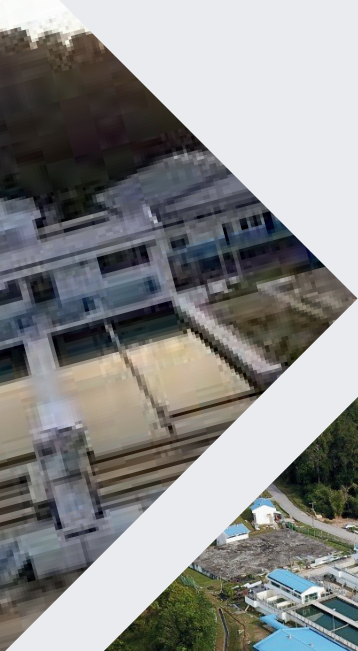

## ACKNOWLEDGEMENTS

---

1. Ir. Ts. Awg Mohammad Fadillah Bin Awg Redzuan Director (Present)
2. Ir. Chang Kuet Shian Former Director (2017-2023)
3. Thomas Lucas Santang Deputy Director (Technical)
4. Ts. Ahmad Selihin bin Che Said Deputy Director (Operation)
5. Ts. Kueh Li Li Technical Coordinator
6. Ir. George Lee Chun Lung Former Regional Manager (2016-2023)
7. Ir. Ts. Tie Tung Ing Regional Manager
8. Ir. Awang Ariffin bin Awang Bujang Regional Manager
9. Ir. Lau Chong Choon Ag. Regional Manager
10. Ts. Robert Heng Wei Kiong Assistant Regional Manager
11. Dianne Andrew Jau Senior Assistant Director
12. Ts. Aaron Gorino Senior Assistant Director
13. Ir. Ts. Bernard Wong Shuen Yuan Senior Assistant Director
14. Ir. Chhoa Chia Yee Senior Assistant Director
15. Zait Aima Yuinzy binti Yacub Senior Assistant Director
16. Nawai Ak Langar Senior Assistant Director
17. Anwarul Adzizi bin Adeni Senior Assistant Director
18. Gracie Chong Shih Chin Senior Assistant Director
19. Ts. Mohd Muazzam Bin Borhan Assistant Director
20. Nurul Affida Binti Rasdi Assistant Director
21. Oon Yin Wee Assistant Director
22. Intan Nurhafizah Fazriana Assistant Director
23. Phyliscia Audrey Ak Philip Mechanical Engineer

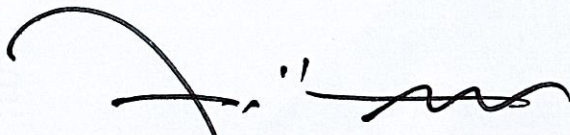

---

Ir. Ts. Awg Mohammad Fadillah Bin Awg Redzuan  
Director  
Rural Water Supply Department  
January 2024

## Abbreviation

AC	Alternating Current
API	Application Programming Interface
BOMBA	Fire and Rescue Department of Malaysia
BPS	Booster Pump Station
BRC	British Reinforcement Company
BS	British Standard
CCTV	Closed-Circuit Television
CI	Cast Iron
CO <sub>2</sub>	Carbon dioxide
DMA/DMZ	District Metering Area / District Metering Zone
DI	Ductile Iron
EC	Electrolytic Chlorination
H <sub>2</sub> S	Hydrogen Sulfide
HDPE	High Density Polyethylene Pipe
ICT	Information and Communications Technology
IEC	International Electrotechnical Commission
IEEE	Institute of Electrical and Electronics Engineers
JBALB	Rural Water Supply Department ( <i>Jabatan Bekalan Air Luar Bandar</i> )
FIFO	First-in-First-Out
FRP	Fiberglass Reinforced Plastic
GI	Galvanized Iron
HLT	High Level Tank
HT	High Tension
kVA	Kilo-volt-amperes
kW	Kilowatt
LT	Low Tension
MCC	Motor Control Centre
MCMC	Malaysian Communications and Multimedia Commission
ML	Mega Liter
MLD	Mega Liter per Day
MoH	Ministry of Health
MSB	Main Switch Board
MSCL	Mild Steel Cement Lining
NB-IoT	Narrowband Internet of things
NDWQS	National Drinking Water Quality Standard
NPSH	Net Positive Suction Head
NREB	Natural Resources and Environment Board
NRW	Non Revenue Water
O <sub>2</sub>	Oxygen
OSHA	Occupational Safety and Health Act
PLC	Programmable Logic Controller
RC	Reinforced Concrete
RCPM	Remote Cathodic Protection Management
RF	Radio Frequency
Rpm	Rotational speed per minute
SCADA	Supervisory Control and Data Acquisition
SESCO/SEB	Sarawak Energy Berhad

SEMI	Voltage Sag Immunity Standards
SRB	Sarawak River Board
SWSS	Smart Water Supply System
uPVC	Unplasticized Polyvinyl Chloride
WTP	Water Treatment Plant

## Contents

1	WATER DEMAND AND CONSUMPTION	1
1.1	Scope of Work Supply	1
1.2	Per Capita Consumption	1
1.3	Demand Fluctuations Factors	1
1.4	Allowance in excess	1
1.5	Fire Fighting Demand	2
1.6	Design Period for Water Supply Components	2
1.7	Population and Water Demand Estimates	2
1.7.1	Population Projection	2
1.7.2	Water Demand Estimation and Projection	3
2	Pipeline	4
2.1	Types of Distribution Systems	4
2.2	Maximum system design working pressure (MSDWP)	4
2.3	Distribution and Reticulation Layout	5
2.4	Selection of Type of Pipe Material	5
2.5	Principal advantages and limitation of selected water supply pipe materials	6
2.6	Selection and Installation of Air Valve	7
3	Service Reservoir	9
3.1	Basic Components	9
3.2	Type of Reservoir	9
3.3	Design requirement for treated water reservoir	10
3.4	Installation of Altitude Valve	11
4	Raw Water Resource	12
4.1	Assessment of Raw Water Sources	12
4.1.1	Surface Water Source	12
4.1.2	Ground Water Source	12
4.2	Selection of Raw Water Intake Location	13
4.3	Raw Water Intake Structure	13
4.3.1	Pontoon Intake	14
4.3.2	Jetty Intake	14
5	Water Treatment Plant Process	15
5.1	Raw Water Quality	15
5.2	Treated Water Quality	16
5.3	Treatment Plant Location	19
5.3.1	Planning	19
5.3.2	Plant design	19
5.4	Environmental factors	20
5.5	Treatment Process	20
5.5.1	Typical Process of Treatment	21
5.5.2	Selection of Treatment Process	21

5.6	Pre-Sedimentation	22
5.7	Chemical Dosing System	23
5.8	Chemical Storage	24
5.9	Filtration	25
5.10	Operation and Maintenance Requirement	25
5.11	Layout	25
5.12	Operation Building	27
5.12.1	The Laboratory	27
5.12.2	Filter Operating Gallery	28
6	Quarters	30
7	Sludge and Wastewater Disposal	31
8	Mechanical Works	32
8.1	Parameters for Pumps Selection	32
8.1.1	Raw water pump head design	34
8.1.2	Treated Water Pump Selection	34
8.2	Pump Installation Layout	34
8.3	Mechanical Seal vs Gland Packings (Surface Pump)	35
8.4	Motor Starter Requirement	35
8.5	Variable Speed Drive (VSD)	35
8.6	Surge Suppression System	36
8.7	Cranes	37
8.8	Forklift	38
8.9	Fire Fighting Services	38
8.10	Cathodic Protection	38
8.11	Pressure Gauge	38
9	Electrical Works	39
9.1	Power Supply	39
9.2	Sizing of Motor	39
9.3	Control Panel	39
9.4	Generator	39
9.5	General Lighting and Power	41
9.6	Earthing system	41
9.7	Lightning Protection System (LPS)	41
9.8	Main Switch Board	42
9.9	Electrical Wiring	42
10	Digitalization	43
10.1	Production Digitalization	45
10.2	Distribution Digitalization	55
10.3	Consumption Digitalization	58
10.4	System Integration	61
10.5	Last Mile Internet Connection (LMIC)	63
11	Safety and Security	64

11.1 Security Fencing and Gates	64
11.2 Other Security Consideration	64
11.3 Safety Requirement	64
12 Testing and Commissioning for Water Treatment Plant / Booster Pump Station	68
13 Color Code	68
14 Reference	69
15 Attachment	71
15.1 Checklist on design report for Watermain, Booster Station and Reservoir	71
15.2 Check list on tender drawing for Watermain, Booster Station and Reservoir	71
15.3 Checklist on design report for Water Treatment Facilities	71
15.4 Testing and Commissioning Document for Booster Station	71
15.5 Testing and Commissioning Document for Water Treatment Plant	71

## 1 WATER DEMAND AND CONSUMPTION

### 1.1 Scope of Work Supply

Public potable water supply systems in JBALB Sarawak jurisdiction.

### 1.2 Per Capita Consumption

Category		Consumption
Domestic	Urban	250 litres/capita/day
	Rural	180 litres/capita/day
Commercial	Hotels/resorts	450 litres/room/day
	Complexes/Office buildings	10 litres/m <sup>2</sup> /day
	Shop houses	2000 litres/floor/day
Institutions	Schools (day)	45 litres/pupil/session/day
	Schools (Boarding)	250 litres/pupil/session/day
	Hospitals	400 litres/bed/day
	Government clinics	45 litres/patient/day
	Armed Forces/Polices	350 litres/person/day
	Places of worship	10 litres/person/day
Industrial*	Light	22,000 litres/hectare/day
	Medium	35,000 litres/hectare/day
	Heavy	45,000 litres/hectare/day

Note: -

\* As classified under the *Piawaiian Perancangan Kawasan Perindustrian* issued by the *Jabatan Perancangan Bandar dan Desa* or Land & Survey Department Sarawak.

- Urban means communities with population exceeding 10,000 persons for design purpose.

### 1.3 Demand Fluctuations Factors

Peak demand is obtained by multiplying the average demand by the peak factor in the design of pipelines:

Maximum hourly or peak consumption	2.2
Average daily consumption	1.0

### 1.4 Allowance in excess

Allowance in excess of the consumption demand based on average daily consumption should be made to provide for the following: -

- a. 20% reserve margin for treatment plant usage
- b. 25% for non-revenue water (distribution loss)

Note: -

For design with the existing supply, it is required to study the actual demand pattern and subsequently derive the appropriate factors and figures for non-revenue water.

## 1.5 Fire Fighting Demand

Risk Category	Average Total Flow (Litres Per Minute)	Spanning (Metres)	Maximum No. Of hydrant Outlets Used Simultaneously
<u>Class A Risk</u> Large buildings, shopping complexes, high rise buildings, large industrial estate, Warehouse and ports	4100	90	3@ 1370 litre per minute
<u>Class B Risk</u> Congested areas with buildings up to 5 storeys	2700	90	2@ 1370 litre per minute
<u>Class C Risk</u> Shophouse up to 3 storeys, light industry	1370	90	1
<u>Class D Risk</u> Residential terrace house, detached, semi detached	1140	120-terrace 150-detached/ semi - detached	1
<u>Class E Risk</u> Others	680	180	1

Note: -

1. To comply with the Fire and Rescue Department of Malaysia requirement.
2. For Fire flow plus peak demand, the minimum residual pressure should be **10m** head.
3. The system should be designed to provide minimum residual pressure at **20m** head for urban and **10m** head for rural during the peak demand at end of the pipeline.

## 1.6 Design Period for Water Supply Components

Demand projection provided based on 5 yearly intervals up to maximum design period.

- Civil works and Reticulation work - maximum of 30 years.
- Pumps, mechanical, electrical and electronic items - minimum of 5 years.

## 1.7 Population and Water Demand Estimates

The predicted population growth should be based on the latest figures from the Department of Statistics Malaysia which should be projected using appropriate growth rate and/or from other sources, e.g. District Health Office, District Office & Education Department. Population density figures and predicted density changes should be derived and used.

### 1.7.1 Population Projection

The basic formula for population projection for water supply planning purposes: -

$$P_n = P(1 + r)^n$$

Where	$P_n$	=	Projected population
	$P$	=	Population at census
	$r$	=	Annual growth rate
	$n$	=	Number of years

### **1.7.2 Water Demand Estimation and Projection**

The basic formula for water demand estimation to be used is as follows: -

$$\mathbf{Wd_n} = (\mathbf{P_n \times C \times DF}) + \mathbf{D_n}$$

Where,

$Wd_n$  = Water demand at the end of year “n”

$P_n$  = Projected population at the end of year “n”

$C$  = Per capita consumption

$DF$  = Demand fluctuation factor

$D_n$  = Additional demand for new developments and Allowance  
in excess of the consumption at the end of year “n”

$n$  = Number of years

Water Demand estimation and projection provided based on 5 yearly intervals up to maximum design period.

## 2 Pipeline

The water distribution system consists of transmission, distribution and reticulation pipelines, balancing and service reservoirs and treated water pumping stations. The objective of a water transmissions and distribution system is to convey water at a suitable pressure and the required quantity to the consumers.

Definitions are as follows:

1. Transmission pipelines – gravity or pumping mains that carry water from WTP/pumping stations to reservoirs or reservoirs to reservoirs.
2. Distribution pipelines – gravity mains that connect water from service reservoirs to reticulation mains.
3. Reticulation pipelines – pipes of smaller sizes that carry water from distribution pipes to water demand centres such as housing areas or factories.
4. Balancing / Service reservoirs – storage tanks that hold water for certain period of time.
5. Treated water pumping stations – pumping facilities that pump water to a higher elevation such as reservoirs.

### 2.1 Types of Distribution Systems

System	Advantages	Disadvantages
Gravity	<ul style="list-style-type: none"> <li>• Most reliable</li> <li>• Low operational costs</li> </ul>	<ul style="list-style-type: none"> <li>• Higher capital cost for construction of elevated water tanks</li> <li>• No regulation of flow and pressure</li> </ul>
Pumping and gravity combination	<ul style="list-style-type: none"> <li>• Least cost option under certain topographical conditions</li> </ul>	<ul style="list-style-type: none"> <li>• Problems associated with operation and maintenance of pumping systems</li> </ul>
Direct pumping	<ul style="list-style-type: none"> <li>• Pressure and flow can be easily regulated</li> <li>• Remedial action can be speedily taken</li> </ul>	<ul style="list-style-type: none"> <li>• Too dependent on power supply</li> </ul>

### 2.2 Maximum system design working pressure (MSDWP)

1. For a pumping system, the MSDWP is the maximum pumping pressure under the closed valve condition during the design period of the system. This valve shall be located at the end of the pipeline of the pumping system.
2. For a gravity system, the MSDWP is the maximum pressure that the system will be subjected to when the service reservoir is full during the design period of the system.
3. For a combined system comprising of a pumping system and a gravity system, the section tests and system test for each system shall be carried out separately.

### 2.3 Distribution and Reticulation Layout

1. The service reservoir shall be as close as possible to the water demand area, so as to provide the least capital and operating costs.
2. Where the service reservoir cannot be sited close to demand area, a **twin pipeline** layout shall be considered.
3. The reticulation pipes shall be laid so as to form a loop system and dead ends shall be discouraged.
4. Where extreme topographical conditions prevail in demand areas, such as greater than 40 meter difference in elevation, pressure zoning of service according to ground elevations may be necessary. This can be achieved by using pressure reducing valve.
5. Pipelines shall be preferably be laid adjacent to roads so as to provide easy access for maintenance. Wayleave approval must be applied to relevant authorities / parties before proceeding with the works.
6. The system should be designed to provide **minimum residual pressure at 10m** head for rural during the peak demand at end of the pipeline.
7. In all reticulation pipes, the maximum residual pressure in the system shall not exceed **60m head** as far as possible. Where necessary, pressure reducing valves should be installed to reduce NRW. Booster station in sequence or in-line BPS may be considered.
8. Watermains should be usually laid in front of shoplots and houses.
9. Gate/sluice valves should be located to minimize water supply interruption during pipe breakages. The valves interval should be **at least 1.5km internal** or at every tee-off junction.
10. Valves should not be located under pavements whenever possible.
11. Position of fire hydrants to be approved by the Fire and Rescue Department of Malaysia.
12. All the pipes, fittings, valves, specials shall conform with the latest approval from the State Water Authority.
13. Pumping mains should preferably be of ductile iron or steel pipes unless otherwise approved.

### 2.4 Selection of Type of Pipe Material

The followings considerations shall apply for the selection of type of pipe material for water supply: -

1. Size and maximum working and test pressure, including surge pressure.
2. Strength of pipe to withstand designed internal and external loads.
3. Durability of pipe.
4. Suitability and workability for laying and operating requirements.
5. Capital, operation and maintenance cost.
6. Extent of possible leakage.
7. Pipe material availability
8. Evaluation against environmental factors.
9. Evaluation against conveyed water quality.
10. Evaluation against soil/groundwater properties and characteristics.

## 2.5 Principal advantages and limitation of selected water supply pipe materials

Pipe Material	Advantages	Disadvantages
Ductile Iron (DI)	<ul style="list-style-type: none"> <li>▪ High mechanical strength and toughness</li> <li>▪ High fatigue resistance</li> <li>▪ Ease of jointing</li> <li>▪ Flexible joint tolerates some deflection</li> <li>▪ Pipe impermeable to gas and organic contaminants</li> <li>▪ Easy to trace for detection and location of leaks</li> <li>▪ Well established methods of repair</li> </ul>	<ul style="list-style-type: none"> <li>▪ Heavy</li> <li>▪ Susceptible to corrosion if internal or external protection systems damaged</li> <li>▪ Potential high pH problems when conveying soft waters</li> <li>▪ Retrospective installation of fittings may be complicated on ungauged pipes (dia &gt; 350mm)</li> </ul>
High Density Polyethylene (HDPE)	<ul style="list-style-type: none"> <li>▪ Corrosion resistant</li> <li>▪ Relatively light-weight</li> <li>▪ Flexible</li> <li>▪ Out-of-trench jointing possible</li> </ul>	<ul style="list-style-type: none"> <li>▪ Fusion jointing requires skilled installers and special equipment</li> <li>▪ Reliant on stable support from soil</li> <li>▪ Susceptible to permeation or degradation on prolonged exposure to direct sunlight</li> <li>▪ Pipe location difficult making leakage detection complicated</li> <li>▪ Retrospective installation of fittings or repair complicated in large diameters (nominal size &gt; 335mm)</li> </ul>
Steel	<ul style="list-style-type: none"> <li>▪ High mechanical strength and toughness</li> <li>▪ High fatigue resistance</li> <li>▪ Flexible</li> <li>▪ Available in long lengths</li> <li>▪ Can be welded to form a leak-free system that will resist end load</li> <li>▪ Easy to trace</li> <li>▪ Pipe impermeable to gas and organic contaminants</li> <li>▪ Easy for detection and location of leaks</li> </ul>	<ul style="list-style-type: none"> <li>▪ Welded joints require skilled installers and special equipment</li> <li>▪ Susceptible to corrosion if protection systems damaged</li> <li>▪ Welded joints normally required reinstatement of protection systems on site</li> <li>▪ Cathodic protection requires regular monitoring or maintenance</li> <li>▪ Potential high pH problems when conveying soft waters</li> <li>▪ Reliant on stable support from soil</li> <li>▪ Retrospective installations of fittings or repair may be problematical if non-standard pipe size are used</li> </ul>
Unplasticized Polyvinyl Chloride (uPVC)	<ul style="list-style-type: none"> <li>▪ Corrosion resistant</li> <li>▪ Relative light-weight</li> <li>▪ Ease of jointing</li> </ul>	<ul style="list-style-type: none"> <li>▪ Susceptible to impact damage</li> <li>▪ Susceptible to poor installation</li> <li>▪ Reliant on stable support from soil</li> <li>▪ Ultraviolet degradation on prolonged exposure to direct sunlight</li> </ul>

Pipe Material	Advantages	Disadvantages
		<ul style="list-style-type: none"> <li>Susceptible to permeation or degradation by certain organic contamination</li> <li>Pipe location difficult making leakage detection complicated</li> </ul>
Acrylonitrile Butadiene Styrene (ABS)	<ul style="list-style-type: none"> <li>Corrosion resistant</li> <li>Relative light-weight</li> <li>Ease of jointing</li> </ul>	<ul style="list-style-type: none"> <li>Susceptible to impact damage</li> <li>Susceptible to poor installation</li> <li>Reliant on stable support from soil</li> <li>Ultraviolet degradation on prolonged exposure to direct sunlight</li> <li>Susceptible to permeation or degradation by certain organic contamination</li> <li>Pipe location difficult making leakage detection complicated</li> </ul>

Pipe Material Usage	DI	Steel	HDPE	uPVC	ABS
With pumping stations, WTP, reservoir sites	**	**	√	X	X
Built into water retaining structures	**	X	X	X	X
Under crossing, road crossing	**	**	√	X	√
Over crossing, overhead bridge, culvert crossing	√	**	X	X	X
Transmission pipe lines	√	**	√	X	X
Distribution pipelines	√	√	**	√	√
Reticulation pipelines	√	√	**	**	**
Submarine pipelines	X	√	**	X	X
Corrosive environment, coastal areas	√	X	**	√	**
Peat soil	√*	√*	X	X	X
Swamp	√*	√*	√	√	√
Contaminated soil (petroleum & acid based)	√	√	X	X	X
Nominal diameter 150mm – 500mm	**	**	**	**	**
Nominal diameter above 500mm	√	**	X	X	X

Legend:

**	Highly recommended
√	Recommended
X	Not recommended
√*	For steel, cathodic protection may required. For DI, polyethylene sleeve is required.

## 2.6 Selection and Installation of Air Valve

Excess air in a pipe can cause slower flow, pipe churning damage, cause turbulence, and increased corrosion rate.

Air valves allow excess air to escape from the pipeline while containing pipeline fluids within the pipeline during operation. They also allow air to escape from the pipes during filling.

The valves can inject air into the pipes while they are being emptied, preventing a vacuum, which would cause the pipe to collapse.

Kinetic type air valve so named combination air valves, triple acting air valves etc. The kinetic air valve provides excellent protection against vacuum formation with its advanced aerodynamics design and kinetic orifice. The design of air valve shall enable the following functions: -

- Large air release during water filling pipeline;
  - Small air release under pressurized pipeline;
  - Large air intake during draining or burst of the pipeline.
- i. The valve shall be of float type, either single or double chamber, having a cast iron / ductile iron full bore body and bolted cover, designed with bottom inlet, float guide mechanism and the cylindrical float. The float and all parts of the valve and operating mechanism shall be made of non-corrodible materials. The float shall be of the type of cylindrical shape, made of solid material, preferably stainless-steel float or hard plastic-based material to avoid deformation and ensure smooth sliding movement.
  - ii. The valve shall be able to sustain high water hammer (or anti water hammer) and allow quick closure without failure.
  - iii. The air valve shall have no arm or no lever to prevent vibrating, bending, direct closure of the float.
  - iv. The valve cover shall be able to prevent the entrance of insects and foreign particles.
  - v. The maintenance of the valve shall be performed from the top without the need to remove the valve from the pipe.
  - vi. The valve shall be fusion epoxy coated inside and outside of valve body for long term services.

**The Installation of Air Valve**

Air valves shall be provided at all peak points along a pipeline profile and where there are significant negative changes in pipeline gradient.



### 3 Service Reservoir

- To provide a reserve of water due to breakdown
- To provide a reserve to meet fluctuating demand
- To act as a break pressure tank
- To provide a reserve of water for fire fighting

#### 3.1 Basic Components

- a. Inlet pipe for the entry of water
- b. Outlet pipe connected to the distribution mains
- c. Overflow pipe discharging into drain and maintaining level
- d. An indicator for indicating the depth of water which can be read from outside or SCADA system
- e. Scour pipe for cleaning the reservoir
- f. Automatic devices or altitude valve to stop pumping when the tank is full.

#### 3.2 Type of Reservoir

RC Elevated Reservoirs



Pressed Steel Tank



FRP Elevated Tank



HDPE Elevated Tank



Bolted Steel Tank



Other Types of Tank



### 3.3 Design requirement for treated water reservoir

- a. All reservoirs should be designed so as to be fully protected from all possible contamination without internal tank liner.
- b. All elevated storage tank and tower should be of Reinforced Concrete unless otherwise approved.
- c. Reservoir with capacity **more than 1 ML** should have partition for maintenance and cleaning of the interior and shall not allow stratification of water quality. Standby outlet pipe shall be allowed.
- d. All storage reservoirs are to be provided with scour pipe of sufficient size that bigger than inlet pipe.
- e. The minimum storage requirement for service reservoirs and suction tanks should be designed to allow for **one (1) day** storage and meet fluctuating demand and firefighting requirement.
- f. The treated water suction tank should have a minimum capacity equivalent to **eight (8) hours pumping rate**.

- g. All appurtenances and regulating services should be standard water supply practices. These include pressure regulating valves, flow measurement recorders, air and reflux valves, altitudes valves, level indicator etc.
- h. Preferable inlet pipe is located at top of the tank and outlet pipe at bottom of the tank.
- i. Bypass system between inlet and outlet shall be provided.
- j. Proper safety access and staircase from the ground level to tank shall be provided.

### 3.4 Installation of Altitude Valve

The altitude valves (AV) are used to control the level of water in elevated reservoirs. They may also be installed at ground reservoir inlet pipes greater than 450mm diameter. Altitude valves shall be installed in chambers **above ground** and shall be provided with bypass pipe arrangement so that distribution to the supply of water is minimized when the valve is being maintained.

- Pilot is installed at higher ground to prevent flooding so that it can "breathe" normally and the whole AV will function normally.
- Pilot of the AV is connected with 3 lines:-
  - a) Copper lines for pressure adjustment.
  - b) HDPE line - pressure sensing line, connection from HLT / Reservoir to pilot.
- Technically, pilot of the AV is having similar design as the AV body, equipped with the small diaphragm, and magnify the pressure difference to AV body to open or close the diaphragm. It shall be operational normally under atmosphere pressure. When pilot is submerged in the water, it's lost its sensitivity and always result overflow of the HLT.

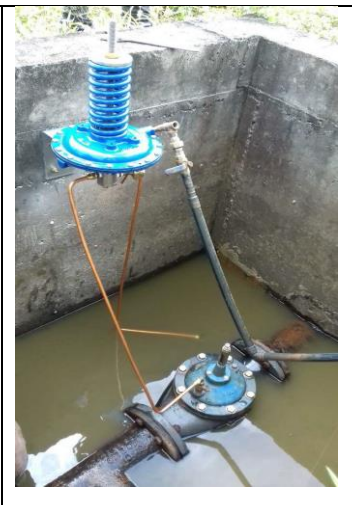

## 4 Raw Water Resource

### 4.1 Assessment of Raw Water Sources

The assessment of raw water sources should include the following: -

- a) River Yield - safe yield based 7-day low flow for a return period of 50 years vs. estimated future demand.
- b) Raw water quality – present & future status with emphasis on existing and potential contamination/pollution by chemical and bacteriological agents.
- c) Land use and heavy impact activities surrounding raw water source.
- d) Requirements for storage - location, volume, capacity of catchment areas & yields, duration of drought & water quality due to storage and fluctuation. The capacity of the storage will be determined by duration of drought.
- e) Source protection & alarming system & raw water (quality & quantity) monitoring system.
- f) Catchment details and special requirement for catchment control measures.
- g) Various possible options of water sources (surface water/groundwater)
- h) Environmental flow & other legal users of the source
- i) Cost/Benefit analysis

#### 4.1.1 Surface Water Source

- a) Various possible options for the surface water source have been consider.
- b) Comparison of the various options for the raw water source has been carried out (should include costs advantages & disadvantages, etc.)
- c) The safe yield of the recommended raw water source satisfied the following conditions:
  - ❖ Adequate to meet the maximum projected water demand while not significantly affecting the ecology of the water course downstream of the intake.
  - ❖ Provide a reasonable surplus for anticipated growth.
  - ❖ Adequate to compensate for all losses such as sitting, evaporation, seepage, etc.
  - ❖ Adequate to provide ample water for other legal users of the source.
- d) Where run of river safe yield is insufficient, adequate impounded storage for raw water is provided.

#### 4.1.2 Ground Water Source

The following information on the proposed ground water source have been provided:

- a) Sites considered and reasons for selection.
- b) Elevations with respect to surrounding and flood plain(s).
- c) Character of formations through which the source is to be developed.
- d) Geologic conditions affecting the site such as test holes, abandoned wells or anticipated interference between proposed and existing wells.
- e) Summary of source exploration (test well depths, location, pumping rates and duration, water levels, specific yield, capture area and pumping radius of influence for production wells, etc.
- f) Raw water quality report

- g) Sources of possible contamination such as sewers and sewerage facilities, highways, landfills, chemical facilities, etc.
- h) Preserve of existing wells and their effects on proposed wells.
- i) Depths of any known water bearing aquifers that will reduce well yield if penetrated.
- j) Total depths of all known water bearing aquifers in the area concerned.
- k) Wellhead protection measures considered.
- l) Aquifer protection and management issues.

## 4.2 Selection of Raw Water Intake Location

The design should take into consideration, the selection of site of Intake based on:

- a) Raw water quality & quantity & environmental considerations (geological, biological, floodplain, debris/logs issue, riverbank conditions, erosion and deposition, seismic/wave, safety, river navigation, etc.);
- b) Silt loading, debris/log, provision for desilting, screening and isolation of intake, facility and protection against damage, flow distribution, ease of operation and maintenance;

## 4.3 Raw Water Intake Structure

- (a) The design should take into consideration riverbank conditions, soil investigation, maximum & minimum water levels, presence of erosion and deposition, silt loading, debris, provision for desilting, screening & isolation of intake, dual facility & protection against damage.
- (b) All intake structures to be on stable ground and stable stretches of the rivers.
- (c) The design shall have sufficient factor of safety against external forces such as strong currents, floating and submerged materials, etc.
- (d) Site shall be of easy access and have proper access (asphaltic concrete tar sealed road).
- (e) Intake structure is located at sufficient water depth so as to be able to keep the raw water pumps low flow.
- (f) Intake structure does not obstruct passage of vessels in navigable rivers. Warning signages and lightings as per requirement by SRB are to be provided.
- (g) Is designed to supply evenly distributed flow to the pump suction to prevent formation of surface/submerged vortices, introduction of air into the pump, etc.
- (h) Is designed to cater for future upgrading or addition of pumps to cater for increase in water demand.
- (i) Intake structure is designed to allow the pumps to achieve optimum hydraulic performance for all operating conditions.
- (j) Is equipped with a coarse screen and a fine screen, both removable and are readily accessible for cleaning (preferably self-cleaning).
- (k) Fenders/log booms are provided to protect the intake from floating logs, debris, etc.
- (l) Lifting hoist is provided for installation and maintenance of the pumps, pipes, fittings, valves, etc. 'A' frame can be used only if submersible pump is less than 0.5 tonne otherwise monorail/gantry cranes have to be provided.
- (m) Waterproof shed is provided for switchgear, lifting hoist & other electrical equipment. Switchgear & terminal box are cited above highest flood level possible.
- (n) Provisions of instruments for measuring water levels (e.g., ultrasonic level sensor) and quantities and for monitoring water quality are required.

- (o) Protection from the entry of stray animals and trespassers by the provision of fencing and lighting.
- (p) Provision of oil boom kit or other products to contain oil spillage or contamination at raw water intake.

#### **4.3.1 Pontoon Intake**

- (a) Pontoon structure is properly designed using durable material.
- (b) The pumpsets can be securely mounted on the pontoon.
- (c) The pontoon is securely anchored without risk of overturning during changes in water level'
- (d) Where mooring ropes are used, they are long enough and well secured to allow for changes in water level.
- (e) The pump's discharge pipe is long enough and well secured to allow for changes in water level.
- (f) Heavy duty flexible discharge pipe of suitable material is used.
- (g) A housing is provided over the pump(s) and motors where centrifugal pumps are used.\
- (h) Coarse screens are incorporated in the design of the pontoon to protect the pumps or footvalves from debris, etc.
- (i) Electrical cables of sufficient length are designed to allow for highest water level pontoon position.
- (j) Pontoon structure is properly linked with jetty accessible for operation & maintenance, including hand operated cart.

#### **4.3.2 Jetty Intake**

- (a) The jetty is designed to meet the requirements of the appropriate design codes and standards, to sound engineering principles and is fit for the intended purposes.
- (b) The intake jetty is sited on stable ground which is not subjected to siltation and erosion.
- (c) The jetty is of reinforced concrete construction.
- (d) The deck of the jetty is above the maximum water level.
- (e) The jetty is designed with platform for inspection, mounting & dismantling of raw water pumps, valves, etc.
- (f) Rigid pump base should be provided for installation of pumps.
- (g) Pump base should be sited at minimum low water level.
- (h) The jetty width is designed for vehicle access for transporting pumps, valves, pipes, etc., during maintenance.

## 5 Water Treatment Plant Process

Purpose of water treatment:

- To remove colour, dissolved gases and turbidity
- To remove taste and odour
- To remove disease causing microorganisms so that the water is safe to drink.
- To remove hardness of water (for industrial use)

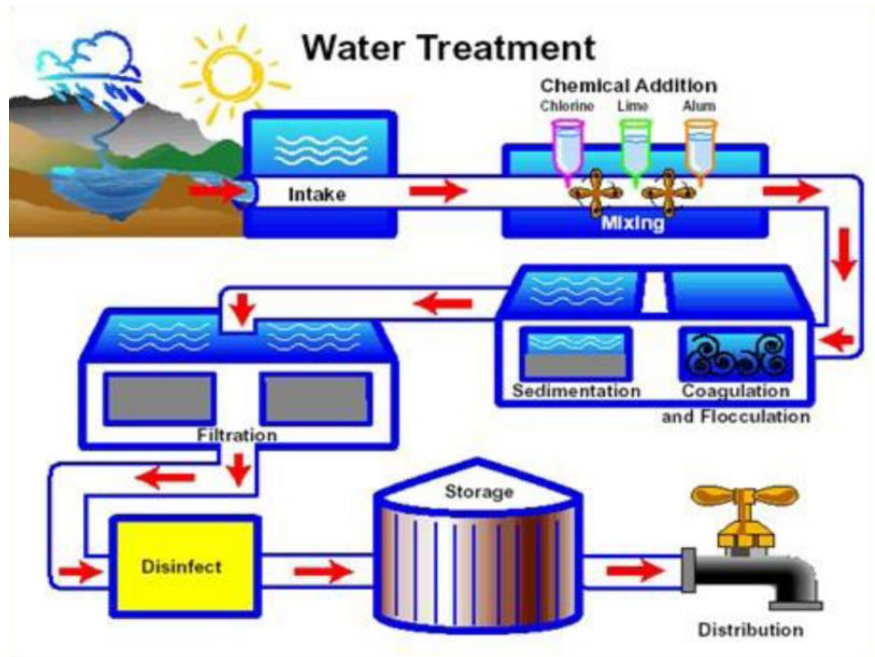

### 5.1 Raw Water Quality

The physico-chemical and bacteriological characteristics and constituents in the raw water shall comply fully with the latest National Drinking Water Quality Standards (Table 1, Column I, NDWQS). It lists the recommended physical, chemical, radiochemical and microbiological levels of raw water which is suitable for conventional treatment as a potable water supply.

**Table 1, Column I, National Drinking Water Quality Standards, Ministry of Health Malaysia**

RECOMMENDED RAW WATER QUALITY		
No	Parameters	Column I
		Acceptable Value
		mg/l (unless otherwise stated)
<b>GROUP I</b>		
1	TOTAL COLIFORM	5,000 MPN/100ml or cfu/100ml
2	TURBIDITY	
3	COLOUR	
4	pH	
<b>GROUP II</b>		
1	TOTAL DISSOLVED SOLIDS	1500
2	BIOLOGICAL OXYGEN DEMAND	6
3	CHEMICAL OXYGEN DEMAND	10
4	CHLORIDE	250
5	ANIONIC DETERGENT MBAS	1.0
6	AMMONIA (as N)	1.5
7	NITRATE (as N)	10
8	IRON (as Fe)	1.0
9	FLUORIDE	1.5

10	HARDNESS	500
11	MANGANESE	0.2
	<b>GROUP III</b>	
1	MERCURY	0.001
2	CADMIUM	0.003
3	SELENIUM	0.01
4	ARSENIC	0.01
5	CYANIDE	0.07
6	LEAD	0.05
7	CHROMIUM	0.05
8	SILVER	0.05
9	COPPER	1.0
10	MAGNESIUM	150
11	SODIUM	200
12	ZINC	3
13	SULPHATE	250
14	MINERAL OIL	0.3
15	PHENOL	0.002
	<b>GROUP IV</b>	
	<u>ORGANOCHLORINE PESTICIDES:</u>	
1	ALDRIN/DIELDRIN	0.00003
2	DDT	0.002
3	HEPTACHLOR & HEPTACHLOR EPOXIDE	0.00003
4	METHOXYCHLOR	0.02
	<u>NON-ORGANOCHLORINE PESTICIDES:</u>	
5	HEXACHLOROBENZENE	0.001
6	LINDANE	0.002
7	CHLORDANE	0.0002
	<u>HEBRICINES:</u>	
8	2,4-D (DICHLOROPHENOXYACETIC ACID)	0.03
	<b>GROUP V</b>	
	<u>RADIOACTIVITY:</u>	
1	GROSS $\alpha$	0.1Bq/l
2	GROSS $\beta$	1.0Bq/l
<b>TOTAL</b>	<b>40 PARAMETERS</b>	

## 5.2 Treated Water Quality

The physico-chemical and bacteriological characteristics and constituents in the treated water shall comply fully with the latest National Drinking Water Quality Standards (Table 2, Column I, NDWQS). It lists the recommended physical, chemical, radiochemical and microbiological levels of treated water which is suitable after undergoing conventional treatment for potable water supply and shall not be exceeded for maximum protection of the consumer.

**Table 2, Column 1, National Drinking Water Quality Standards, Ministry of Health Malaysia**

DRINKING WATER QUALITY STANDARDS		
No	Parameters	Column I
		Maximum Acceptable Value
		mg/l (unless otherwise stated)
	<b>GROUP I</b>	
	<b>MICROBIOLOGICAL:</b>	
1	TOTAL COLIFORM	MPN METHOD/ MEMBRANE FILTRATION METHOD: MUST NOT BE DETECTED IN ANY 100ml SAMPLE
2	E.coli OR THERMOTOLERANT	ABSENT IN 100ml SAMPLE
3	COLIFORM BACTERIA	
4	FAECAL STREPTOCOCCI	MEMBRANCE FILTER METHOD: ABSENT IN 100ml SAMPLE

5	CLOSTRIDIUM PERFRINGENS	MON METHOD: <1 IN 100ml SAMPLE
6	VIRUSES	ABSENT
7	PROTOZOA	ABSENT IN 100ml
8	HELMINTHS	ABSENT IN 100ml
9	<b>PHYSICAL:</b>	
10	TURBIDITY	5 NTU
11	COLOUR	15 TCU
12	pH	6.5 – 9.0
13	FREE RESIDUAL CHLORINE	0.2 – 5.0
14	COMBINED RESIDUAL CHLORINE	NOT LESS THAN 1.0
14	MONOCHLORAMINE	3
	<b>GROUP II</b>	
	<b>INORGANIC:</b>	
1	TOTAL DISSOLVED SOLIDS	1000
2	CHLORIDE	250
3	AMMONIA (as N)	1.5
4	NITRATE (as N)	10
5	IRON (as Fe)	0.3
6	FLUORIDE	0.4 – 0.6
7	HARDNESS	500
8	ALUMINIUM	0.2
9	MANGANESE	0.1
	<b>GROUP III</b>	
1	MERCURY	0.001
2	CADMIUM	0.003
3	ARSENIC	0.01
4	CYANIDE	0.07
5	LEAD	0.01
6	CHROMIUM	0.05
7	COPPER	1
8	ZINC	3
9	SODIUM	200
10	SULPHATE	250
	<b>TRIHALOMETHANE:</b>	
	The sum of the ratio of the concentration to each of the guideline value should not exceed 1.	
11	CHLOROFORM	0.2
12	BROMOFORM	0.1
13	DIBROMOCHLOROMETHANE	0.1
14	BROMODICHLOROMETHANE	0.06
15	SELENIUM	0.01
16	SILVER	0.05
17	MAGNESIUM	150
18	ANTIMONY	0.005
19	BARIUM	0.7
20	BORON	0.5
21	MOLYBDENUM	0.07
22	NICKEL	0.02
23	URANIUM	0.002
24	HYDROGEN SULFIDE	0.05
25	MINERAL OIL	0.3
26	PHENOL	0.002
27	BROMATE	0.025
28	CHLORITE	0.2
29	2-CHLOROPHENOL	0.0001
30	2,4-DICHLOROPHENOL	0.0003
31	2,4,6-TRICHLOROPHENOL	0.2
32	FORMALDEHYDE	0.9
33	DICHLOROACETIC ACID	0.05
34	TRICHLOROACETIC ACID	0.1
35	CHLORAL HYDRATE (TRICHLOROACETALDEHYDE)	0.01
36	DICHLOROACETO-NITRILE	0.09

37	DIBROMOACETO-NITRILE	0.1
38	TRICHLOROACETO-NITRILE	0.001
39	CYANOGEN CHLORIDE (as CN)	0.07
	<b>GROUP IV</b>	
1	ALDRIN/DIELDRIN	0.00003
2	DDT	0.002
3	HEPTACHLOR & HEPTACHLOR EPOXIDE	0.00003
4	METHOXYCHLOR	0.02
5	LINDANE (BHC)	0.002
6	ENDOSULFAN	0.03
7	CHLORDANE	0.0002
8	1,2-DICHLOROPROPANE	0.04
9	1,3-DICHLOROPROPENE	0.02
10	HEXACHLOROBENZENE	0.001
11	PENTACHLOROPHENOL	0.009
12	ALACHLOR	0.02
13	ALDICARB	0.01
14	AMETRYN	0.05
15	ATRAZINE	0.002
16	BENTAZONE	0.3
17	CARBOFURAN	0.007
18	CHLOROTOLURON	0.03
19	CYANAZINE	0.0006
20	2,4-DICHLOROPHENOXYACETIC ACID (2,4D)	0.03
21	DIQUAT	0.01
22	1,2-DIBROMO-3-CHLOROPROPANE	0.001
23	1,2-DIBROMOETHANE	0.0004
24	ISOPROTURON	0.009
25	MCPA	0.002
26	METOLACHLOR	0.01
27	MOLINATE	0.006
28	PENDIMETHALIN	0.02
29	PERMETHRIN	0.02
30	PROPANIL	0.02
31	PYRIDATE	0.1
32	SIMAZINE	0.002
33	TRIFURALIN	0.02
34	2,4 DB	0.09
35	DICHLORPROP	0.1
36	FENOPROP	0.009
37	MECOPROP	0.01
38	2,4,5-T	0.009
39	TERBUTHYLAZINE	0.007
	<b>ORGRANIC SUBSTANCES:</b>	
40	CARBON TETRACHLORIDE	0.002
41	DICHLOROMETHANE	0.02
42	1,2-DICHLOROETHANE	0.03
43	1,1,1-TRICHLOROETHANE	2
44	VINYL CHLORIDE	0.005
45	1,1-DICHLOROETHENE	0.03
46	1,2-DICHLOROETHENE	0.05
47	TRICHLOROETHENE	0.07
48	TETRACHLOROETHENE	0.04
49	BENZENE	0.01
50	TOULENE	0.7
51	XYLENE	0.5
52	ETYL BENZENE	0.3
53	STYRENE	0.02
54	BENZO (A) PYRENE	0.0007
55	MONOCHLOROBENZENE	0.3
56	1,2-DICHLOROBENZENE	1
57	1,4-DICHLOROBENZENE	0.3
58	TRICHLOROBENZENE (TOTAL)	0.02

59	DI (2-ETHYLHEXYL) ADIPATE	0.08
60	DI (2-ETHYLHEXYL) PHTHALATE	0.008
61	EDETIC ACID (EDTA)	0.6
62	ACRYLAMIDE	0.0005
63	EPICHLOROHYDRIN	0.0004
64	HEXACHLOROBUTADIENE	0.0006
65	MICROCYSTIN-LR	0.001
66	NITRILOTRIACETIC ACID (NTA)	0.2
67	TRIBUTYLIN OXIDE	0.002
	<b>GROUP V</b>	
	<b>RADIOACTIVITY:</b>	
1	GROSS $\alpha$	0.1Bq/l
2	GROSS $\beta$	1.0Bq/l
<b>TOTAL</b>	<b>131 PARAMETERS</b>	

Notes: Any toxic substances not listed shall be deemed as not allowable in drinking water

### 5.3 Treatment Plant Location

Principal factors to be considered when selecting a WTP site: -

#### 5.3.1 Planning

- Present and future demands, direction and rate of growth of service area and potential deterioration of source quality in future so that the site selected is flexible enough to accommodate these changing factors.
- Plant site can be designed to be compatible with its surroundings which normally involve studying the master plan for area concerned (if available) and discussions with local authorities and principal groups who may be affected.

#### 5.3.2 Plant design

- Various space needs of a plant and to carefully consider the construction, operation and environmental needs, initially and in the future (extensions of at least two more bays).
- Site topography, constraints imposed by existing facilities, environmental aspects, etc.

(a) **Relation to intake site and service area**

The site is optimally located in relation to the source of water and the area to be served. It shall be located at strategic location and preferably with easy access. Raw water intake shall be located as near as possible to the WTP.

(b) **Elevation and pumping**

Assessment towards the conservation of power costs having regards to the various variable on pump sizes, sizes of transmission lines, service area elevations including future service area limits to determine the optimum configuration.

(c) **Site topography**

Topography of site shall suit the hydraulic profile of the WTP process components and surface drainage. A gentle and moderate slope is required, and the process units shall be aligned down the slope rather than across, to achieve gravity flow through the plant to avoid excessive earthworks and the need for elevated structures.

(d) **Geotechnical**

Assessment and evaluation of potential sites by reference to geological map and also site inspection and reconnaissance, together with local knowledge of site conditions. In general, sites with high groundwater levels, swampy or with poor soil conditions, involve excessive rock excavation, cut and fill, extensive storm drainage facilities shall be avoided as this would involve extra costs for design and construction.

(e) **Flooding**

Shall always be sited above the 1 in 100-year design flood level or maximum flood levels experienced if records are insufficient for flood analysis.

(f) **Access**

Preferable to be (a) in proximity of existing main roads (to enable delivery of chemicals & equipment & facilitate construction) having no restriction on type of traffic and (b) Alignment and gradient of access road shall be so planned that trucks and tankers laden with chemical load can run on it without load shedding.

(g) **Power Supply and telecommunications**

Shall be located where power supply and telecommunication facilities are readily available. Backup on site diesel generator shall be provided to increase in reliability of power supply.

(h) **Land availability**

Shall has the least land acquisition problems and costs.

## 5.4 Environmental factors

An environmental study complying the Natural Resources & Environment Ordinance shall be carried out to assess the effects which the WTP may have on its surrounding areas or vice versa. Other factors such as noise and dust during construction, discharge of wastewater into surrounding areas (during T&C of plant including from pipelines and reservoirs), noise during operation (pumps, generators and chemical trucks), danger from chlorine leakages (both in plant and during delivery), dust and odours from chemicals, residuals, etc, residuals and wastewater disposal effect on water courses/lakes and overflow discharge and its effect on water courses.

## 5.5 Treatment Process

Main factors in selection of treatment process systems:

- Source water quality
- Treated water quality standard.
- Reliability of process systems and equipment
- Operational requirements and personnel capacities
- Flexibility in dealing with changing water quality and equipment malfunctions

- Available space for construction
- Plant residuals disposal constraints
- Capital and operating cost

### 5.5.1 Typical Process of Treatment

- (a) Raw water extraction – pump from rivers, streams, ponds, storage dams or underground wells.
- (b) Pre-sedimentation tank – as primary settling to remove small particulars such as sand and silt from the raw water, where necessary.
- (c) Screening – to remove large solids from the raw water.
- (d) Aeration - in some WTPs
  - To liberate dissolved gases like CO<sub>2</sub>, H<sub>2</sub>S etc.
  - To provide O<sub>2</sub> for oxidization of dissolved iron and manganese to their insoluble form.
  - To remove objectionable taste and odour.
- (e) Chemical treatment for conventional treatment process:
  - Coagulation – physical & chemical process that converts suspended & colloidal particles and dissolved solids to form microfloc using coagulant.
  - Flocculation – process to promote interaction of particles & form aggregates that can be efficiently removed in subsequent processes.
  - Sedimentation – gravitational separation to remove settleable suspended solids.
  - Filtration – separation of un-sedimented substances that are carried over from sedimentation tank.
- (f) Disinfection – destruction of pathogen (bacteria, viruses, etc.) using disinfectant.
- (g) Fluoridation – for prevention of dental caries in children.
- (h) Storage – gravitate or pump to consumers.

### 5.5.2 Selection of Treatment Process

- Quality of the raw water at the proposed intake should be studied over an extended period so that seasonal and yearly variations in the quality would be revealed and accounted for.
- The treatment shall be a suitable combination of processes as dictated by the quality of raw water. The latest Recommended Raw Water Quality Criteria (Table 1, NDWQS) provides a guide for raw waters that are amenable to conventional treatment.
- When the characteristics and constituents of raw water do not comply to the recommended criteria set in Table 1 of NDWQS, special treatment is required. Special treatment includes additional process such as algae control, pre-chlorination, ozonation, activated carbon absorption, sludge treatment etc. depending on what is needed to achieve treated water that complies to Table 2 of NDWQS.
- Samples of raw water must be collected at different times to cover the range of quality and fluctuation for physical and chemical analyses. The studies of the raw water should be subjected to, preferably at two weeks intervals and on all days/periods of abnormal weather, are:

- a. Physical, chemical and bacteriological analysis of samples of the raw water must be carried out. Tentative treatment process for the raw water is selected based on preliminary results.
- b. These processes are then tested out on samples of raw water using the Jar Tests to determine the type and approximate range of chemical dosages required for pre-chlorination (if necessary), adsorption, coagulation, disinfection and conditioning.
- c. Marble or Calcium carbonate stability test must be carried out to determine the alkalinity and pH which prevail at calcium carbonate equilibrium and thereby select the lime/soda ash dosage required.
- d. Samples of the treated water resulting from the jar and marble tests must be tested physically, chemically and biologically for compliance to the requirements of treated water in NDWQS Table 2.
- e. The analysis in (d) above should be carried on not only on the treated water from the jar test which appears clearest and with most rapid settling time but on the treated water from the next three or four best tests especially during the beginning stages of investigations to ease in the final decision making.
- f. Jar test must also be used as a basis of selection of the most economical method of treatment that will produce treated water comply to NDWQS Table 2.
- g. Salinity test shall be conducted as well.

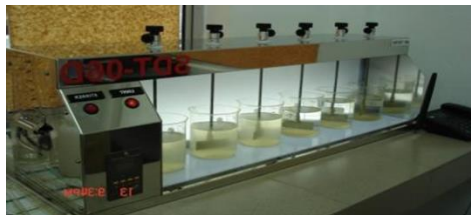

- The use of polymer in treatment process is to be avoided in view of the risk of filter choking.
- Inclined plates or tube settlers is not preferred in the design of new WTP. They may only be considered/recommended for upgrading works of existing plant.

## 5.6 Pre-Sedimentation

For raw water with high content of suspended solid, pre-sedimentation is provided.

- a) Design calculations are provided to show that the proposed pre-sedimentation basins are sized according to the treatment plant capacity and suspended solids content.
- b) The pre-sedimentation basins have hopper bottom or be equipped with mechanical moving sludge removal apparatus.
- c) Have a means of dewatering the settled sediments.
- d) Are designed such that the incoming water is dispersed evenly across the tank width to prevent short circuiting.
- e) There is a by-pass around each pre-sedimentation unit.
- f) The pre-sedimentation basins are designed with a minimum of three (3) hours detention time (actual detention time is to be determined through sedimentation tests).
- g) Duplicate pre-sedimentation basins are provided to allow 1 unit to shut down for maintenance.

- h) Isolating valves are provided for shut down for maintenance.

## 5.7 Chemical Dosing System

1. All chemical feed piping and equipment (chemical resistance type) and batching tanks (2 nos. with stainless steel mixers) shall be constructed or lined with materials suitable for use with wide range of chemicals to allow maximum flexibility and to be provided with insect-proof netting.
2. All chemical dosing system must be carried out in solution for powdered chemicals and preferably liquid chemicals where necessary, depending on WTP location and logistics needs, using metering pumps (**1 duty and 2 standby**) for plant of 1 MLD and above.
3. For plant below 1 MLD capacity, all chemical feed system shall in general be by gravity and be manually operated, with 1 duty and 1 standby.
4. The dosing system shall include duty and standby line c/w with y-strainer, PRV, back pressure valves, pulsation dampers, calibration/measuring cylinders, local control panel, cabling works and other necessary items.
5. The dosing system shall be designed based on suitable solution strength that will not cause pump blockage and tank size for optimal and ease of operation. The system shall cater for at least 8 hours continuous operation.
6. Pre-soda dosing, if required, shall be dosed before the coagulant.
7. Post soda dosing, if required, shall be after chlorination.
8. Chlorination system for plant < 5 MLD, use calcium hypochlorite and plant  $\geq$  5 MLD, use liquid chlorine gas system.
9. Electro-chlorination system (100 % standby for electrolyser & hydrogen ventilation) shall consist of electrolyser, chillers, brine tanks, softeners, rectifier, brine dosing system, service water, duty & standby dosing lines, dosing pumps (1 duty, 1 standby), local control panels, hydrogen gas detector, cabling works & necessary items, if used. Standby calcium hypochlorite tanks (2 nos.) c/w dosing system (1 duty, 1 standby) with storage lasting at least 24 hours or liquid chlorine gas dosing systems in case EC system encounter problem.
10. All mixing tanks are provided with waist height loading platforms to facilitate discharging of chemicals by hand.
11. The mixing tanks & dosing area are provided with adequate drainage & washing facilities for easy cleaning.
12. Duplicate fluoridator equipment are to be provided if fluoridation is required. It is required to check with the Medical Department on the requirement for fluoride dosing.
13. Duplicate chlorinators with auto-change over are provided.
14. The dosing system shall be designed to provide the following levels of constituents in finished water: -
  - a. free residual chlorine shall not be less than 0.2 mg/L at any point of the distribution system.
  - b. pH value: 6.5-9, depending on disinfection regime and corrosiveness of the water.
  - c. Fluoride residual: 0.4 - 0.6 mg/L.
  - d. Residual aluminium shall not be more than 0.2 mg/L.
  - e. And all other standard requirements in Table 2 of NDWQS.



WTP < 1 MLD  
Gravity dosers

WTP ≥ 1 MLD  
Metering pumps

## 5.8 Chemical Storage

1. There is provision of chemical storage for 3 months operation (for powdered coagulant) and 1 month operation (for liquid coagulant).
2. WTP of 5 MLD & above, adequate aisle space shall be provided for easy access using forklift.
3. The chemicals shall be easily moved into storage, out of storage and to the mixing tanks on a first-in-first-out basis.
4. The entrance to the chemical store shall be large enough to allow the supply truck to reverse into the building to facilitate unloading of chemicals. A ramp must be provided at the entrance for movement of the supply truck.
5. Automatic steel roller shutter door shall be provided.
6. All plant shall be equipped with forklift or suitable equipment.
7. All plant shall be equipped with hand powered trolley for transfer chemical cylinders, bags, equipment up to 300 kg.
8. Adequate natural ventilation shall be provided by using fixed louvres clear glass windows at the top. Openings of the louvre windows are covered with insect-proof netting to prevent entry of insects. Bird netting shall also be provided to prevent entry of birds.
9. For safety precautions, PPE, emergency eyewash and shower and all relevant safety and hazards warning signs must be provided/displayed at the potentially hazardous location.
10. For chlorine storage and facilities:
  - a. The chlorine dosing facilities & the chlorine store shall be isolated from the rest of the facilities.
  - b. For plant of 5 MLD & above, a separate building shall be provided for dosing & storage of chlorine.
  - c. Corrosion resistant materials such as plastics, fibreglass or stainless steel shall be used as construction material in the chlorine room.
  - d. Hoist & other mechanical equipment must be protected against corrosion.
  - e. They are of fireproof construction, remote from fire risk & must be located on ground floor.
  - f. There is a minimum of two access door opening outwards.
  - g. Adequate corrosion resistant extractor fans are provided with switches installed outside the room.

- h. All chlorine stores and dosing rooms are provided with chlorine leaks detectors with audible alarms located outside.
- i. For plants 5MLD and above capacity, a chlorine neutralization gas scrubbing system is provided.
- j. For plants below 5MLD capacity, auto-shut down valve system must be provided.
- k. Ammonia solution shall be provided for detection of chlorine leakage.



CHLORINE SCRUBBER SYSTEM



- 11. Fluoride dosing facilities and store shall be isolated from the rest of the facilities. Fluoride dosing shall be carried out in solution form.

### 5.9 Filtration

General requirement for design of filter such as filtration rate, length and breadth ratio, size filter, tank depth, free board, water depth, head loss, media depth, pipes sizing and recommended flow velocity of the pipe and channel, backwash system, air bower capacity shall be provided.

### 5.10 Operation and Maintenance Requirement

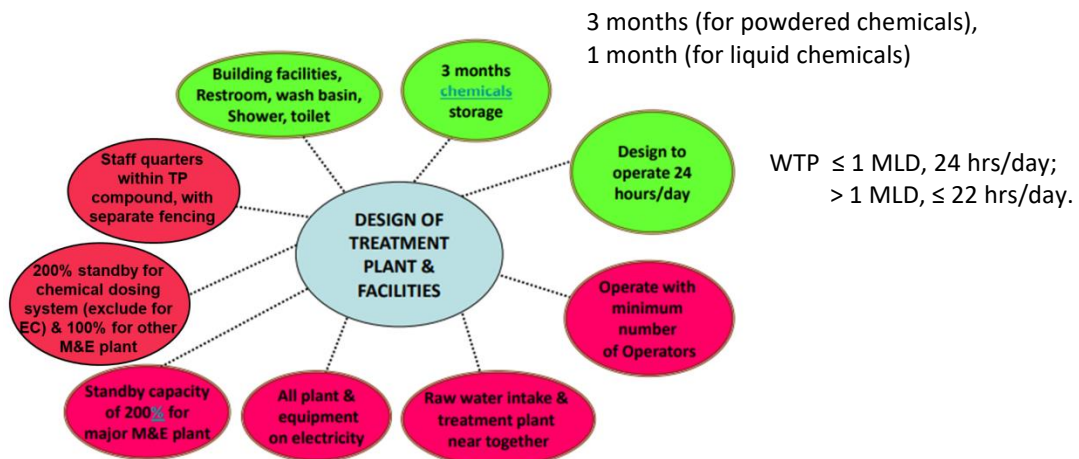

### 5.11 Layout

- (a) Layout of all treatment units, control house, chemical stores, pumping stations and other appurtenances should be compact and to allow optimum efficiency in operation and maintenance of the system with a minimum number of operators.
- (b) A minimum of two (2) treatment trains is provided, operating in parallel.

- (c) Hydraulics profile of the WTP should be such as to prevent excessive head loss and excessive velocities and to enable gravity flow from one process unit to another wherever possible. All connections between the various treatment units are direct and as short as possible.

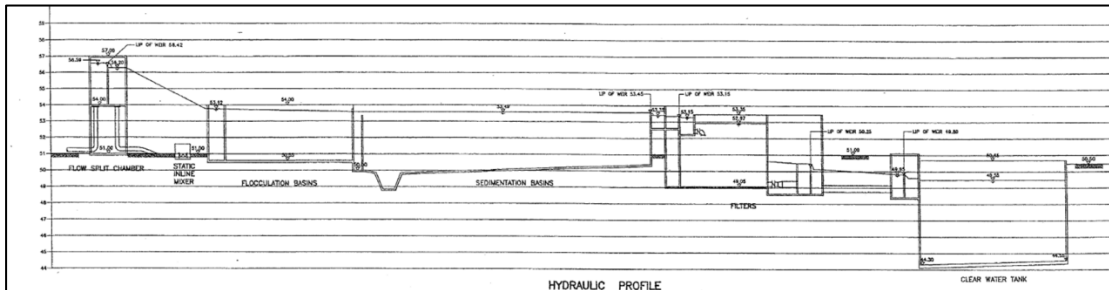

- (d) A schematic diagram of the proposed system must be provided in all cases of design, showing all levels, pipe type, sizes and lengths, hydraulics gradient, reservoirs levels and capacities, pumping heads and capacities, the highest and lowest points of consumers service, including all chemical feed systems.
- (e) Full consideration is given to easy inspection, operation & maintenance of entire treatment facility by locating the process units which require more attention than others close to one another and next to operations building.
- (f) Covered walkways shall be provided to connect the individual treatment units.
- (g) Provision should be made for adequate isolation of individual treatment units and adequate working area for purpose of maintenance and repairs.
- (h) Access & lifting devices for removal of all major equipment are provided.
- (i) Adequate walkways with safety handrail along the filters, sedimentation tanks & flocculation basin are provided. Safety handrails are provided at all structures high above ground.
- (j) Adequate air scour and wash-water rates should be provided for thorough and effective backwashing of filter media. Wash water lines should be provided with a rate control valve.
- (k) In all cases, provisions for future expansion and augmentation of the treatment plant and facilities shall be provided for.
- (l) Due consideration should be given to the architectural design and layout of the buildings so as to project an image of cleanliness, efficiency and reliability.
- (m) Sanitary and sludge handling facilities and drains should be sited so as not to cause contaminations.
- (n) Every WTP shall install 5 units of water meters at: -
- a. Raw Water Pump
  - b. WTP Outlet
  - c. For Filters Backwash use at WTP with backwash tank or supply main before entering WTP (without backwash tank)
  - d. For Headworks use at service pipe
  - e. Discharge pipe to sludge facilities
- (o) Operation units such treated water pumping station & generator house are located separately from the main operations building to reduce noise problems.

- (p) Premix access roads and service roads of adequate width and adequate parking space for cars and motorcycles are provided.
- (q) Adequate drainage facilities are provided for discharge of surface water, overflows from the treatment facilities, wastewater flows & scour flows.
- (r) Security fencing, gates, adequate external lightings and fire protection are to be provided.
- (s) Signboard is to be provided at WTP and booster pump station as well as at the junction of the access road to the plant or booster pump station. Separate signboard is to be provided for raw water intake and reservoir, if located outside of WTP's compound.

## 5.12 Operation Building

- (a) Building is large enough to accommodate the plant staff for regular inspection and maintenance.
- (b) Office & meeting room (if provided) have adequate furniture and are air-conditioned for larger treatment plant.
- (c) M&E spares and tools store is furnished with proper steel racks.
- (d) A water pond for monitoring water quality is to be provided. If there is no provision for water pond, the lobby should have clarity bowl, main instrumentation panel and aquarium for monitoring water quality.
- (e) Schematic drawing and general layout of WTP with the relevant data are provided in the lobby or control room.
- (f) 3D model shall be provided for WTP  $\geq$  10 MLD.
- (g) Control room shall be air-conditioned.
- (h) Adequate separate toilet & bath facilities for men and ladies (for staff and visitors) and sufficient locker facilities provided in the rest room or pantry.

### 5.12.1 The Laboratory

- (i) The laboratory is provided with the following:
  - Purpose-built wooden cabinets for storage of chemicals & water testing equipment.
  - Sufficient work benches with colour formica finish table-top complete with sinks.
  - Fridge.
  - Proper water supply & drainage facilities.
  - Direct sampling facilities for raw water, settled water, filtered water and treated water.
  - Air-conditioning and with adequate furniture.
  - All laboratory equipment and apparatus necessary based on latest JBALB requirement as **Appendix A**.
  - All testing reagents and tablets, standard solutions and other necessary laboratory chemicals for testing instrument calibration/maintenance purpose.
  - Online water quality monitor/ analyzer - residual chlorine analyzer, pH analyzer (raw, settled, filtered & treated), turbidity meter (raw, settled filtered & treated), residual alum analyzer (raw, settled, filtered & treated), fluoride analyzer for WTP  $\geq$  5 MLD.
  - Sampling pump must be installed at the appropriate location. For example, filtered water sampling pump must be located at the outlet pipe of the filter.

- Sampling pumps must be installed at places which are easy to be accessed by the plant operator.
- Sampling pump must be installed at one duty and one standby, if there are different treatment packages/module for the plant, sampling must be done for every treatment module.
- Stream current detector/monitoring (with standby unit) complete with PID controller for monitoring of raw water and automating dosing control of alum/PAC/ACH for plant with high fluctuation in raw water quality.
- All WTPs are to be equipped with local charge analyzer (LCA).

### **5.12.2 Filter Operating Gallery**

The filter operating gallery is provided with the following:

- a) Large clear glass aluminum casement windows & panels preferably from ceiling to floor on the side facing the filters, for easy viewing of filter operations.
- b) Separate operating console for each filter.
- c) Common dial indicators for wash water flow rate, air scour, etc. of at least 300 mm dia. or digital indicators.
- d) Direct access door between the filter operating gallery and the filters.
- e) Filter operating consoles arranged neatly and in such a manner that the operator can watch the filters washing operation easily while operating the filter consoles.
- f) The filter pipework gallery is provided with adequate ventilation & lighting, access stairs, drainage facilities, minimum floor gradient of 1 in 500 sloping towards the drain pipe, neat arrangement of pipework with adequate space for easy access, installation, valves operation, inspection, maintenance or repair and pipework are painted according to the required colour code.
- g) The filtered water outlet chamber has chamber lined with white glazed tiles on the inside, inspection opening with clear Perspex covers and vent openings to prevent water vapour collection on underside of the Perspex covers.

**Appendix A**

No	Parameter Analysis	Equipment	Glasswares	Accessories:	Reagents	Remarks
1	Free Chlorine	Portable Photometer and Comparator	Sample cells	Plastic stirring rod, test discs for comparator, standard verification kit and delicate task wipers Test Disc Chlorine DPD Test Test Disc PH (4.4-6.3)	Tablet DPD 1	Reagents/tablets for minimum 3 months stock
2	Total Chlorine				Tablet DPD 4	
3	pH (4.4-6.3)				Methyl Red	
4	pH (5.2-6.8)				Bromocresol purple	
5	pH (6.0-7.6)				Bromothymol Blue	
6	pH (6.5-8.4)				Phenol Red	
7	Iron				Iron Low Range Tablets	
8	Manganese				Manganese Low Range Tablet 1 Manganese Low Range Tablet 2	
9	Aluminium				Aluminium Tablet 1 Aluminium Tablet 2	
10	Turbidity	Benchtop Turbidimeter and Portable Turbidimeter	Sample cells	Delicate task wipers		
11	Colour	Nessleriser (For Colour)	Pair of Nessler tubes for Colour test	HAZEN/APHA Disc (0-250 mg pt/l) Delicate task wipers		
12	Fluoride (if applicable)	Nessleriser (For Fluoride)	Pair of Nessler tubes for Fluoride test	NOM DISC, Fluoride; 0-1.6mg/l Delicate task wipers	Fluoride A-Z tablets Fluoride excess AL tablets	Reagents/tablets for minimum 3 months stock
13	Jar Test	Jar Tester (6 Paddle) Adjustable Volume Micropipette (1 mL) (2 unit) Adjustable Volume Micropipette (5 mL) (2 unit) Adjustable Volume Micropipette (10 mL) (2 unit) Syringe (1ml) (2 unit) Syringe (10mL) (2 unit) Laboratory Scale (Analytical Balance) Magnetic Stirrer Plate	500 mL glass beakers (6 unit) 500 mL glass graduated cylinder (1 unit) 100 mL glass graduated cylinder (1 unit) 100 mL glass beaker (8 unit)	Cellulose filter paper (0.45 micron) Pipette tips (1ml) Pipette tips (5ml) Pipette tips (10ml) Filter funnel Funnel Holder Magnetic Stirrer (7mm x 30mm)		
14	Specific Gravity	Hydrometer (for Liquid polyaluminium chloride TYPE 1) (1.13-1.23 g/ml) Hydrometer (for Liquid polyaluminium chloride TYPE 2) (1.18-1.35 g/ml) Hydrometer (for Liquid polyaluminium chloride TYPE 3) (1.32-1.38 g/ml) Hydrometer (for Liquid Aluminium Sulphate) (min. 1.31 g/ml) Hydrometer (for Soda Ash Solution) (1.0-1.2 g/ml) Hydrometer (for Aluminium Sulphate Solution) (1.0-1.2 g/ml) Hydrometer (for Chlorine Solution) (1.0-1.2 g/ml)				Depend on chemicals to be used.
15	Salinity	TDS Meter (with temperature measurement)		TDS calibration solution		If expect saline intrusion.

## 6 Quarters

- (a) Usually for accommodation of WTP operators working in shifts.
- (b) If WTP is located near an existing community/town, the quarters may be located at/near the community/town for social reasons.
- (c) If WTP is at a remote area, quarters may have to be in the vicinity of, but outside the compound of the WTP, with gate and fencing. Sufficient street lighting should be provided leading from the quarters to the WTP.
- (d) Quarters to be provided with electricity, lighting, water supply and internal plumbing. Those facilities shall be separate installation from WTP. (Occupant must apply their individual electricity connection meter with SEB/SESCO)
- (e) Quarters to be designed to follow the State Pre-Approved Plan (SPAP) standard with minimum three (3) bedrooms and floor area.
- (f) Quarters to be provided with furniture as per standard furniture list.

**TABLE I**

Class F Quarters			
Item	Article	Quantity	
1.	Easy Chairs	4	
2.	Occasional table	1	
3.	Dining table	1	
4.	Chairs standard	6	
5.	Kitchen table	1	
6.	Kitchen cupboard	1	
7.	Kitchen sink with tap	1	
8.	Ceiling fan	1	
9.	Refuse bin	1	
	<b>Bedrooms</b>	No. 1	No. 2 & 3
10.	Bedsteads	1 double	2 single
11.	Foam rubber mattresses	1	2
12.	Mosquito frames	1	2
13.	Dressing table with mirror	1	2
14.	Wardrobes	1	2
15.	Ceiling fan	1	2
16.	Washstand with tap	1	
17.	Toilet bowl	1	
18.	Shower head	1	

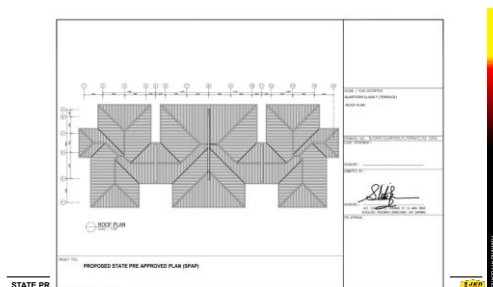

## **7 Sludge and Wastewater Disposal**

The treatment and ultimate disposal of sludge and wastewater are rapidly becoming an integral part of the design and operation of water treatment plant facilities.

- (a) Environmental Quality Act 1974: Environmental Quality (Industrial Effluent) Regulations 2009 - shall apply to any premises which discharge or release industrial effluent or mixed effluent other than premises as specified in First Schedule.
- (b) Industrial effluent: any waste in the form of liquid or wastewater generated from manufacturing process including the treatment of water for water supply or any activity occurring at any industrial premises.
- (c) Sludge: any deposit of particulate matter settled from any liquid, including deposit resulting from physical, chemical, biological or other treatment of water or industrial effluent or mixed effluent.
- (d) Restriction on discharge or disposal of sludge - Clause 23. (1) No person shall discharge, or cause or permit the discharge or disposal of any sludge generated from any production or manufacturing process, any industrial effluent treatment system or water treatment plant onto or into any soil, or surface of any land, or into any inland waters or Malaysian waters without the prior written permission of the Director General.
- (e) Consultant to check and comply with NREB's requirement on sludge treatment facilities and disposal.
- (f) The options for ultimate disposal of sludge and wastewater include: -
  - a. To dedicated landfill
  - b. To municipal sanitary landfill
  - c. To sanitary sewer
- (g) With high land costs and more restrictive measures for discharge into sanitary sewers utilities throughout the world are looking into other beneficial use programs for sludge and wastewater, not only as a cost-effective alternative but also as a publicly acceptable management practice. Some of the possible options for reuse of sludge/wastewater are as follows: -
  - a. Commercial products
  - b. Co-use with biosolids
  - c. Land application

## 8 Mechanical Works

### 8.1 Parameters for Pumps Selection

- (a) Capacity of the pump to be provided shall consider extra allowance of minimum 10% of plant design capacity.
- (b) Design of pump operation configuration shall consider 200% standby.
- (c) Capacity (Flow Rate) → Refer Pump Performance Curve
- (d) Total Head → Total Static Head + Friction Loss (Pipe) + Minor Loss (Fittings)
- (e) Pump Type → Surface Pump Vs Submersible Pump
- (f) Speed → Operation Note: Preferably 1500 Rpm and below For Raw Water Pump
- (g) Suction/NPSH → For Pumps, Suction Lift Must **Not Exceed 5 Meters** be including all losses.
- (h) Prime Mover (Motor/Engine) Output → Refer to Rated Power in Pump Catalogue
- (i) Driving motor power to be not less than 110% of the maximum power requirement of the driven element.
- (j) Raw Water / Treated Water Condition (I.E. Ph Value, Turbidity, etc.)
- (k) The output of the pump shall be obtained with cut down impeller. Full size impeller should not be used to achieve the specified duty point.
- (l) The impellers shall be designed for high efficiency. The pump offered shall operates and remain in the stable region of the pump characteristic curve ranging 70% to 120% of Best Efficient Point (BEP) of the pump's rated or design flow rate.
- (m) The pump shall be fitted with impeller/casing wear rings.
- (n) Common head, e.g., 10m, 20m, 35m, 55m etc. and Common rated power, e.g., 11kW, 22kW, 45kW, 75kW. Applicable to Dosing pump also.
- (o) Pre-tender marketing research (Consultant or In house design) to avoid future argument of pump selection during implementation stage. (Pump selector online for multiple brands)
- (p) Suction and discharge piping shall be sized so that velocities are not excessive. The velocities of 2.4 m/s in discharge piping and 1.5 m/s in suction piping are reasonable maximum. Economic efficiency should be considered when selecting the discharge-side velocities in the case of long piping and extended periods of operation.
- (q) Direct connection of elbows to the suction port of the pump shall be avoided and a short straight pipe shall be installed if the elbows is necessary to be installed.
- (r) For negative suction, and independent suction pipe shall be independent for each pump.

E.g., Power Required for Pump:

$$P = C \times \text{Shaft Power}$$

where, P = Power required for the prime mover

C = Excess Power Safety Factor (Motor: 1.10 – 1.30 / Engine: 1.15 – 1.30)

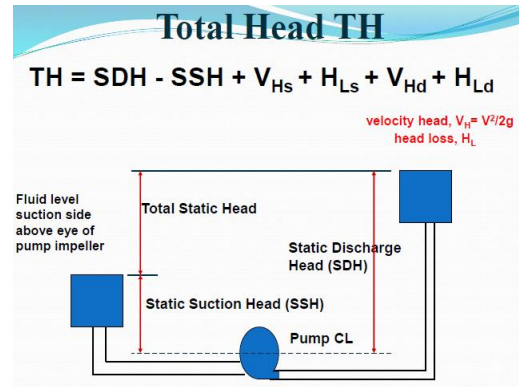
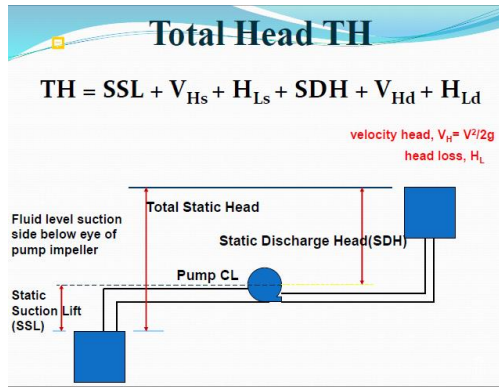
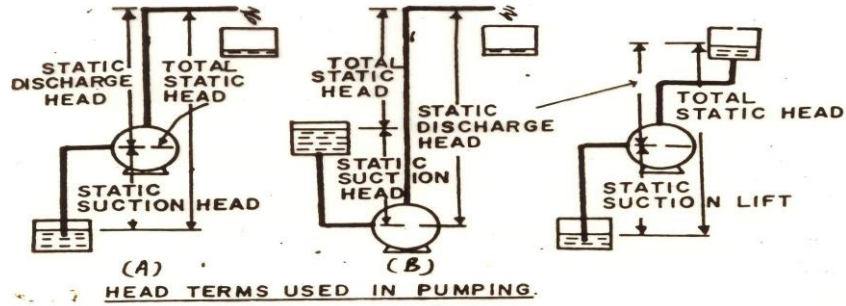

- (s) Eccentric reducers in pump suction piping (Tapered at bottom) to prevent air-pocket.
- i. Pump nozzles are smaller than inlet / outlet piping. That is why we need to use reducers and expanders at the pump suction and discharge piping. Horizontal surface allows hydraulic transportation of air.

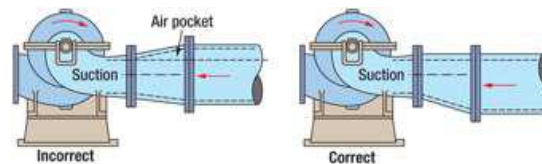

- (t) Separate suction lines are to be provided when pumps are operating under negative suction heads. (Same size of pump)

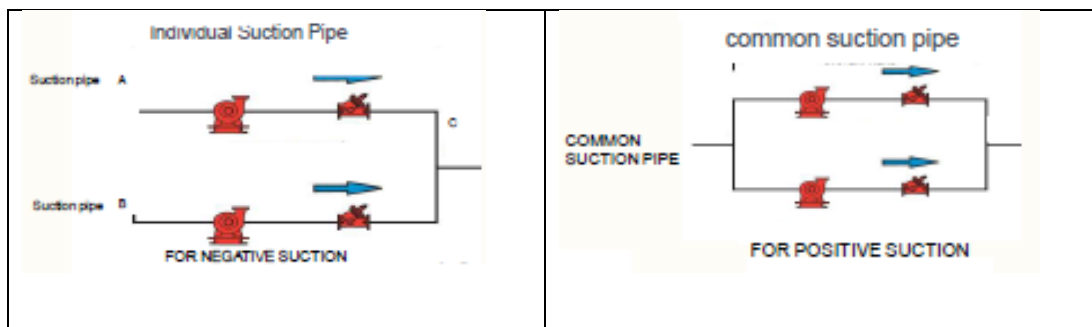

### 8.1.1 Raw water pump head design

To consider Lowest River Water level, i.e., low water level

- i. The intake is located at a place from where it can draw water even during the 1 in 50-year 7-day low flow.
- ii. The intake structure is located at sufficient water depth so as to be able to keep the raw water pumps low flow (7-day Q50).
- iii. Pump base should be sited at minimum low water level at Pontoon or Jetty Intake (Fixed & Flexible Pump Mounting).

### 8.1.2 Treated Water Pump Selection

- a) Preferably Horizontal Split Casing (Single stage double entry volute centrifugal pump) compared to End suction. Design is mechanically balanced, more long lasting.
- b) Preferably constant speed pump (auto trans) to fill storage reservoir, variable speed (VSD) to serve direct pumping to consumer.

## 8.2 Pump Installation Layout

Design of pump installation layout shall consider to use fittings that produce minimum losses.

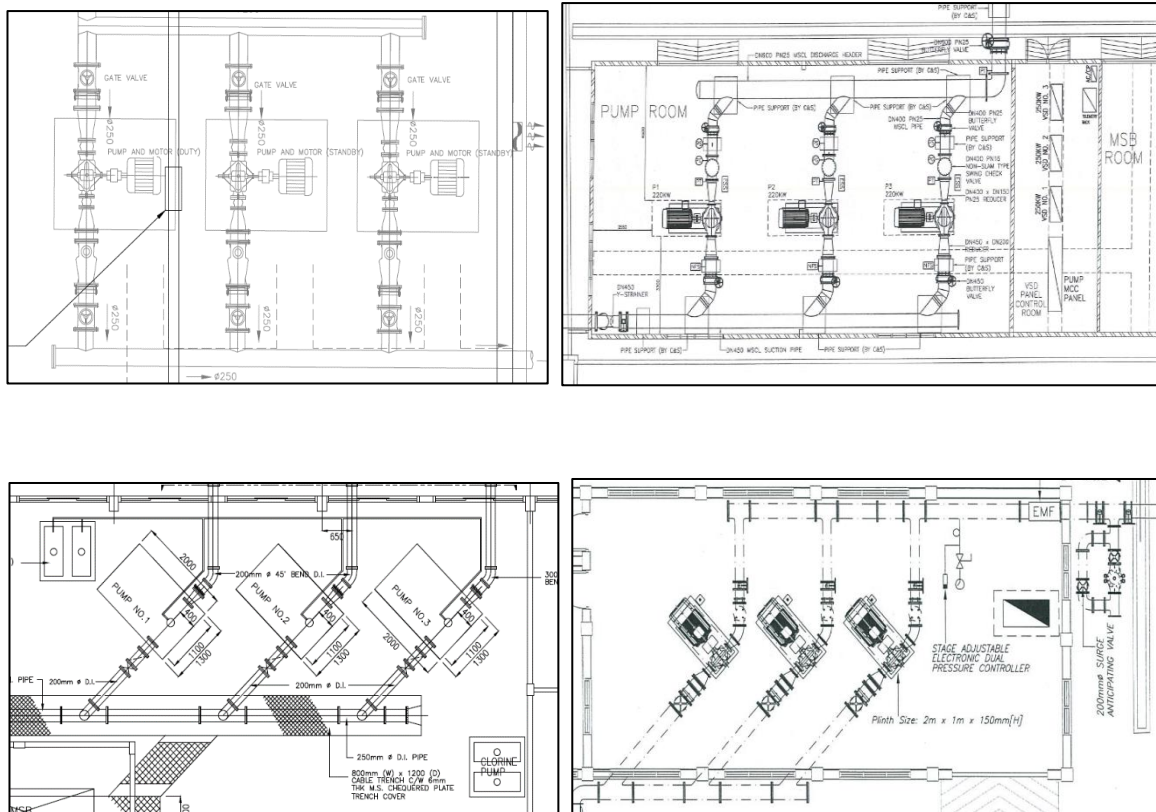

Typical Pump Layout

### 8.3 Mechanical Seal vs Gland Packings (Surface Pump)

- a) Raw water: the pump to be fitted with packed stuffing boxes incorporating lantern rings which include internal flashing by the water being pumped. PTFE type materials.
- b) Treated water: Mechanical Seal (tungsten carbide vs tungsten carbide or silicon carbide vs silicon carbide surfaces).
- c) The submersible pump shall be fitted with double mechanical rotating shaft seal system running in an oil chamber.

### 8.4 Motor Starter Requirement

General Conditions of Electrical Supply and Electric Motors and Motor Starters Specification  
Ref: PWD/E1/05, year 1979.

- a) Supply Conditions  
Alternating Current, 50 cycles (Hz), 230 volts single phase and 400 volts three phase 4 wire. (Voltage variation allowed - plus or minus 5%).
- b) Up to and Including 1 HP  
Single phase 230-volt motors may be used with direct-on-line starting. Starters must be used for motors over 1/2 H.P.
- c) Up to and Including 3 HP  
May be three phase squirrel cage type with direct-on-line starters.
- d) Over 3 HP Up to but not Including 10 HP  
May be of the squirrel cage type but must be fitted with star/delta or Auto transformer type starters.
- e) HP and Above
  - i. May be of the Auto Trans or VSD fitted with mechanical devices to prevent quick movement of the starter switch and starting without all resistance or reactance in circuit.
  - ii. In clarification of the requirements for motors of 10 HP above, motors other than wound rotor type may be used providing the associated starting equipment limits the starting current to not more than 200% of full load current.
- f) All motors and electrical equipment to have a **Power Factor of at least 0.85** but 0.9 is preferred.

### 8.5 Variable Speed Drive (VSD)

- a) VSD installed at enclosed area with higher heat dissipation rate than operating temperature as stated in the VSD catalogue shall be provided with proper air conditioning system.
- b) The air-conditioning shall run at alternate twelve (12) hours duration and provided with automatically change configuration.

- c) Complying **Sarawak Electricity Ordinance** The Electricity (State Grid Code) Rules, 2003 - PC4.3 Harmonics

**d) Standard Guidelines:**

- i. IEEE 519 1992 Harmonic Control in Electrical Power Systems
- ii. Output Peak Voltage and rise time to be compatible with motors complying with IEC 60034-17 (General purpose motors), as measured at motor terminals with motor cable type and length specified in the tender documents.
- iii. IEC Quality Assessment System for Electronic Components
- iv. IEC 60146: Semiconductor converters
- v. IEC 60391: Marking of insulated conductors.
- vi. IEC 60529: Degree of protection provided by enclosures (IP Code)
- vii. IEC 60801-2: Electronic compatibility for industrial process measurement and control equipment. Part 2: Electrostatic discharge requirements.
- viii. IEC60721-3-3: Class 3C3 High Grade conformal coated PCBs

- e) Requirement of VSD features: -

– **With or Without Low Harmonics Drives**

- i. Total harmonic distortion (THDi) 5% - 7% or lower <2% - 4%. Normal drive THDi>20%
- ii. Harmonics filters go a long way in making electrical usage more efficient and effective.

– **Active vs Passive Harmonics Filters**

- i. Passive harmonics filters are the more common devices used in a variety of capacities and voltages. These filters utilize components like inductors, capacitors, and resistors. Passive filters generally filter noise on a single variable speed drive. They eliminate harmonics before the electrical current reaches' equipment.
- ii. Active harmonics filters can work with many variable speed drives and actively reduce noise by constantly monitoring electricity and injecting currents to mitigate harmonics. Active filters are ideal for a system with many non-linear loads.
- iii. While these filters can handle a great deal active harmonics filter generally cost a lot more than a passive filter. Active filters also do not require a pre-study of the current's harmonics prior to installation.
- iv. One harmonic filter to be associated with One unit of pumpset.

– **Build-in or standalone harmonics filters → Concern on Space Constraints**

- i. Brake chopper (IGBT) option (Limits the load on the intermediate circuit in the case the motor acts as a generator)

## 8.6 Surge Suppression System

- a) Prevention of transient pressure or surges shall be one of the first considerations in the design of the pumping system.

- b) Surge suppression systems with adequate air valves and vacuum relief valves along the pipeline shall be provided to protect against surge or water hammer which may cause damages to the pumps and pipeworks.
- c) Selection of appropriate type of surge suppression system shall be done after a comprehensive study conducted during the design stage.
- d) Surge Vessel: 2 nos. of air compressors (1 duty, 1 standby) complete with air receiving tank, control panel.
- e) Surge analysis report required to be submitted.
- f) Surge Anticipator Valves: combined air and vacuum relief valve



**Surge Anticipator valve**



## 8.7 Cranes

- a) All heavy equipment, including pipework shall be provided with means for installation and removal of the equipment by appropriate lifting devices.
- b) Cranes are preferably to be electrically-operated unless specified.
- c) Criteria and standards as follow shall be used in determining the application of cranes: -
  - i. Monorail cranes are used when a single degree of movement is required and the centre line of the equipment is in line with the entry or exit of the building
  - ii. The beam can be either "U" type or "I" type.
  - iii. Gantry cranes are preferably to be used when two degrees of movement is required.
  - iv. The electrical lifting and travel for gantry cranes shall be used when the load is more than two (2) tonnes.
- d) Cranes shall be sized to withstand SPAN 1.25 times its Safe Working Load (SWL).
- e) Overhead travelling cranes
  - i. Capacity of the crane is the maximum weight of the component to be lifted in the pumphouse.
  - ii. Safe working load (SWL) shall be at least 20% greater than the individual weight of the single pump or motor or other major equipment to be lifted.
- f) For SWL less than 10 tonnes, transverse crane bridge shall be a single box girder mounted on top of double channel end carriages.
- g) For SWL of 10 tonnes and above, transverse crane bridge shall be a double box girder with double rail crab.

- h) Height of a plant area or the building shall be sufficient such that the largest equipment may be lifted over or around.

### 8.8 Forklift

- a) Forklifts shall be provided for the purposes of chemical loading and unloading within enclosed reception areas.
- b) Forklifts provided shall be battery-operated type unless specified.
- c) Sufficient areas for the movement of forklift within the areas shall be considered during the design stage.

### 8.9 Fire Fighting Services

- a) Designs for firefighting services provided shall comply to Uniform Building By-Laws (UBBL) 1984 and requirements by Jabatan Bomba dan Penyelamat Malaysia (BOMBA).
- b) Equipment provided for firefighting services shall comply to Malaysian Standards for Fire Safety and Protection.

### 8.10 Cathodic Protection

- a) The design of all main pipelines shall take into consideration of corrosion control when necessary.
- b) Testing for soil corrosivity should be required and cathodic protection systems shall be provided where there may be risk of corrosion of the iron pipes.
- c) The report for soil resistivity measurement survey and corrective survey shall be provided.
- d) Design of cathodic protection systems provided shall follow the code of practice for cathodic protection.
- e) The design of the cathodic protection system shall be for a period of thirty (30) years and comply to BS 7631-1: 1991 and National Association of Corrosion Engineers (NACE SP0169-2007).

### 8.11 Pressure Gauge

Oil-based dial of pressure gauge is preferred. Quick-type push fit design is preferred / equipped with stopcock to prevent the gauge under pressure all the time.

Install before the discharge valve

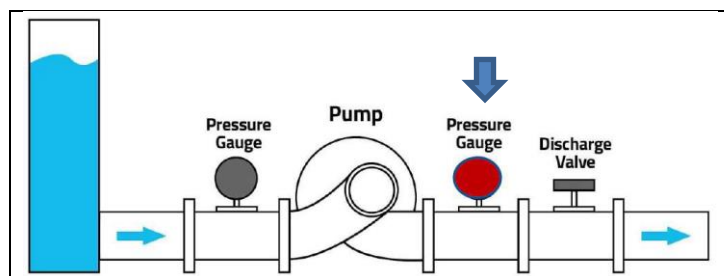

## 9 Electrical Works

### 9.1 Power Supply

- (a) Tapping off from SESCO/SEB power supply i.e., Existing SESCO Substation, High Tension Line, Low Tension Line.
- (b) Provide standby generator for backup power supply.
- (c) In cases of SESCO power supply is not available, generators shall be provided to supply electric power to the whole plant / booster station.
- (d) If power supply to the treatment plant site is available, provision shall be made for separate electricity supply substation building in an area within the treatment plant compound.
- (e) SESCO capital contribution for substation, transformers, switchgear, ring main unit (RMU), HT/LT Overhead Line, distribution pillar, submain cable, HT/kwh meter connection.
- (f) Design and application to SEB shall comply to the requirement of latest Handbook on Application for Electricity Supply, SEB Distribution Services Circular and Approved List of Materials.
- (g) Access to substation shall be separate from the access to WTP and booster station.

### 9.2 Sizing of Motor

- (a) Motor specification:
  - i. High efficiency, Class EFF 1 or better
  - ii. Preferably Squirrel cage type motor
  - iii. Variable speed motor
  - iv. Class F insulation
- (b) Motors starters Direct-On-Line, Star-Delta, Auto-Trans, Soft starter, Variable Speed Drive
- (c) Power supply: 415V; 50 Hz; 3Phase
- (d) Motor power ranges 3.7 kW – 450 kW
- (e) Protection system: overloading, high temperature, under voltage, single phasing etc.
- (f) Thermistors (for motors >100kw)
- (g) Anti-condensation heater (for motors >100kw, for surface pump)
- (h) Motor rated power not less than 10% in excess of driven equipment bhp.

### 9.3 Control Panel

- (a) MCC Panel for water pump shall be in the pumphouse or control room.
- (b) Control panel for raw water pump at Raw Water Intake shall be outdoor waterproof type.
- (c) Pump control panel shall be starting and control by Variable Speed Drive (VSD)

### 9.4 Generator

- (a) Design capacity of the generator set shall be designed for 100% standby for full operational of plant and systems.
- (b) Standby generator set shall be designed and sized to meet the calculated standby load requirement. The standby load shall include all equipment required for full normal operations during power failure.
- (c) The generator set rating to be selected shall be the highest calculated KVA which covering the Maximum Demand.
- (d) Generator minimum running load shall not be less than 30% of the generating rating.

- (e) Generator house shall be provided with Acoustic Treatment (acoustic door, air intake silencer, air discharge silencer).
- (f) Generator set installation shall be completed with AMF (Auto Main Failure) Board, Control Panel, Lead Acid Battery c/w battery charger.
- (g) Genset shall be provided with safety devices such as low lub oil pressure switch, high water temperature switch, overspeed and failure to start.
- (h) Genset panel shall be provided with Auto/Manual Change Over Switch.
- (i) Daily service fuel tank shall be provided for each generator set. The tank shall be accommodated for 8 hours operation.
- (j) Physical size of tank must allow for 10 - 20 % spare capacity.
- (k) Diesel fuel tank shall be provided adjacent to the genset house/room. The tank shall be sized for at least 7 days' supply for easy access areas and 21 days for remote areas, based on 8 hours operation.
- (l) Diesel fuel tank shall be provided with mild steel tank, skid mounted c/w filling connection, outlet connection, sight-glass level indicator, vent pipe, isolating valve, flowmeter, level sensor etc.
- (m) The tank shall be provided with easy access to facilitate loading of fuel from a fuel tanker.
- (n) Where possible, the tank shall be sited on higher ground to enable the fuel to be supplied by gravity to the engine of the generator.
- (o) Preferably an electrically operated fuel transfer pump shall be provided unless specified.
- (p) Genset installation shall comply with DOE requirement.
- (q) Firefighting system shall be provided at Genset House/Room and comply with BOMBA requirement.
- (r) All cables and fuel lines shall be neatly arranged in trenches with galvanized chequered plate covers and the trenches shall be well drained.

**Bomba Requirement**

Item	Description
1	Accessible to Bomba Fire Fighting Machine
2	Fire Hydrant
3	Bundwall (230mm thick) X height depending on the diesel quantity – should be able to contain the full quantity of diesel if leak from the tank.
4	Distance from building if less than 3 meter required a fire deflector wall (230mm thick X 3m high)
5a/5b	Oil trap / interceptor
6	"No Smoking" sign
7	Each pump island has 2 unit of 9kg dry power fire extinguisher
8	Hazard Code – for diesel "1202"
9	No grass / weed within 5m surrounding the diesel tank
10	Pump inside the bund wall which must have sand if there is no oil trap

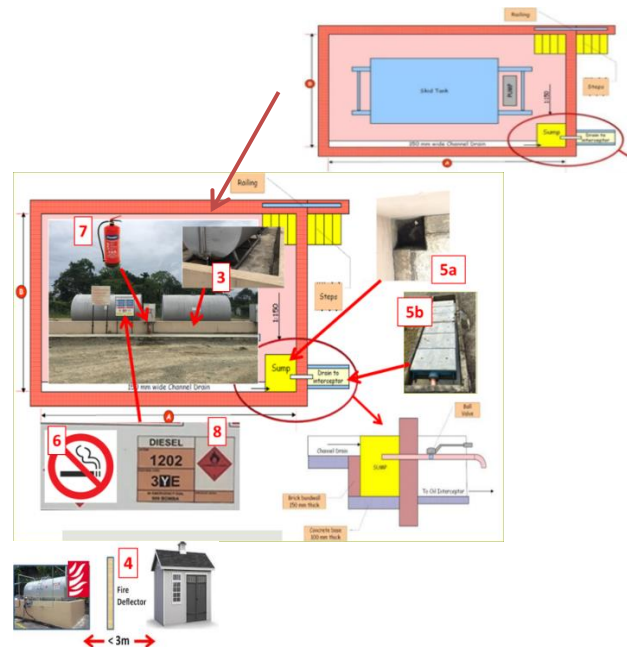

## 9.5 General Lighting and Power

- (a) Fluorescent lamp with metal reflector at pump room, generator room, MSB room.
- (b) Anti-corrosive fitting lamps shall be provided in the Chlorine room.
- (c) Emergency lighting shall be provided in the pump room, generator room, MSB room and other buildings.
- (d) Power socket installed at generator room and MSB room shall be metalclad type.
- (e) Compound lighting shall be provided at WTP, Booster Station and Reservoir areas.
- (f) Spotlight shall be provided at High Level Tank.

## 9.6 Earthing system

- (a) Complete earthing system shall be provided for generator, main switch board, sub switch board, MCC panel.
- (b) Earth electrode for neutral earth genset shall be connected to the genset main earthing busbar using 25mm x 3mm copper tape.
- (c) Earthing conductor from main earthing bar to earth chamber shall be 2 sets of copper tape (based on 50kVA breaker rating).

## 9.7 Lightning Protection System (LPS)

- (a) Methods and materials used for the construction and installation of the Lightning Protection System (LPS) shall comply to MS IEC 62305:2007 and IEC 62561.
- (b) Lightning protection systems shall be provided at high level tank, reservoir, pump house, chemical house.
- (c) Complete lightning protection system shall include air termination, down conductors and earth termination.
- (d) Unless otherwise specified, down conductor system shall be 25mm X 3mm annealed copper tapes installed in concealed of the structure.
- (e) Down conductors covered by insulated material shall not be installed in gutters or down-spouts.
- (f) The down conductor shall be installed in such a way that its path is as direct as possible between air termination system and earth termination system.
- (g) The number of down conductors shall not be less than two and should be distributed around the parameter of the structure to be protected subject to architectural and practical constraint.
- (h) If specified in the drawing and/or Bill of Quantities that natural conductors such as reinforcing bars and structural steelwork may be used as a down conductor system provided that they are electrically continuous and adequately earthed.
- (i) Proper care shall be taken into consideration in the route to earth when using a particular rod of the reinforcement steel as the down conductor. This is to ensure that the rod that is located on the same position will be used all the way down, thereby providing direct electrical continuity.
- (j) Steelwork within reinforced concrete structures is considered to be electrically continuous provided that the major part of interconnections of vertical and horizontal bars are welded or otherwise securely connected.
- (k) Connections of vertical bars shall be welded over a length not less than 30mm or properly clamped.

- (l) Electrical continuity of the reinforcing bars shall be determined by electrical testing between the uppermost part and ground level.
- (m) An additional conductor may be used to enhance the natural down conductor system if the overall electrical resistance is greater than 0.2 Ohms.
- (n) Additional conductor shall be bonded to the reinforcement bars by means of purpose made clamps conforming to IEC 62561 at 1-meter intervals.

## **9.8 Main Switch Board**

- (a) Main Switch Board shall be installed at MSB room and comply with SESCO requirement. The Switchboard room shall not be used as a store or for any purpose.
- (b) Separate feeder pillar/distribution board for compound lighting
- (c) Separate Distribution Board (DB) in pump house and switchboard room for general lighting and power
- (d) Fire protection system shall be provided at MSB room and comply with BOMBA requirement.
- (e) A rubber mat of minimum thickness 5mm and width 600mm shall be provided in front of the switchboard for its entire length.
- (f) Cable trench covers in MSB room shall using wood or concrete material.
- (g) Power Capacitor Bank shall be provided if there is motor load or MSB size 150Amps.
- (h) Nominal voltage:
  - 240 VAC for single phase system
  - 415 VAC for three phase 4-wire system
  - Variation: -10% / +5% (216V/375.5V - 252V/436V)
- (i) Frequency: 50 Hz +/-1%
- (j) The form of separation for Main Switch Board (MSB) and Sub Switch Board (SSB) shall be according to the requirement specified as below;
  - i) Rating below 150A – Form 2B
  - ii) Rating 200A to 500A – Form 3B
  - iii) Rating above 500A – Form 4B
- (k) The form of separation for Main Control Centre Panel (MCC) shall be according to the requirement specified as below;
  - i) Rating below 500A – minimum Form 3B
  - ii) Rating above 500A – Form 4B

## **9.9 Electrical Wiring**

- (a) The wiring system shall be surface galvanised iron (G.I) conduit with PVC cables. At corrosive area, either use concealed conduit or surface PVC conduit.
- (b) Underground cable shall be laid in cable trench at MSB room, genset house and pump room.
- (c) Fire resistant cable shall be used for: from genset to AMF board & from AMF board to essential main switch board.
- (d) HDPE pipe (Class D) shall be provided for cable entry to building i.e., pump house, MSB room, generator room etc.
- (e) G.I pipe sleeve (Class B) shall be provided for road crossing, drainage.

## 10 Digitalization

SCADA (or Supervisory Control and Data Acquisition) is a control system architecture comprising computers, networked data communications and graphical user interfaces (GUI) for high-level process supervisory management, while also comprising other peripheral devices like programmable logic controllers (PLC) and discrete proportional-integral-derivative (PID) controllers to interface with water treatment plant processes. This is an important control system architecture for digitalization of water treatment plant production processes and become an industry standard for water supply industries in the world.

SCADA monitoring is the essential part in water supply production digitalization. The main components of monitoring are as follows:

- a) Raw water intake – monitor raw water level, raw water pump condition, raw water pressure main flow and pressure;
- b) Chemical – chemical dosing pump condition and chemical dosing rate for each chemical used for treatment processes;
- c) Water quality – monitor water quality for raw water, settled water, clarified water, filtered water and treated water;
- d) Treated water – monitor treated water pump condition, treated water pumping main flow and pressure;
- e) High level tank – monitor HLT level sensor;
- f) Energy monitoring – current monitoring module, load and energy consumption etc.

The monitoring components are as follows:

- a) Sensing devices or sensors – for monitoring of water level, flow, pressure and water quality (including flowmeter and sensing devices in analyzer rack);
- b) PLC – an industrial microprocessor-based controller which can range from small modular devices with several inputs and outputs (I/O), in a housing integral with the processor, and which are networked to other PLC and SCADA systems. Its function in SCADA is as the controller located at each process area which act as the data concentrator for each process areas;
- c) Sampling pumps – to sample the selected water for water quality analysis which will be pumped to analyzer rack;
- d) Analyzer rack – a water quality monitoring rack which is normally placed in the WTP's laboratory;
- e) Human-Machine Interface (HMI) – to visualize the condition and data analytics of the collected data at the treatment plant. It is normally placed at strategic areas in WTPs for easy viewing by the operators;
- f) WTP SCADA – a central data processing and analytic hub for the WTP. It is placed at the WTP admin building;
- g) Gateway – act as a data transmission device from the WTP SCADA to the JBALB HQ Central SCADA.

Other supporting components are:

- a) Cabling works – due to excessive vibration in the treatment house, cabling works are required to transmit data from the sensing devices to the PLC and WTP SCADA;

- b) Pedestal panel – a housing unit for the transmitter, surge protection and accessories required for level sensors;
- c) MCC (Motor control centre) panel – installed for monitoring of pumps, mixers and energy monitoring.

The process can be simplified as follows:

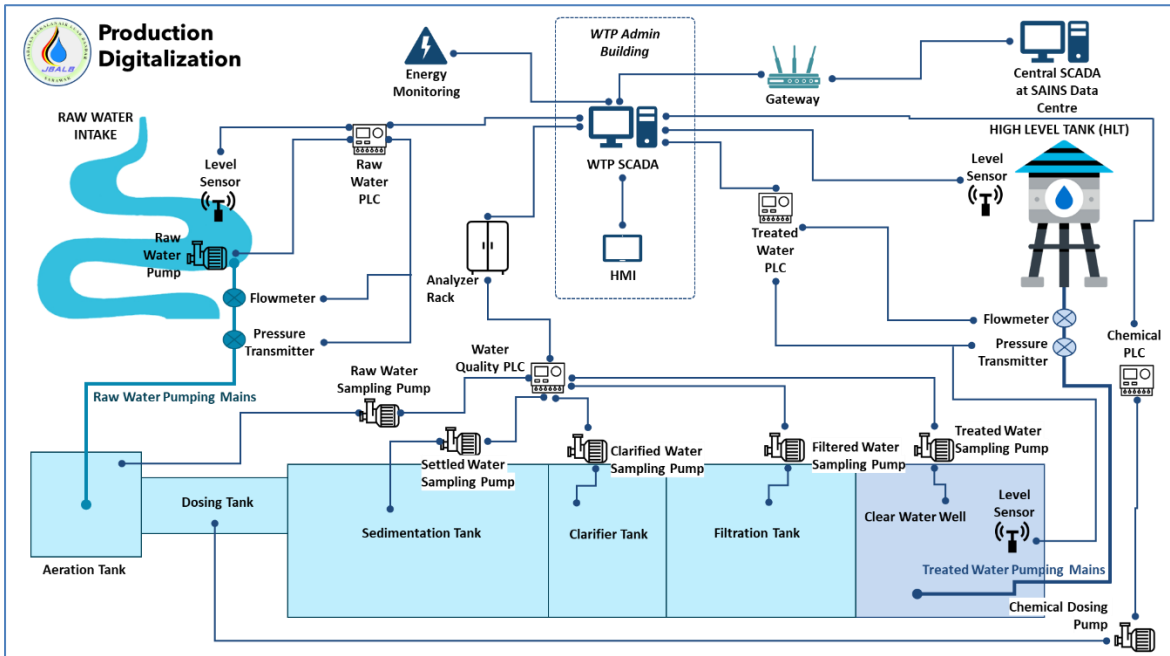

The data from WTP SCADA will then be transmitted to Central SCADA platform which is hosted at SAINS Data Centre. It is part of the entire Smart Water Supply System architecture which is also monitoring distribution pipelines and also digitization of drawings.

Why integration is crucial?

- a) To ensure continuity of JBALB water supply operation which leverages on digitalization features to be functional;
- b) To avoid wastages of digitalization development initiatives due to improper system and equipment maintenance;
- c) To ensure digitalization initiatives are up-to-date, properly maintained and serviced;
- d) To ensure continuous improvement to water quality services;
- e) To fully integrate other digitalization initiatives under Federal and State projects which needs to be incorporated into JBALB central water supply monitoring system;
- f) To ensure only qualified contractor with the required expertise is appointed to maintain the systems and equipment;
- g) To avoid inconsistencies on level of service and maintenance throughout divisions;
- h) To ensure no white elephant (no projects being abandoned after completion);
- i) To ensure digitalization initiatives are following to Sarawak government’s IT policy and guidelines; and
- j) To ensure digitalization initiatives implemented in JBALB are continuous, competent and relevant to the water industry standard and practices.

### 10.1 Production Digitalization

Consultant which was tasked to carry out design for projects involving construction or upgrading of any water supply facilities, must ensure that SCADA system works are provisioned in the tender document before the contract is being tendered. The system deployment can be procured through any procurement procedures required; however, the tender document must ensure that system integration is explicitly mentioned in the specification and requirements. The cost to carry out SCADA implementation works including the required system integration must be borne by the contract and budgeted prior to implementation of the project.

Before Contractor carried out installation of SCADA or any production monitoring system at JBALB WTP, a proposal with system architecture diagram must be produced first. Say, the SCADA system is different from JBALB Central SCADA system, the system architecture between JBALB HQ SCADA and WTP SCADA can be visualized in the following examples:

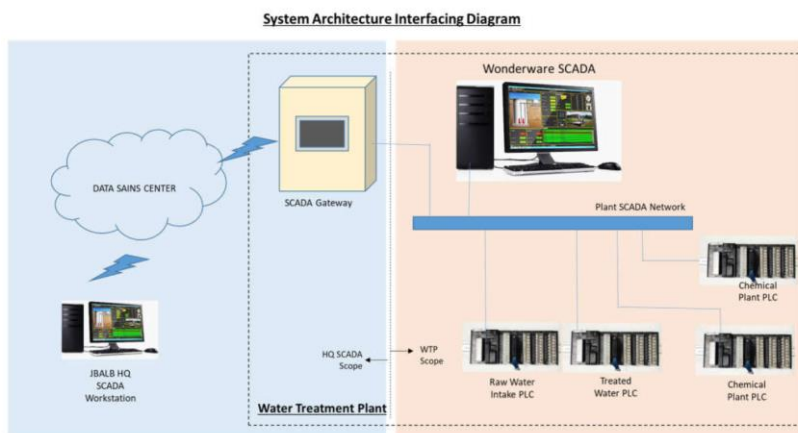

The scope of works for other WTP SCADA can range from installing PLC for Raw Water Intake, Treated Water Pumps, Chemical Plant and Admin Building (for Water Quality). Normally, the information will be read by the onsite SCADA workstation. The setup of JBALB Smart Water Supply System is as follows:

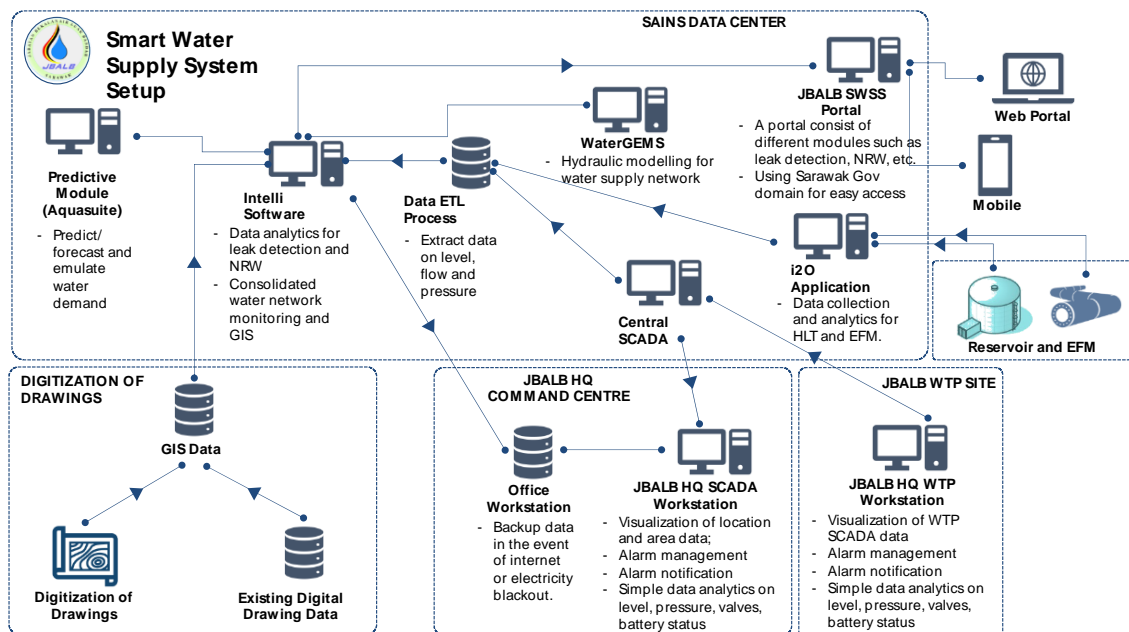

The detailed requirement of the proposed SCADA (production digitalization) are as follows:

No.	Particulars	Requirement
1	SCADA Architecture	<ul style="list-style-type: none"> <li>➤ SCADA architecture shall not be a proprietary ecosystem whereby all end-to-end solution consists of only single proprietary provider. It must consist of hardware, PLC and OPC software (OLE Process Control) which is SCADA;</li> <li>➤ SCADA system architecture and the required documents must be provided:                             <ul style="list-style-type: none"> <li>• Submitted in form of A3 drawing, signed by certified professional engineer;</li> <li>• Configuration shall show essential SCADA equipment to be provided for the entire plant;</li> <li>• Typical connection between outstations (O/S) and the master station;</li> <li>• Overall concept must be distributed control system – each individual section of the works responds automatically to local requirements and overall work requirements;</li> <li>• Provide list of equipment provided and network architecture;</li> <li>• Provide HMI interface screenshot (for every page);</li> <li>• Flowmeter and HLT within WTP shall form part of the SCADA;</li> <li>• Each PLCs IP address and port no;</li> <li>• ModBUS mapping addressing for the signal;</li> <li>• Each DPM communication setting, and a set of ModBUS addressing document;</li> <li>• Substation electrical single line diagram;</li> <li>• Proposed SCADA signals;</li> <li>• Proposed telco for network connectivity; and</li> <li>• Overall WTP process diagram</li> <li>• Can be remote monitoring or automated. If automated, shall provide sequence control functions for particular process areas at local control panels;</li> <li>• Loss of host computers and connection shall not impair process controls;</li> <li>• Any automation shall be functionally demonstrated before implementation. Range of automation shall be made clear with allowable customization to suit WTP operation.</li> <li>• Full operational data must be communicated and available at the Master Station;</li> <li>• Master station must be located at main control room of the WTP building;</li> <li>• O/S must be PLC-based, and connected to Master Station;</li> <li>• Must be fail-safe, designed for continuous 24 hours operation, with minimum maintenance. Failure of any part of the system</li> </ul> </li> </ul>

No.	Particulars	Requirement
		<p>shall be localized to that part only and shall not cause damage to the other parts of the system;</p> <ul style="list-style-type: none"> <li>• Non-critical component failures (such as HMI), shall not cause data corruption or loss of on-line functions;</li> </ul> <p>➤ For smaller WTPs (less than 5 MLD), SCADA architecture may not be needed. However, it must be designed to accommodate with at least a workstation (to connect to Sarawaknet’s system) and data server. Application shall be made to SSMU to install modem router for internet connection to connect to WORMS;</p> <p>➤ After T&amp;C, contractor is required to hand over the SCADA software installation CD, manual, network subscription (if applicable), together with the required documents to JBALB.</p>
2	Master Station SCADA Software and Equipment	<p>➤ Should the ICT equipment be provided by the project (such as Federal-funded and alternative funding projects), it shall be Windows based client/server system to operate between PLC based O/S and master station with specification as follows:</p> <ul style="list-style-type: none"> <li>• <b>SCADA software</b> <ul style="list-style-type: none"> <li>• Must use OPC client software.</li> </ul> </li> <li>• <b>Workstation</b> <ul style="list-style-type: none"> <li>• Min. one workstation;</li> <li>• Min. Windows 10 or latest;</li> <li>• Min. 4-core processor (Cache 2.50 GHz) or higher;</li> <li>• Min. 64GB DDR RAM;</li> <li>• Min. 5TB hybrid of SSD and HDD storage;</li> <li>• Graphic card with min. 8GB GDDR6 RAM;</li> <li>• Ethernet LAN 10/100/1000 Mbps;</li> <li>• Dual display monitor supports min. HD (1920x1080).                             <ul style="list-style-type: none"> <li>• <b>Local data server</b> <ul style="list-style-type: none"> <li>• Min. two data server – one as a backup;</li> <li>• Min. Microsoft SQL Server standard or equivalent. Must be latest update;</li> <li>• Min. 8-core processor (Cache 2.20 Ghz) or higher, or CPU utilization not exceeding 50% at peak load;</li> <li>• Min. 64GB RAM;</li> <li>• Min. 8 x 600 GB storage, or accommodate all current and future requirements plus 30% spare capacity;</li> <li>• Come with antivirus software.</li> </ul> </li> <li>• <b>HCI Switch</b> <ul style="list-style-type: none"> <li>• Min. 16 ports, 10GB uplink. Shall depend on number of O/S connections installed.</li> <li>• Servers and switches must be placed in a server rack at least 18U;</li> <li>• Specification shall be revised from time to time to suit for latest technology update;</li> </ul> </li> </ul> </li> </ul> </li> </ul>

No.	Particulars	Requirement
		<ul style="list-style-type: none"> <li>• Power fail-safe feature and save critical operation data in the event of shutdown or power outage;</li> <li>• <b>Uninterruptible Power Supply (UPS)</b> <ul style="list-style-type: none"> <li>• Total load hours of min. 4 hours</li> </ul> </li> <li>• <b>Human Machine Interface (HMI)</b> <ul style="list-style-type: none"> <li>• Must have HMI main screen with overall SCADA architecture;</li> </ul> </li> <li>• Include data for O/S – routine and historical data;</li> <li>• HMI must be touch screen, interactive and located at easily access area;</li> <li>• Master page of HMI consist of the following layout:           <ul style="list-style-type: none"> <li>• Sarawak Government and JBALB logo;</li> <li>• Name of WTP;</li> <li>• Title line – page title, number, time and date;</li> <li>• Banner area – for posting of alarms for operator’s immediate attention;</li> <li>• Dialogue line – for operator’s entry or action, typically at the bottom side;</li> <li>• Display area – remainder, largest portion of the screen for displays presentation;</li> <li>• Overall plant diagram showing the basic process groups;</li> <li>• Schematic of each processes;</li> <li>• Diagram of each grouping of major equipment;</li> <li>• An animated diagram for each process control/sequential loop;</li> <li>• Links to other pages;</li> <li>• No contractor’s/consultant’s/project’s names are allowed at HMI interface. Contractor should not link the system with any outside system without JBALB's approval.</li> <li>• Other pages can contain the following:               <ul style="list-style-type: none"> <li>• Process details and configuration c/w graphic display;</li> <li>• Animated display graphic;</li> <li>• Machines/equipment status – running, stopped, tripped, failed, available and not available;</li> <li>• Valves – open, closed, failed and available/not available;</li> <li>• Circuit breakers – open, closed and tripped.</li> </ul> </li> <li>• Alarm lists and event lists;</li> <li>• Historical data or data analysis.</li> </ul> </li> <li>• Alarm Management           <ul style="list-style-type: none"> <li>• Complete and comprehensive displaying, logging and storing alarms;</li> <li>• Shall be chronological order;</li> <li>• No action/acknowledgement shall be flashing;</li> <li>• Alarm cannot be disabled unless allowed;</li> <li>• Alarm history stored for up to 3 months.</li> </ul> </li> <li>• Event Management</li> </ul>

No.	Particulars	Requirement
		<ul style="list-style-type: none"> <li>• Capture and log events or status changes in the system including operator’s actions.</li> <li>• Event shall be stored for up to 3 months.</li> <li>• Trending data</li> <li>• Management reports</li> </ul>
3	Outstation Equipment	<ul style="list-style-type: none"> <li>• Must be <b>PLC-based</b>;</li> <li>• Must be as close as possible to the equipment to be monitored;</li> <li>• Shall be able to be calibrated locally or remotely;</li> <li>• <b>Instrument Panel</b> <ul style="list-style-type: none"> <li>• Height from the floor between 0.9 – 1.7 meter;</li> <li>• Self-draining steel plinth;</li> <li>• Come with hinged doors with lockable handles and removable access covers;</li> <li>• Cover must be dust-proof, vermin-proof, water-proof at least IP54 for indoor, IP65 for outdoor;</li> <li>• Doesn’t allow for condensation.</li> </ul> </li> <li>• <b>Panel Wiring</b> <ul style="list-style-type: none"> <li>• Shall be PVC insulated cable. Conform to electrical wiring standards</li> </ul> </li> <li>• <b>External Cabling and Wiring</b> <ul style="list-style-type: none"> <li>• Cables must run on walls, ceiling or other building structures, secured on cable trays or enclosed in wall or GI conduit appropriately;</li> <li>• Power cables and control cables must be segregated and installed on separate trays, secured on the walls and/or floor of the trenches, without hindering walking space. All cables must be segregated from other pipework, chemical lines and other services;</li> <li>• Conduit shall be of Class B hot dipped galvanized and screwed stainless steel type;</li> <li>• Other specifications to conform to electrical wiring standards;</li> <li>• After installation, must be tested, calibrated before being commissioned for use.</li> </ul> </li> </ul>
4	Program-mable Logic Controller (PLC)	<ul style="list-style-type: none"> <li>• Normally consist of CPUs, power supply, programming software, Ethernet and I/O interface system;</li> <li>• Can be remote monitoring or automation. For automated system, to perform control and data acquisition function for the automation processes of the plant;</li> <li>• Must be rugged, designed to operate reliably in conditions that expose to vibration, environmental challenges and electrical noise;</li> <li>• Sufficient to process the 140% required number of input and output (I/O) - 20% active spares + 20% for future I/O;</li> <li>• Below specification shall apply: <ul style="list-style-type: none"> <li>• <b>Instrument Panel and Wiring</b> <ul style="list-style-type: none"> <li>• Same as O/S conditions.</li> </ul> </li> <li>• <b>Uninterruptible Power Supply (UPS)</b></li> </ul> </li> </ul>

No.	Particulars	Requirement
		<ul style="list-style-type: none"> <li>• Total load hours of min. 4 hours;</li> <li>• Come with main fail and battery low contacts relayed to the PLC;</li> <li>• Shall be provided from a sensing circuit – adjustable to between 18-23 V with 0.5V hysteresis.</li> <li>• <b>Outdoor Transmitter Panel</b> <ul style="list-style-type: none"> <li>• Shall be of stainless steel, with plate thickness &gt; 2mm;</li> <li>• Panel with AC supply shall be equipped with 15A main switch, HRC fuses, earth leakage circuit breaker and lightning surge protector.</li> </ul> </li> <li>• <b>Networking</b> <ul style="list-style-type: none"> <li>• Shall be duplicated networking system;</li> <li>• Shall be connected to fibre optic backbone via an integrated TCP/IP network port using 100/1000 MBps ethernet switches;</li> <li>• Networking cable must be at least CAT5 and concealed in suitable conduits;</li> <li>• Networking cable conduit must be separated from power cable conduits;</li> <li>• Communication between O/S must be a set of LAN or WAN which is using ModBUS and TCP/IP protocol. No proprietary network ecosystem e.g LoRA, Sigfox etc is allowed;</li> <li>• In the event switches to be installed outside of master station, it must be installed in a switch rack;</li> <li>• No wireless connection is allowed between O/S PLC to master station with pumping equipment and other mechanical interference;</li> <li>• Wireless connection priority is using Wi-Fi or with booster. If VSAT/FWB is needed due to distance, SCSDU needs to be informed for application to install VSAT/FWB;</li> <li>• Wireless connection using radio links are highly discouraged. Application of wireless radio shall be registered with the MCMC and conform to MCMC guidelines and national legislation. Detailed cost for fees such as apparatus assignment fees must be provided.</li> </ul> </li> <li>• <b>I/O Modules</b> <ul style="list-style-type: none"> <li>• Each module shall have on-board diagnostics and able to perform hot-swapping functionalities. In the event of replacement, it shall not disrupt data transfer from the subsequent modules after the affected modules are removed;</li> <li>• Digital module – accept switch contacts, solid-state switches and high level logic, shall provide DC power to dry-field contacts or transistor switches, contact inputs shall be optically isolated to protect input circuits from transients and surges up to 200V RMS;</li> </ul> </li> </ul>

No.	Particulars	Requirement
		<ul style="list-style-type: none"> <li>• Analogue module – accept 4-20 mA DC, 1-5 V DC, thermocouple, RTD, 0-10 volts AC and pulse energy single ended and differential inputs from field mounted transmitters;</li> <li>• Analogue output modules shall convert data words into proportional, isolated 4 20mA DC analogue output signal to adjust set points of local process controllers, pump speeds, dose rates, valve positions, etc.</li> </ul>
5	Water Quality Analyzer	<ul style="list-style-type: none"> <li>• Water quality analyzer shall form part of the SCADA monitoring setup for water treatment plant construction or upgrading;</li> <li>• Parameters to be monitored shall comply with NDWQSP (Group I – Physical is compulsory, Group II – TDS, Chloride &amp; Aluminium are compulsory, Fluoride is compulsory for WTP with fluoride monitoring, while Manganese, Iron and Ammonia are encouraged);</li> <li>• Mandatory monitoring is raw, settled, filtered and treated water. Clarified water and sludge are encouraged;</li> <li>• Analyzer rack shall be formed part of the laboratory equipment in the laboratory room for the WTP;</li> <li>• It must be calibrated against the actual result during testing and commissioning;</li> <li>• Sampling pump must be installed at the appropriate location. For example, filtered water sampling pump must be located at the outlet pipe of the filter;</li> <li>• Sampling pumps must be installed at one duty and two standby. If they are different treatment packages/module for the plant, sampling must be done for every treatment module;</li> <li>• Sampling pumps must be installed at places which are easy to be accessed by the plant operator.               <ul style="list-style-type: none"> <li>• Sensor shall measure in the range of below:</li> <li>• All parameters must be time-stamped;</li> <li>• pH range -2 to 14.00 with sensitivity of +/- 0.01;</li> <li>• Turbidity range for raw water: 0-2000 NTU with sensitivity of +/- 0.1 NTU or +/-5% whichever is greater;</li> <li>• Turbidity range for settled, clarified, filtered and treated water: 0-50 NTU with accuracy of +/- 2% of reading, +/- 0.01 NTU (from 0-40 NTU), +/- 10% of reading (from 40-2000 NTU);</li> <li>• Res. Chlorine range for treated water: 0 – 20 mg/l with accuracy of 0.01 mg/l or +/- 1% of range, whichever is greater;</li> <li>• Res. Fluoride range for treated water: 0 – 10 mg/l with accuracy of 0.1 mg/l or +/- 10% of range, whichever is greater;</li> <li>• Color range shall be 0-100 with accuracy of 1 unit or +/- 10% of range, whichever is greater;</li> <li>• Res. Alum shall be 0-1 ppm with accuracy of 0.001 ppm or +/- 10% of range, whichever is greater;</li> </ul> </li> </ul>

No.	Particulars	Requirement
		<ul style="list-style-type: none"> <li>• Iron shall be 0-1ppm with accuracy of 0.001 ppm or +/- 10% of range, whichever is greater;</li> <li>• Manganese shall be 0-0.5 ppm with accuracy of 0.001 ppm or +/- 10% of range, whichever is greater;</li> <li>• Ammonia shall be 0-0.2 ppm with accuracy of 0.01 ppm or +/- 10% of range, whichever is greater;</li> <li>• TDS range for raw water: 0 – 1500 ppm with sensitivity of +/- 0.1 ppm or +/-5% whichever is greater;</li> <li>• Conductivity for raw and treated water: 0 – 1500 µs/cm with sensitivity of +10 µs/cm (must come with temperature sensor range 15-50°C);</li> <li>• Built-in electronics of the sensor shall be encapsulated with chemical resistance and mechanical strength rated IP66 for protection from moisture, humidity, dust and chemical intrusion. It must be wall-mounted on sturdy and secured stainless steel rack;</li> <li>• Must incorporate LCA – local charge analyzer;</li> <li>• To incorporate VSD type sampling pumps (if possible);</li> </ul>
6	Water Resource Monitoring	<ul style="list-style-type: none"> <li>• Water resource monitoring shall be installed at appropriate location. To minimize development capital costs and maintenance, data loggers must be battery-powered with solar charging capabilities with specification as below: <ul style="list-style-type: none"> <li>• Low power consumption: Min. 3.6 V lithium lasts min. 2 years;</li> <li>• Data memory of min. 8 MB flash EPROM;</li> <li>• Able to record min. 100,000 events at 1 second resolution;</li> <li>• Communication using RS232 port/USB/ethernet and Wi-Fi;</li> <li>• Environment range: -40 to +70°C;</li> <li>• Other requirements to follow DID HP 32 standard;</li> <li>• Must connect to central SCADA. Data must be easily captured for use by central SCADA through API with the data logger's network.</li> </ul> </li> <li>• The locality shall not duplicate location of existing DID and NREB loggers. In the event existing loggers are available, need to liaise with DID and NREB for data integration;</li> <li>• Water quality for water resource must comply to the MoH standard</li> <li>• Mandatory monitoring is salinity, conductivity, turbidity, pH, weather condition, water condition and water appearance;</li> <li>• Sensor shall measure in the range of below (some are not mandatory monitoring, but must follow the range specified below.</li> <li>• All parameters must be time-stamped; <ul style="list-style-type: none"> <li>• Salinity range: 0 – 30 ppt with sensitivity of +/- 0.1 ppt;</li> <li>• Conductivity for raw and treated water: 0 – 1500 µs/cm with sensitivity of +10 µs/cm (must come with temperature sensor range 15-50°C);</li> <li>• Turbidity range: : 0-2000 NTU with sensitivity of +/- 0.1 NTU or +/- 5% whichever is greater;</li> </ul> </li> </ul>

No.	Particulars	Requirement																																																																																							
		<ul style="list-style-type: none"> <li>• pH range: -2 to 14.00 with sensitivity of +/- 0.01;</li> <li>• DO range: 0 to 10.00 mg/L with sensitivity of +/-0.01 mg/L;</li> <li>• DO % range: 0 to 100% with sensitivity of 0.1%;</li> <li>• Weather condition to be captured e.g. rainy;</li> <li>• Water condition to be captured: low tide, slow flow, high tide;</li> <li>• Water appearance to be captured: turbid, clear, normal;</li> <li>• BOD range: 0 – 100 mg/L with sensitivity of 0.1 mg/L;</li> <li>• COD range: 0 – 100 mg/L with sensitivity of 0.1 mg/L;</li> <li>• TSS range: 0 – 300 mg/L with sensitivity of 0.1 mg/L;</li> <li>• Ammoniacal Nitrogen range: 0 – 5 mg/L with sensitivity of 0.01 mg/L;</li> <li>• Nitrate range: 0 – 7 mg/L with sensitivity of 0.01 mg/L;</li> <li>• Phosphate range: 0 – 0.5 mg/L with sensitivity of 0.01 mg/L.</li> <li>• Must allow for manual sampling to carry out manual and laboratory tests such as for FCC and TCC.</li> </ul>																																																																																							
7	Signals	<ul style="list-style-type: none"> <li>• Signals must follow the following standards:</li> </ul> <table border="1" data-bbox="639 898 1469 1906"> <thead> <tr> <th data-bbox="646 898 847 920">Location</th> <th data-bbox="847 898 1273 920">Signal</th> <th data-bbox="1273 898 1463 920">Signal Type</th> </tr> </thead> <tbody> <tr> <td data-bbox="646 920 847 1077" rowspan="5">Raw Water Intake</td> <td data-bbox="847 920 1273 943">River Water Level</td> <td data-bbox="1273 920 1463 943">AI</td> </tr> <tr> <td data-bbox="847 943 1273 965">Raw Water Pump Running Status</td> <td data-bbox="1273 943 1463 965">DI</td> </tr> <tr> <td data-bbox="847 965 1273 987">Raw Water Pump Tripped Status</td> <td data-bbox="1273 965 1463 987">DI</td> </tr> <tr> <td data-bbox="847 987 1273 1010">Raw Water Flowrate</td> <td data-bbox="1273 987 1463 1010">AI</td> </tr> <tr> <td data-bbox="847 1010 1273 1032">Raw Water Totalizer</td> <td data-bbox="1273 1010 1463 1032">AI (Double Word)</td> </tr> <tr> <td data-bbox="646 1032 847 1055">Raw Water Delivery Pressure</td> <td data-bbox="847 1032 1273 1055"></td> <td data-bbox="1273 1032 1463 1055">AI</td> </tr> <tr> <td data-bbox="646 1055 847 1122" rowspan="2">Chemical Plant (Dosing)</td> <td data-bbox="847 1055 1273 1077">Chemical Dosing Pump Running (All)</td> <td data-bbox="1273 1055 1463 1077">DI</td> </tr> <tr> <td data-bbox="847 1077 1273 1099">Chemical Dosing Pump Tripped (All)</td> <td data-bbox="1273 1077 1463 1099">DI</td> </tr> <tr> <td data-bbox="646 1099 847 1301" rowspan="6">Treated Water Pumping</td> <td data-bbox="847 1099 1273 1122">Treated Water Pump Running Status</td> <td data-bbox="1273 1099 1463 1122">DI</td> </tr> <tr> <td data-bbox="847 1122 1273 1144">Treated Water Pump Tripped Status</td> <td data-bbox="1273 1122 1463 1144">DI</td> </tr> <tr> <td data-bbox="847 1144 1273 1167">Clear Water Tank Water Level</td> <td data-bbox="1273 1144 1463 1167">AI</td> </tr> <tr> <td data-bbox="847 1167 1273 1189">Backwash Tank Water Level</td> <td data-bbox="1273 1167 1463 1189">AI</td> </tr> <tr> <td data-bbox="847 1189 1273 1211">Treated Water Flowrate</td> <td data-bbox="1273 1189 1463 1211">AI</td> </tr> <tr> <td data-bbox="847 1211 1273 1234">Treated Water Totalizer</td> <td data-bbox="1273 1211 1463 1234">AI (Double Word)</td> </tr> <tr> <td data-bbox="646 1234 847 1256">Treated Water Delivery Pressure</td> <td data-bbox="847 1234 1273 1256"></td> <td data-bbox="1273 1234 1463 1256">AI</td> </tr> <tr> <td data-bbox="646 1256 847 1704" rowspan="13">Admin Building/Lab (Water Quality)</td> <td data-bbox="847 1256 1273 1279">Raw Water Turbidity</td> <td data-bbox="1273 1256 1463 1279">AI</td> </tr> <tr> <td data-bbox="847 1279 1273 1301">Raw Water pH</td> <td data-bbox="1273 1279 1463 1301">AI</td> </tr> <tr> <td data-bbox="847 1301 1273 1323">Raw Water Colour</td> <td data-bbox="1273 1301 1463 1323">AI</td> </tr> <tr> <td data-bbox="847 1323 1273 1346">Settled Water Turbidity</td> <td data-bbox="1273 1323 1463 1346">AI</td> </tr> <tr> <td data-bbox="847 1346 1273 1368">Settled Water pH</td> <td data-bbox="1273 1346 1463 1368">AI</td> </tr> <tr> <td data-bbox="847 1368 1273 1391">Filtered Water Turbidity</td> <td data-bbox="1273 1368 1463 1391">AI</td> </tr> <tr> <td data-bbox="847 1391 1273 1413">Filtered Water pH</td> <td data-bbox="1273 1391 1463 1413">AI</td> </tr> <tr> <td data-bbox="847 1413 1273 1435">Clarifier Water Colour</td> <td data-bbox="1273 1413 1463 1435">AI</td> </tr> <tr> <td data-bbox="847 1435 1273 1458">Treated Water Turbidity</td> <td data-bbox="1273 1435 1463 1458">AI</td> </tr> <tr> <td data-bbox="847 1458 1273 1480">Treated Water pH</td> <td data-bbox="1273 1458 1463 1480">AI</td> </tr> <tr> <td data-bbox="847 1480 1273 1503">Treated Water Residual Fluoride</td> <td data-bbox="1273 1480 1463 1503">AI</td> </tr> <tr> <td data-bbox="847 1503 1273 1525">Treated Water Residual Chlorine</td> <td data-bbox="1273 1503 1463 1525">AI</td> </tr> <tr> <td data-bbox="847 1525 1273 1547">Treated Water Residual Alum</td> <td data-bbox="1273 1525 1463 1547">AI</td> </tr> <tr> <td data-bbox="646 1547 847 1570">Treated Water Colour</td> <td data-bbox="847 1547 1273 1570"></td> <td data-bbox="1273 1547 1463 1570">AI</td> </tr> <tr> <td data-bbox="646 1570 847 1592">High Level Tank Water Level (if any)</td> <td data-bbox="847 1570 1273 1592"></td> <td data-bbox="1273 1570 1463 1592">AI</td> </tr> <tr> <td data-bbox="646 1592 847 1615" rowspan="6">LV Substation</td> <td data-bbox="847 1592 1273 1615">Incoming Total Power</td> <td data-bbox="1273 1592 1463 1615">D</td> </tr> <tr> <td data-bbox="847 1615 1273 1637">Incoming Energy</td> <td data-bbox="1273 1615 1463 1637">D</td> </tr> <tr> <td data-bbox="847 1637 1273 1659">Incoming Voltage</td> <td data-bbox="1273 1637 1463 1659">D</td> </tr> <tr> <td data-bbox="847 1659 1273 1682">Incoming Current</td> <td data-bbox="1273 1659 1463 1682">D</td> </tr> <tr> <td data-bbox="847 1682 1273 1704">Incoming pF</td> <td data-bbox="1273 1682 1463 1704">D</td> </tr> <tr> <td data-bbox="847 1704 1273 1727">Incoming Reactive Power</td> <td data-bbox="1273 1704 1463 1727">D</td> </tr> <tr> <td data-bbox="646 1727 847 1749">Incoming Apparent Power</td> <td data-bbox="847 1727 1273 1749"></td> <td data-bbox="1273 1727 1463 1749">D</td> </tr> </tbody> </table>	Location	Signal	Signal Type	Raw Water Intake	River Water Level	AI	Raw Water Pump Running Status	DI	Raw Water Pump Tripped Status	DI	Raw Water Flowrate	AI	Raw Water Totalizer	AI (Double Word)	Raw Water Delivery Pressure		AI	Chemical Plant (Dosing)	Chemical Dosing Pump Running (All)	DI	Chemical Dosing Pump Tripped (All)	DI	Treated Water Pumping	Treated Water Pump Running Status	DI	Treated Water Pump Tripped Status	DI	Clear Water Tank Water Level	AI	Backwash Tank Water Level	AI	Treated Water Flowrate	AI	Treated Water Totalizer	AI (Double Word)	Treated Water Delivery Pressure		AI	Admin Building/Lab (Water Quality)	Raw Water Turbidity	AI	Raw Water pH	AI	Raw Water Colour	AI	Settled Water Turbidity	AI	Settled Water pH	AI	Filtered Water Turbidity	AI	Filtered Water pH	AI	Clarifier Water Colour	AI	Treated Water Turbidity	AI	Treated Water pH	AI	Treated Water Residual Fluoride	AI	Treated Water Residual Chlorine	AI	Treated Water Residual Alum	AI	Treated Water Colour		AI	High Level Tank Water Level (if any)		AI	LV Substation	Incoming Total Power	D	Incoming Energy	D	Incoming Voltage	D	Incoming Current	D	Incoming pF	D	Incoming Reactive Power	D	Incoming Apparent Power		D
Location	Signal	Signal Type																																																																																							
Raw Water Intake	River Water Level	AI																																																																																							
	Raw Water Pump Running Status	DI																																																																																							
	Raw Water Pump Tripped Status	DI																																																																																							
	Raw Water Flowrate	AI																																																																																							
	Raw Water Totalizer	AI (Double Word)																																																																																							
Raw Water Delivery Pressure		AI																																																																																							
Chemical Plant (Dosing)	Chemical Dosing Pump Running (All)	DI																																																																																							
	Chemical Dosing Pump Tripped (All)	DI																																																																																							
Treated Water Pumping	Treated Water Pump Running Status	DI																																																																																							
	Treated Water Pump Tripped Status	DI																																																																																							
	Clear Water Tank Water Level	AI																																																																																							
	Backwash Tank Water Level	AI																																																																																							
	Treated Water Flowrate	AI																																																																																							
	Treated Water Totalizer	AI (Double Word)																																																																																							
Treated Water Delivery Pressure		AI																																																																																							
Admin Building/Lab (Water Quality)	Raw Water Turbidity	AI																																																																																							
	Raw Water pH	AI																																																																																							
	Raw Water Colour	AI																																																																																							
	Settled Water Turbidity	AI																																																																																							
	Settled Water pH	AI																																																																																							
	Filtered Water Turbidity	AI																																																																																							
	Filtered Water pH	AI																																																																																							
	Clarifier Water Colour	AI																																																																																							
	Treated Water Turbidity	AI																																																																																							
	Treated Water pH	AI																																																																																							
	Treated Water Residual Fluoride	AI																																																																																							
	Treated Water Residual Chlorine	AI																																																																																							
	Treated Water Residual Alum	AI																																																																																							
Treated Water Colour		AI																																																																																							
High Level Tank Water Level (if any)		AI																																																																																							
LV Substation	Incoming Total Power	D																																																																																							
	Incoming Energy	D																																																																																							
	Incoming Voltage	D																																																																																							
	Incoming Current	D																																																																																							
	Incoming pF	D																																																																																							
	Incoming Reactive Power	D																																																																																							
Incoming Apparent Power		D																																																																																							

No.	Particulars	Requirement																																	
		<table border="1"> <thead> <tr> <th data-bbox="644 241 842 271">Location</th> <th data-bbox="842 241 1273 271">Signal</th> <th data-bbox="1273 241 1476 271">Signal Type</th> </tr> </thead> <tbody> <tr> <td data-bbox="644 271 842 300">Treated Water Pumping</td> <td data-bbox="842 271 1273 300">Pump Running Status</td> <td data-bbox="1273 271 1476 300">DI</td> </tr> <tr> <td></td> <td data-bbox="842 300 1273 329">Pump Tripped Status</td> <td data-bbox="1273 300 1476 329">DI</td> </tr> <tr> <td></td> <td data-bbox="842 329 1273 358">Suction Tank Water Level</td> <td data-bbox="1273 329 1476 358">AI</td> </tr> <tr> <td></td> <td data-bbox="842 358 1273 387">Reservoir Tank Water Level</td> <td data-bbox="1273 358 1476 387">AI</td> </tr> <tr> <td></td> <td data-bbox="842 387 1273 416">Reservoir Tank Outlet Flowrate</td> <td data-bbox="1273 387 1476 416">AI</td> </tr> <tr> <td></td> <td data-bbox="842 416 1273 445">Reservoir Tank Outlet Totalizer</td> <td data-bbox="1273 416 1476 445">AI (Double Word)</td> </tr> <tr> <td></td> <td data-bbox="842 445 1273 474">Treated Water Pumping Flowrate</td> <td data-bbox="1273 445 1476 474">AI</td> </tr> <tr> <td></td> <td data-bbox="842 474 1273 504">Treated Water Pumping Totalizer</td> <td data-bbox="1273 474 1476 504">AI (Double Word)</td> </tr> <tr> <td></td> <td data-bbox="842 504 1273 555">Treated Water Delivery Pressure (Outgoing Pumping Pressure)</td> <td data-bbox="1273 504 1476 555">AI</td> </tr> <tr> <td></td> <td data-bbox="842 555 1273 584">VSD Speed (if applicable)</td> <td data-bbox="1273 555 1476 584">AI</td> </tr> </tbody> </table>	Location	Signal	Signal Type	Treated Water Pumping	Pump Running Status	DI		Pump Tripped Status	DI		Suction Tank Water Level	AI		Reservoir Tank Water Level	AI		Reservoir Tank Outlet Flowrate	AI		Reservoir Tank Outlet Totalizer	AI (Double Word)		Treated Water Pumping Flowrate	AI		Treated Water Pumping Totalizer	AI (Double Word)		Treated Water Delivery Pressure (Outgoing Pumping Pressure)	AI		VSD Speed (if applicable)	AI
Location	Signal	Signal Type																																	
Treated Water Pumping	Pump Running Status	DI																																	
	Pump Tripped Status	DI																																	
	Suction Tank Water Level	AI																																	
	Reservoir Tank Water Level	AI																																	
	Reservoir Tank Outlet Flowrate	AI																																	
	Reservoir Tank Outlet Totalizer	AI (Double Word)																																	
	Treated Water Pumping Flowrate	AI																																	
	Treated Water Pumping Totalizer	AI (Double Word)																																	
	Treated Water Delivery Pressure (Outgoing Pumping Pressure)	AI																																	
	VSD Speed (if applicable)	AI																																	
8	Chemical Dosing	<ul style="list-style-type: none"> <li>• Dosing pumps must be formed as part of the SCADA system;</li> <li>• Dosing pumps must be installed at the designated dosing tank, for both pre-treatment and treatment stages, except for chlorine at clear water well and booster station’s suction tank (if applicable);</li> <li>• Dosing pumps must be installed at one duty and two standby. If they are different treatment packages/module for the plant, dosing must be monitored for every treatment module;</li> <li>• Dosing pumps must be installed at places which are easy to be accessed by the plant operator;</li> <li>• Must monitor status for start, stop, tripped, failed, or not available;</li> <li>• Usage of auto dosing modules such as stream current monitoring (SCM) is mandatory for raw water with highly fluctuating quality and volume, encouraged for others. However, it must have ease of maintenance, and effective.</li> </ul>																																	
9	Flowmeter	<ul style="list-style-type: none"> <li>• Shall be battery-powered type. For flowmeters to measure raw and treated within WTP, must be connected to power cable. Battery must be lithium battery, last not less than 6 years, come with warranty of at least 2 years and designed to withstand up to 60°C;</li> <li>• Can be either electromagnetic or ultrasonic;</li> <li>• Accuracy must be equal or better than 0.40% of actual lamina flow from full scale flow rate to 50% flow rate increasing progressively to maximum of 5% of the actual flow at 10% flow rate;</li> <li>• Flowmeter to measure raw and treated water within WTP must form part of the SCADA system.</li> </ul>																																	
10	Transmitter/ Signal Converter (For Flowmeter)	<ul style="list-style-type: none"> <li>• Signal cable must be originally manufactured for type of O/S to be installed, and not through third party contractor/supplier;</li> <li>• Signal cable must be able to withstand under water.</li> <li>• Transmitter/signal converter for flowmeter shall be microprocessor-based type with function for adjustment, self-diagnostic and error reporting. It shall incorporate hardware and software protection;</li> <li>• Shall enable add on for future communication module;</li> <li>• Shall be equipped with comprehensive display minimum of the following: <ul style="list-style-type: none"> <li>• Flow rate;</li> <li>• Velocity;</li> </ul> </li> </ul>																																	

No.	Particulars	Requirement
		<ul style="list-style-type: none"> <li>• Totalizer (all forward flow, reverse flow, and net flow);</li> <li>• Volume delivered based on time of day or flow rates or a combination;</li> <li>• Date &amp; time;</li> <li>• Selectable volume and flow rate unit (MLD, M3/h, GPM etc.).</li> <li>• Must have built-in data logger or data backup system to ensure no loss of historical data and parameters.</li> </ul>
11	Energy Monitoring	<ul style="list-style-type: none"> <li>• Shall provide to monitor total plant energy usage, where it can link back to IOT gateway and forward the information to master station at real time;</li> <li>• Monitor incoming MSB for WTP, capture hourly energy consumption, energy parameters such as 3-phase real power, power factor, current, voltage, etc.;</li> <li>• Modular form provided for flexible installation and configuration. It must form part of the proposed MSB;</li> <li>• User can interact through LCD display and buttons. LCD display must be high resolution;</li> <li>• Communication protocol must be ModBUS RTU;</li> <li>• Connectors between sensors to the sensing module should be flexible connector such as RJ12;</li> <li>• Modules must be lockable, IP68 rated and able to be close/open by users;</li> <li>• Cables within and between modules shall be managed properly through cable management system and labelling;</li> <li>• System shall be able to monitor several circuits via a single current measurement module, a single voltage measurement point for few outgoing circuits and outgoing current module or as user required.</li> </ul>
12	CCTV Monitoring	<ul style="list-style-type: none"> <li>• In the event of installation of CCTV, it is required to obtain approval from <i>Unit Keselamatan dan Penguatkuasaan Sarawak</i> (UKPS) before implementation;</li> <li>• Due to heavy utilization of bandwidth by CCTV, intranet and internet connection must be standalone and not shared with SCADA or IOTs installed at WTPs or BPSs;</li> <li>• In the event of offsite monitoring, LMIC must be utilizing unlimited data high fibre broadband or FWB. Usage of LMIC with capped data are not allowed. For areas with only VSAT available, CCTV should not be implemented to minimize heavy bandwidth usage.</li> </ul>

## 10.2 Distribution Digitalization

Consultant which was tasked to carry out design for projects involving construction or upgrading of any water supply facilities for distribution, must ensure that all telemetry installed must come with telemetry backend systems, and are provisioned in the tender document before the contract is being tendered. The system deployment can be procured through any

procurement procedures required; however, the tender document must ensure that system integration is explicitly mentioned in the specification and requirements. The cost to carry out telemetry implementation works including the required system integration must be borne by the contract and budgeted prior to implementation of the project.

Telemetries integration should follow the following architecture.

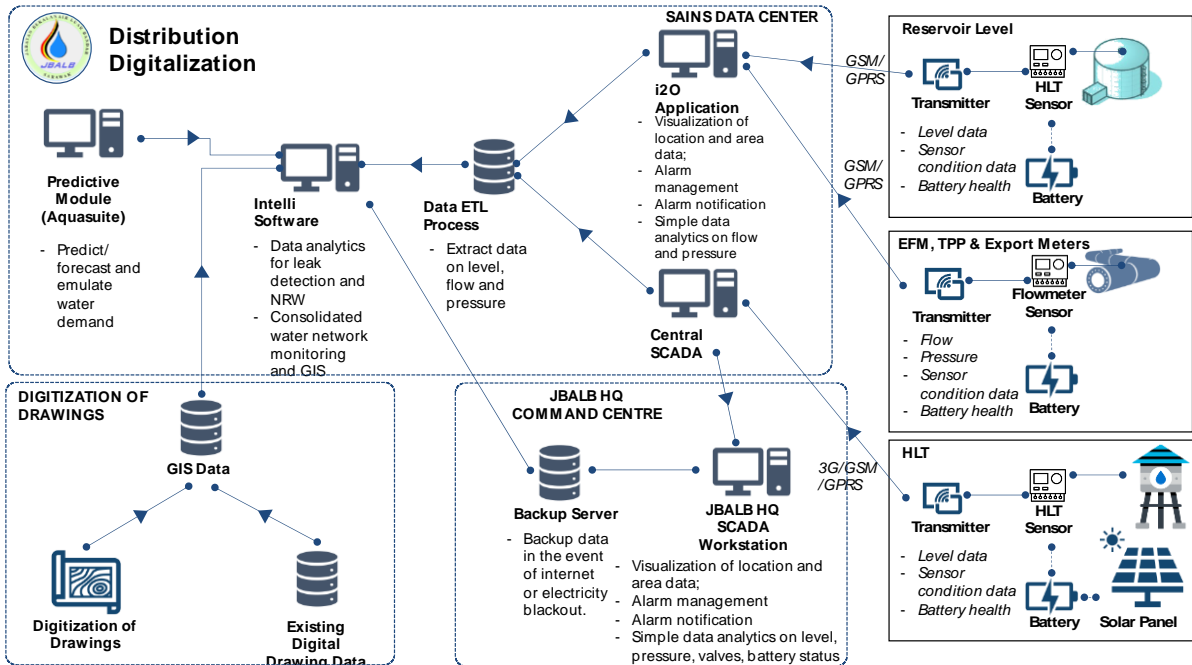

The detailed requirement for telemetries (distribution digitalization) are as follows:

No.	Particulars	Requirement
1	Data Loggers	<ul style="list-style-type: none"> <li>• Shall be battery-powered type. Battery must be lithium battery, last not less than 6 years, come with warranty of at least 2 years and designed to withstand up to 60°C;</li> <li>• Data logger shall come with the following components: data logger, connection cables, software interface and SIM card;</li> <li>• Must be compact, robust, reliable and light weight;</li> <li>• Minimum memory of 4MB for non-volatile data storage up to a year. Must ensure no data loss can occur from power interruption;</li> <li>• Support GSM/GPRS quadband data, SMS network or any equivalent network. No proprietary network protocol is allowed;</li> <li>• Data transmission shall be 15 mins, 30 mins, 1 hour, 1 day, 1 week or 1 month at programmable date and time;</li> <li>• Shall have alarm dial out setting for each channel;</li> <li>• Shall come with internal or external antenna with 5m or 10m cable;</li> <li>• Must be IP68 certified and installed in an underground chamber;</li> <li>• Subscription during project of at least 36 months with GPS/GPRS/3G/4G or compatible network connection;</li> </ul>

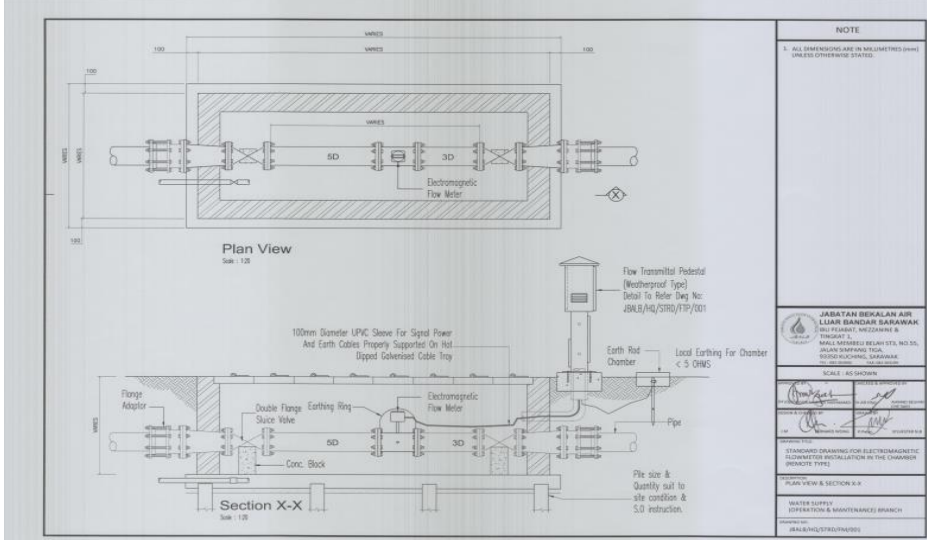
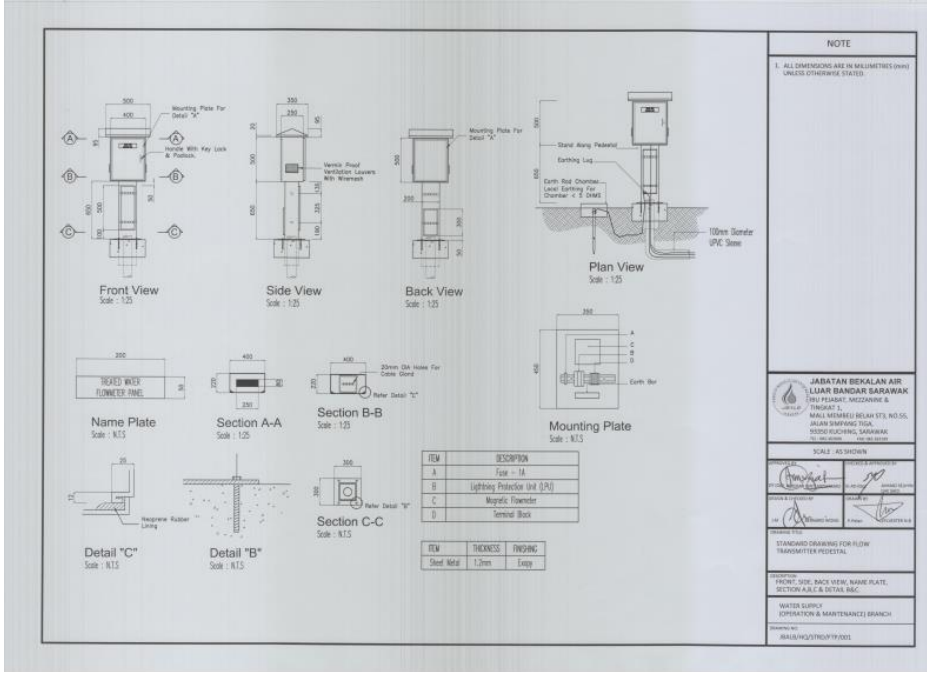
No.	Particulars	Requirement
2	Chamber	<ul style="list-style-type: none"> <li>• Scope for system integration between IOTs and SWSS shall be included as part of the project implementation for the HLT IOTs.</li> <li>• Chamber shall be built of brick wall or concrete wall according to JBALB standard drawing as per drawings attached.</li> </ul>  <p><i>JBALB Standard Drawing for Electromagnetic Flowmeter Installation in the Chamber (JBALB/HQ/STRD/FM/001)</i></p>  <p><i>JBALB Standard Drawing for Flow Transmitter Pedestal (JBALB/HQ/STRD/FTP/001)</i></p>
3	Flowmeter	<ul style="list-style-type: none"> <li>• Can be either electromagnetic or ultrasonic;</li> <li>• Must have SWA approval prior to installation;</li> <li>• Accuracy must be equal or better than 0.40% of actual lamina flow from full scale flow rate to 50% flow rate increasing progressively to maximum of 5% of the actual flow at 10% flow rate;</li> </ul>

No.	Particulars	Requirement
		<ul style="list-style-type: none"> <li>• Must be located appropriately to measure flow of the intended area to be monitored;</li> <li>• Shall be remote type (detachable from converter) and can be connected to converter via IP68 cable and connectors with maximum length of 30m;</li> <li>• Shall be rated IP68;</li> <li>• Shall be free from external influences which can affect accuracy such as magnetic fields, electromagnetic fields etc.;</li> <li>• Designed full or contoured bore with range of diameters from 25mm to 1500mm;</li> <li>• Shall be flanged design and be rated to handle pressure of up to 16 Bar;</li> <li>• Body shall be made of carbon steel and electrodes are from stainless steel (AISI 316);</li> <li>• Lining should be suitable for potable water such as polypropylene and ebonite;</li> <li>• Ground termination must be provided;</li> <li>• Accuracy shall be 0.25% or better;</li> <li>• Able to measure forward flow, reverse flow and empty flow.</li> </ul>
4	Level Sensors/ Detectors	<ul style="list-style-type: none"> <li>• Level can be measured either using level detector or hydrostatic;</li> <li>• For level detector, level electrodes shall be made of stainless steel (Grade 316) encapsulated in heat shrinkable tubing down to 75mm from end of the electrode. Electrode heads shall be manufactured from reinforced glass fibre or similar corrosion proof insulated material and IP65-rated;</li> <li>• For hydrostatic, it must be built by means of gauge pressure transmitter which consist of 1-inch diameter direct tapping complete with GI pipe or copper tubing and isolating corks. Pressure transmitter must be installed at the outlet pipe and ground base of the HLT/reservoir. Level can be measured from deducting pressure in meter with the height of HLT/reservoir from the outlet at ground base;</li> <li>• The following signal must be able to be monitored:               <ul style="list-style-type: none"> <li>• Water level;</li> <li>• Pressure;</li> <li>• Flow rate (if any);</li> <li>• Suction valves;</li> <li>• Deliver valves;</li> <li>• Battery status;</li> <li>• Solar system health.</li> </ul> </li> <li>• It is highly encouraged to incorporate inlet and outlet pressure and flow monitoring, which the system can be combined within the level sensing equipment panel.</li> </ul>

### 10.3 Consumption Digitalization

As for consumption digitalization, installed smart water meters (SWM) must be borne by the contract including system integration and network configuration/study. Diagram below shows

architecture of SWMs which needs to be complied by the contract either using radio frequency (RF) or NB-IOT.

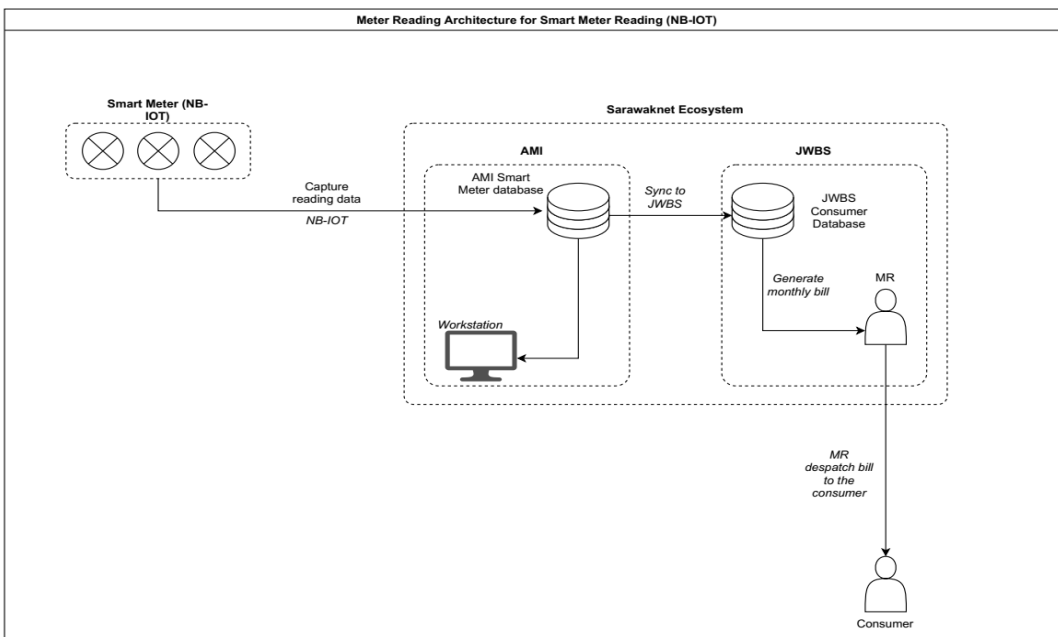
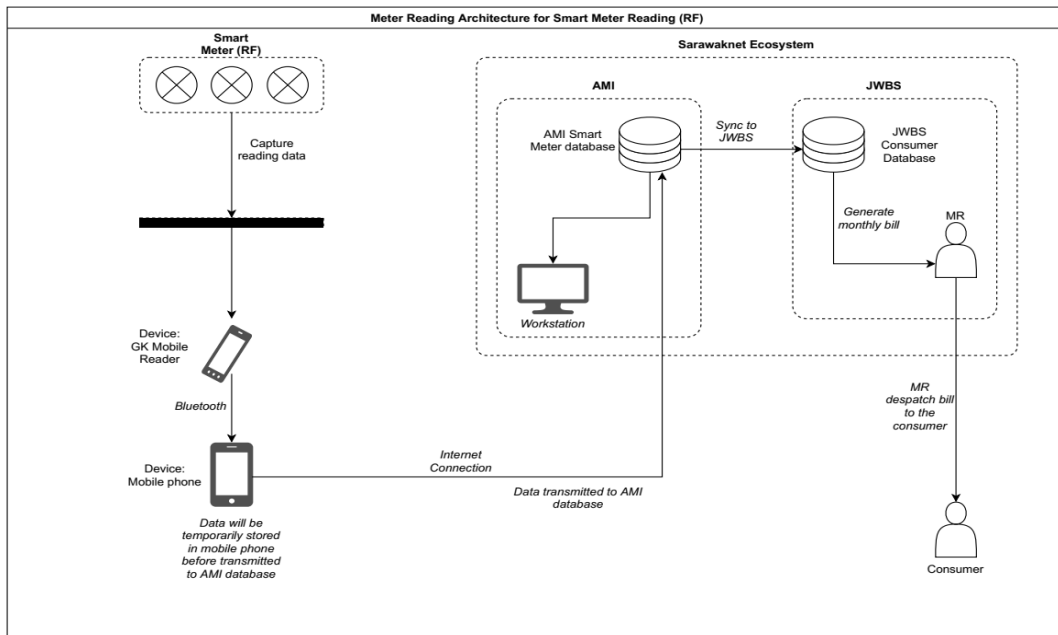

Below are the details of requirements for the SWMs:

No.	Particulars	Requirement
1	Smart Water Meters & Data Concentrator	<ul style="list-style-type: none"> <li>• Must be approved by SWA prior to implementation;</li> <li>• Shall be battery-powered type. Battery must be lithium battery or equivalent, last not less than 5 years, come with warranty of at least 2 years and designed to withstand up to 60°C;</li> <li>• It must come with a local mechanical meter for counter checking/calibration or with equivalent mechanism;</li> </ul>

No.	Particulars	Requirement
		<ul style="list-style-type: none"> <li>• Must be able to withstand physical and environmental resistance;</li> <li>• Must be compact, robust, reliable and light weight;</li> <li>• Minimum memory of 4MB for non-volatile data storage up to a year. Must ensure no data loss can occur from power interruption;</li> <li>• Support NB-IOT, RF or any equivalent network. No free band (such as infrared signals) and proprietary ecosystem is allowed;</li> <li>• For RF, network frequency must be dedicated licensed signals with MCMC. JBALB shall not be tasked to borne any payment of licensing and assignment fees to MCMC, as it shall be fully borne by the suppliers;</li> <li>• Data transmission shall be 15 mins, 30 mins, 1 hour, 1 day, 1 week or 1 month at programmable date and time;</li> <li>• Must be IP68 certified and installed at a meter stand (refer JBALB standard drawing);</li> <li>• Installation shall not cause existing meter stand or communication pipes to be realigned;</li> <li>• For RF, must come with handheld meter reading device using a certified, waived of any MCMC annual fees and reliable radio frequency;</li> <li>• Subscription during project of at least 36 months with NB-IOT, RF or compatible network connection.</li> <li>• Data concentrator must not allow storage of data for more than 1 month. All data must only be temporarily stored in the data concentrator and should be protected from risk of hacking.</li> </ul>
2	Software for SWMs	<ul style="list-style-type: none"> <li>• Smart meter must be able to transfer data through API with JBALB Advanced Meter Infrastructure (AMI) platform. JBALB CCD to liaise with SAINS on the device integration;</li> <li>• Web-based development for consumption and monitoring billing are not allowed;</li> <li>• Installation of servers and other hardware for data acquisition are not allowed (except federal-funded. Even with federal-funded projects, efforts must be made to utilize the current JBALB co-located server). Database is to make full use of JBALB AMI platform;</li> <li>• GPS info must be captured prior to installation.</li> <li>• Backend software for SWMs is allowed, however, data must be stored and managed and JBALB co-located server at SAINS data center.</li> </ul>

## 10.4 System Integration

For integration works to JBALB Central SCADA system, the SCADA gateway will be installed at the WTP, polling the information from all the PLCs and LV Substation Digital Power Meter (if applicable). This information will be displayed at the local SCADA gateway touch screen or HMI (Human Machine Interface). At the same time, the data will also be sent to JBALB HQ Central SCADA for analysis.

The Contractor for the other SCADA project shall provide the network within the WTP. All PLCs shall be interconnected and make available network port at WTP Admin Building office, where the WTP SCADA workstation are located. Please ensure that PLCs are complying to MODBUS TCP protocol. Some PLCs such as OMRON are not using MODBUS TCP Protocol, but instead, using IP address. This is also acceptable. Other proprietary PLCs with proprietary communication protocol (which are part of suite software and ecosystem) are not allowed to be used.

JBALB HQ SCADA communication gateway will be installed at the same location near the WTP SCADA workstation and sharing the plant SCADA MODBUS TCP network. For this interconnection to work, the WTP SCADA contractor shall provide network information, such as all equipment IP address, system architecture and detailed data mapping addressing.

The interconnection requirement for Digital Power Meter (DPM) Interfacing are as follows:

- a) DPM need to be installed at the WTP main switch board (MSB) incoming and provide the energy consumption for the plant;
- b) DPM shall come with Ethernet communication port and support MODBUS TCP protocol;
- c) It shall be Schneider PM5320 or equivalent model, which provide the standard address mapping for the parameters.

WTP SCADA Contractor shall include the following signals, but not limited to:

Location	Signal	Signal Type
<b>Raw Water Intake</b>	River Water Level	AI
	Raw Water Pump Running Status	DI
	Raw Water Pump Tripped Status	DI
	Raw Water Flowrate	AI
	Raw Water Totalizer	AI (Double Word)
	Raw Water Delivery Pressure	AI
<b>Chemical Plant (Dosing)</b>	Chemical Dosing Pump Running (All)	DI
	Chemical Dosing Pump Tripped (All)	DI
<b>Treated Water Pumping</b>	Treated Water Pump Running Status	DI
	Treated Water Pump Tripped Status	DI
	Clear Water Tank Water Level	AI
	Backwash Tank Water Level	AI
	Treated Water Flowrate	AI
	Treated Water Totalizer	AI (Double Word)
	Treated Water Delivery Pressure	AI
	Raw Water Turbidity	AI

Location	Signal	Signal Type
<b>Admin Building/Lab (Water Quality)</b>	Raw Water pH	AI
	Raw Water Colour	AI
	Settled Water Turbidity	AI
	Settled Water pH	AI
	Filtered Water Turbidity	AI
	Filtered Water pH	AI
	Clarifier Water Colour	AI
	Treated Water Turbidity	AI
	Treated Water pH	AI
	Treated Water Residual Fluoride	AI
	Treated Water Residual Chlorine	AI
	Treated Water Residual Alum	AI
	Treated Water Colour	AI
	High Level Tank Water Level (if any)	AI
<b>LV Substation</b>	Incoming Total Power	DPM Comm
	Incoming Energy	DPM Comm
	Incoming Voltage	DPM Comm
	Incoming Current	DPM Comm
	Incoming pF	DPM Comm
	Incoming Reactive Power	DPM Comm
	Incoming Apparent Power	DPM Comm

Legend: AI = Analog Input, DI = Digital Input

BPS SCADA Contractor shall include the following signals, but not limited to:

Location	Signal	Signal Type
<b>Treated Water Pumping</b>	Pump Running Status	DI
	Pump Tripped Status	DI
	Suction Tank Water Level	AI
	Reservoir Tank Water Level	AI
	Reservoir Tank Outlet Flowrate	AI
	Reservoir Tank Outlet Totalizer	AI (Double Word)
	Treated Water Pumping Flowrate	AI
	Treated Water Pumping Totalizer	AI (Double Word)
	Treated Water Delivery Pressure (Outgoing Pumping Pressure)	AI
	VSD Speed (if applicable)	AI

Legend: AI = Analog Input, DI = Digital Input

WTP SCADA contractor shall provide the following documentation for further information related to the HQ SCADA interfacing, but not limited to:

- a) Each PLCs IP address, port no.;
- b) MODBUS Mapping addressing for the signal as stated in section 4;

- c) Each DPM communication setting, and a set of the MODBUS addressing document;
- d) WTP SCADA system architecture diagram;
- e) Substation electrical single line diagram;
- f) Proposed SCADA signals;
- g) Proposed telco for network; and
- h) WTP overall process diagram.

Any amendment of the configuration shall require approval from JBALB and submission of revised documents shall be made prior to approval. SCADA contractors are required to perform inter-connection testing to verify all MODBUS mapping address are correctly configured. Data verification must be done and witnessed by JBALB for every testing.

Upon completion and T&C of SCADA setup at the WTP, contractor is required to hand over the SCADA software installation CD, manual, network subscription (if applicable), together with the required documents as above to JBALB HQ or JBALB Divisional office.

### **10.5 Last Mile Internet Connection (LMIC)**

All new projects and development under JBALB jurisdiction with SCADA and telemetry (with exception of smart meters) must not be installed with any internet connection without approval. During pre-contract phase, the following processes shall apply:

- a) Any SCADA installation must be a complete ecosystem within local SCADA network (as per requirements above);
- b) Gateway must be allowed for installation of new LMIC to the network;
- c) Architecture design must be submitted to JBALB for submission to SCSDU for installation of Sarawaknet;
- d) In the event that the project has been implemented before this guideline is published, divisional office must apply for Sarawaknet connectivity for that particular water supply facilities. If the current network involves usage of VSAT, FWB, ADSL, fibre optic broadband, mobile broadband or radio telecommunication through subscription, the Sarawaknet installation shall be done right before subscription expired;
- e) Installation of internet network will be borne by SCSDU. Therefore, it shall not be quoted in the tender document;
- f) Scope for installation of SCADA, local SCADA network, gateway and system integration must be provisioned in the tender documents.

## 11 Safety and Security

### 11.1 Security Fencing and Gates

- (a) Treatment Plant, Booster Station, Reservoir areas shall be fenced using at **least 2.5 m high** security fencing: -
- Concrete fence with 3 bard wire or electric fence on top;
  - Heavy duty welded mesh panel anti-cut fence;
  - Reinforcing Fabric of Steel (BRC) fence;
  - Double fence with electric fence inside.
- (b) Quarters shall be fenced separated from treatment plant compound with at least 1.5m chain link security fencing with 3.0 m wide gate.
- (c) Treatment Plant, Booster Station, Reservoir area main gate shall be at least 4.9 m wide with 1.0 m service gate.
- (d) A guard house shall be provided at the main entrance to the treatment plant. If the guard house is located more than 200 m far from any toilet facility, then a toilet and a stand pipe shall be provided.



### 11.2 Other Security Consideration

- (a) CCTV system shall be provided at specific location in treatment plants and booster stations. The CCTV shall be a high quality and reliable video digital network with fully integrated control function. It is required to obtain approval from *Unit Keselamatan dan Penguatkuasaan Sarawak* (UKPS) before implementation.
- (b) Cameras shall be located to monitor the following areas:
- Entry and exit gate
  - Perimeter security fencing
  - Entry and exit of administration building
  - Intake structure
  - Process building and structure
  - Inside pumping station
  - Inside store house
  - Inside chemical mixing building
- (c) Window and door grilles shall be provided in treatment plants and booster stations.

### 11.3 Safety Requirement

1. Besides fire hydrants, adequate firefighting equipment such as fire extinguishers, hose reel systems shall be provided in all the buildings.
2. Smoke detectors, heat detectors, fire alarms shall be provided in accordance to BOMBA requirements.

3. If liquid alum is stored in open tank, a shower/ eye wash area located in a convenient place near to the chemical tanks as possible shall be provided.
4. The hydrogen release outlet for EC system must be installed minimum 5 m above the ground level and ensure there is no farmable activities surround the area.
5. Chlorine detection equipment and alarms, extractor fans shall be provided at all treatment plants.
6. A surge relief valve that protects piping and pipeline systems from pressure surge events caused by rapid valve closure, emergency shut-down or pump trip situations shall be provided.
7. All walkways around filters, sedimentation tanks, high level tank, opening platform etc. where frequently accessed shall be provided with stainless steel or galvanized steel guardrail with mid-rail either on one side or both sides depending on site conditions. The top rail should be at least 1.0 m above the floor.

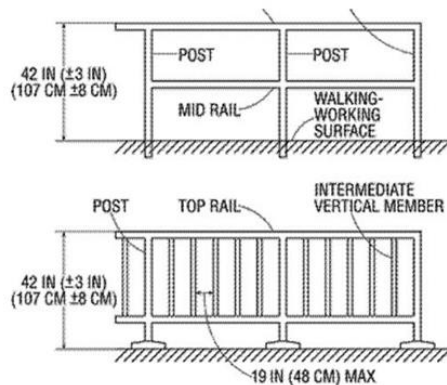

8. Vertical ladders shall be provided with safety devices, such as cage or safety straps.
9. Access ladder inside the reservoir, filter, sediment tank, coagulant tank, raw water intake structure shall be made of rust-free material, such as aluminum.
10. Steel or Concrete staircase shall be provided for all structural buildings from ground to top level.
11. All external stairs and ladders shall be provided with hand railings if considered hazardous.
12. First aid equipment shall be provided in all treatment plants, booster stations and guard houses.
13. Safety devices and equipment meeting the OSHA requirement and regulation shall be provided,
  - Personal Protective Equipment
  - Safety helmet, hearing protection, eye protection, respiratory protection, glove, safety harness, safety shoes, safety reflector vest
  - Portable chlorine detection equipment (for treatment plant and post chlorination plant)
14. A safety and health officer (SHO) or site safety supervisor (SSS) or Occupational Safety and Health Coordinator (OSH-C) shall be employed for work as comply with OSHA requirements.

15. **Safety and Health Plan** Including Safety and Health Policy, Emergency Response Plan, Chemical Safety Data Sheet should be provided within a month after Letter of Acceptance.
16. Monthly Safety Report shall be provided.
17. **Hazard Identification, Risk Assessment and Risk Control (HIRARC)** should be carried out and recorded during contract period. Method, materials and equipment should be selected to remove or minimize risk from work.
18. **Traffic management plan** documents and helps explain how risks will be managed at the construction workplace shall be provided. Traffic control by competent person, traffic and warning signs shall be provided.
19. **Main Gate and Hoarding** shall be provided at the site to stabilize entrances to a construction site for control movement of visitors, clients, workers and vehicles, and to ensure to safe guard the project site and maintain the safety of workers while keeping the general public out of the construction site.

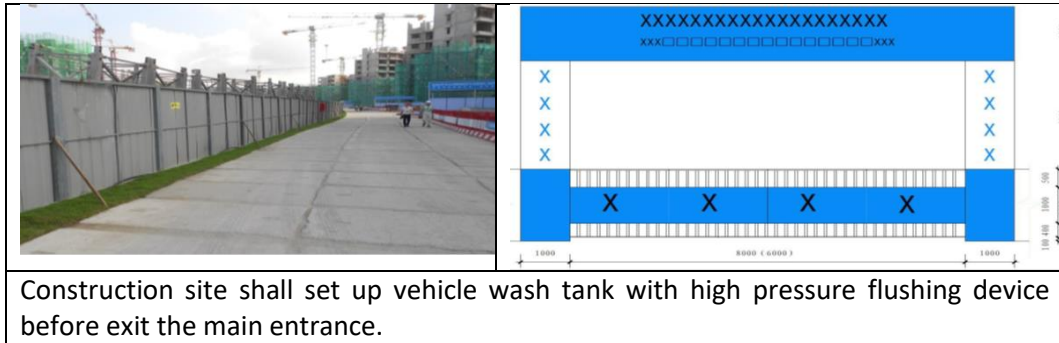

20. Temporary water supply under conditions of ensuring uninterrupted water supply shall be allowed.
21. Safety signs shall be provided to draw attention to objects and situations which affect or could affect health or safety.
  - Prohibition signs
  - Warning signs
  - Mandatory signs
  - Safe condition signs
22. Supply, erection and dismantle scaffolding, working platform with safety net shall be provided.
23. Cordoning off working area and provision of public control and safety measures where lifting operations, moving, shifting, transferring works are carried out outside the hoarded-up area of the worksite shall be provided.
24. Measures to prevent the breeding of mosquitoes, houseflies, rats, insects and other dangerous animals on the Site throughout the contract period shall be allowed.
25. A **Confined Space** entry programme with Safe Working Procedure (SWP) shall be developed and implemented to enter a confined space.
  - Provide an adequate and effective ventilation to always maintain the contaminants concentration level as low as possible, and the level of oxygen within safe range.
  - Training shall be provided in all work with confined space.



26. **Living quarters** for workers shall be provided and isolate from the construction operation zone.
  - Portable fire extinguishers shall be provided adequately.
  - Provided with supply of water and electricity.
  - Toilet and washing building shall separate from living units at least 10 m apart with septic tank.
27. **Permit-To-Work (PTW)** must be obtained before any construction activity be carried out. PTW is a formal, written, safe system of work to control potentially hazardous activities. The permit details the works to be done and the precautions to be taken (for instance, they may involve limiting the movement of overhead cranes, the precautions needed for high voltage work, or they might details rescue arrangement for certain type of works).
28. Booster station should be provided with toilet facilities and office for the attendant.

## 12 Testing and Commissioning for Water Treatment Plant / Booster Pump Station

- (a) Testing & commissioning for the whole system at Water Treatment Plant shall be 24hours continuously running for 7 days period.
- (b) Testing & commissioning for the whole system at Booster Station shall be 24hours continuously running for at least three (3) days period.

## 13 Color Code

### 1. Quarter

(a) Roof – Bright Blue (#0096FF)



(b) Wall – White (#FFFFFF) at Top



(c) Wall – Grey (#808080) at Bottom



### 2. Water Treatment Plant and Booster Station

a) Roof – Bright Blue (#0096FF)



b) Wall – Light Blue (#ADD8E6)



c) Column – Denim (#6F8FAF)



### 3. Tank and tower structure

(a) White (#FFFFFF)

(b) Cotillion Red (#B43D35)

(c) Golden Dome (#FFC035)

(d) Black (#000000)



## 14 Reference

1. MWA Planning Guidelines and Best Practices Handbook for Water Supply Systems (Volume 1: 2021 Edition)
2. MWA Design Guidelines for Water Supply Systems (December 1994)
3. General Specification for Water Main Construction (October 2011)
4. Guidelines and Requirements For Water Supply Systems In Sarawak (Ref: SWSCC/DIR.1/2002WTC 1/98)
5. SPAN Uniform Technical Guidelines for the Design of Water Treatment Plants and Related Water Supply System Components (First Edition, May 2021)
6. Environmental Quality Act 1974: Environmental Quality (Industrial Effluent) Regulations 2009
7. Occupational Safety and Health Act 1994
8. Factory Machinery Act (FMA 1967)
9. Construction Industry Development Board (CIDB) Act 520
10. Building Operations And Works Of Engineering Construction (Safety) Regulations,1986
11. DOSH Guidelines for the Prevention of Falls at Workplaces
12. DOSH Guidelines For Public Safety And Health At Construction Sites (1st Revision: 2007)
13. Best Practice on Occupational Safety and Health in Construction Industry 2019
14. OSH Management in Construction Industry Guideline (OSHCIM 2017)
15. Supply System Components (Second Draft Guidelines Rev. 0-0 9 April 2021)
16. IEC 61557-12 standard - Electrical Installation Guide
17. Communication and Multimedia (Spectrum) Regulations 2000 P.U(A) 128/2000
18. Sarawak Multimedia Authority Ordinance 2017
19. Standard Guideline for Underground Utility Mapping (May 2006)
20. *Garis Panduan Pengurusan Peralatan ICT V 1.3 (2018)*
21. MS 1759:2004 – Geographic Information/Geomatics – Features and Attribute Codes
22. HP32 - Hydrological Standard for Rainfall Station Instrumentation
23. MS 2320:2010 : Drinking Water – Quality Requirements and *Standard Kualiti Air Kebangsaan*
24. Guidelines on Design and Planning of Water Treatment Plant and Equipment, dated 29.01.2021. By Technical Advisor Ir. WWA (PPT file)

25. Theory Application and Design of Air Valves along Pipelines. By Cho KM, Chief hydraulic Engineer, 2012.
26. National Standard for Drinking Water Quality, 2<sup>nd</sup> revision January 2004, Ministry of Health Malaysia.

## **15 Attachment**

**15.1 Checklist on design report for Watermain, Booster Station and Reservoir**

**15.2 Check list on tender drawing for Watermain, Booster Station and Reservoir**

**15.3 Checklist on design report for Water Treatment Facilities**

**15.4 Testing and Commissioning Document for Booster Station**

**15.5 Testing and Commissioning Document for Water Treatment Plant**

**Checklist on design report  
for  
Watermain, Booster Station and Reservoir**

## JABATAN BEKALAN AIR LUAR BANDAR

### CHECKLIST FOR WATERMAINS/BOOSTER STATION/RESERVOIR(\*)

Name of Project: \_\_\_\_\_

Type of Report Sub Title: \_\_\_\_\_ Conceptual/preliminary/Interim/Draft Final/Final(\*) Design Report

Name of Consultant: \_\_\_\_\_

(\* Delete whichever not applicable; N.A. denotes Not Applicable)

Item	Description	Status (YES/ NO /N.A.)	Remarks
(A)	<b><u>GENERAL</u></b>		
1.	Is title of project correct?		
2.	Does front cover has title of project, name of report, name of client, name of consultant and month/year of report?		
3.	Table of contents with paging provided		
4.	Introduction provided		
5.	Background & objective of project provided		
6.	Scope of works of the project provided		
7.	Description & map of supply area provided in relation to existing water supply system		
8.	Cost estimates with detailed breakdown & overall project cost are provided		
9.	Proposed schedule of implementation of the project is provided		
10.	Wayleave application		
11.	Please indicate in the remark column the type of the road:		
	(i) JKR Road (State)		
	(ii) JKR Road (Federal)		
	(iii) Rural Road		
	(iv) Kampung road		
	(v) Council road		
	(vi) Etc (Please state)		
12.	Siting application		
13.	Subsurface Investigation works. (State how many boreholes and Mackintosh Probes required)		
14.	Survey works		
(B)	<b><u>POPULATION</u></b>		
1.	Population statistics for each kampong/area/school/ institution provided		
2.	Projected population & water demand provided		
3.	Is projection period based on design life of 30 years?		
4.	Is population growth rate based on historical record?		
5.	If answer to Item 4 above is no, is population growth rate used in projection reasonable?		
6.	Is population projection provided based on 5 yearly intervals?		
7.	Are the projected population figures acceptable?		

**JABATAN BEKALAN AIR LUAR BANDAR**

**CHECKLIST FOR WATERMAINS/BOOSTER STATION/RESERVOIR(\*)**

(C)	<b><u>WATER DEMAND</u></b>		
1.	Water demand for population based on Design Guidelines		
2.	Water demand for commercial area based on Design Guidelines		
3.	Water demand for institutions based on Design Guidelines		
4.	Water demand for industrial area based on Design Guidelines		
5.	Peak consumption factor of 2.5 is used.		
6.	Fire fighting demand based on Design Guidelines.		
7.	Allowance of 25% for non-revenue water provided.		
8.	Is the projected total water demand acceptable?		
(D)	<b><u>PROPOSED GRAVITY PIPELINES</u></b>		
1.	Layout plan of proposed pipelines in relation to existing mains provided together with proper labeling of the pipelines and kampungs		
2.	Any pipe material comparison analysis including suitability of pipe in soil & environmental conditions encountered, material & installation costs, O & M costs, etc. before selecting the pipe material to be used?		
3.	Hydraulic analysis of proposed pipelines are provided for the following: -		
	(a) average flow		
	(b) peak flow		
	(c) peak flow + fire flow		
4..	Node diagrams showing the node junctions, pipes nos. draw-off rate at each kampung, flow rate in each of the pipe no., reduced levels at the kampungs/ reservoirs/suction tanks, names of kampungs are provided for the following: -		
	(a) average flow		
	(b) peak flow		
	(c) peak flow + fire flow		
5.	Is the water pressure used in the hydraulic analyses based on projected pressure in 30 years' time?		
6.	Are the input data used in the hydraulic analyses correct?		
7.	Are the reports on the results of the hydraulic analyses provided?		
8.	Is the residual pressures meet the requirements of 10 metres for the following cases:-		
	(a) average flow		
	(b) peak flow		
	(c) peak flow + fire flow		
9	Can the selected pipe material and pressure rating withstand 1.5 time of the MSDWP in the proposed pipeline system?		
10.	Pipeline design comply to way leave requirement from JKR		

**JABATAN BEKALAN AIR LUAR BANDAR**

**CHECKLIST FOR WATERMAINS/BOOSTER STATION/RESERVOIR(\*)**

11.	Chlorine Residual at the end of proposed pipeline not less than 0.2ppm according to National Standard for Drinking Water Quality		
12	If chlorine residual at end of existing pipeline cannot give a chlorine residual of 0.2ppm, then a system is provided to boost the chlorine to give sufficient chlorine residual at end of proposed pipeline		
(E)	<b><u>SUBMARINE MAINS</u></b>		
1.	Layout plan and longitudinal profile of proposed submarine main provided.		
2.	Any pipe material comparison analysis including suitability in submarine conditions encountered, material & installation costs, O & M costs, etc. before selecting the pipe material to be used?		
3.	Submarine investigation with regard to current forces, wave forces, tidal conditions, etc. carried out and reported in design report.		
4.	Calculations on the forces acting on the submarine main provided and found acceptable.		
5.	Calculations on the concrete ballasts provided and found acceptable.		
6.	Comparison of the options for the installation of the submarine main such as laying on river bed, trenching and HDD is provided including capital and O & M costs before recommending which option to be used.		
7.	Is the recommended, option for installation of the proposed submarine main acceptable?		
8..	Is the spacing of the concrete ballasts acceptable?		
9.	Are twin submarine mains proposed?		
10.	Is the spacing between the two submarine mains acceptable?		
11.	Are the ends of the submarine mains at the river banks properly anchored?		
12..	Are anchorage signs provided?		
13.	Are the proposed jointing methods for the pipes acceptable?		
14.	Is the installation method of the concrete ballasts on the submarine main acceptable?		
15.	Can the selected pipe material and pressure rating withstand 1.5 time of the MSDWP in the proposed pipeline system?		
16.	Comply with Sarawak River Board requirement		
(F)	<b><u>PROPOSED PUMPING MAINS</u></b>		
1.	Layout plan of proposed pumping mains in relation to existing or proposed pipeline system provided.		
2.	Any pipe material comparison analysis including suitability of pipe in soil & environmental conditions encountered, material & installation costs, O & M costs, etc. before selecting the pipe material to be used?		

**JABATAN BEKALAN AIR LUAR BANDAR**

**CHECKLIST FOR WATERMAINS/BOOSTER STATION/RESERVOIR(\*)**

3.	Calculations on static head, friction losses and total pumping head provided.		
4..	Calculations on surge analysis provided.		
5	Adequacy of surge vessel or surge-anticipating relief valve.		
6.	Can the selected pipe material and pressure rating withstand 1.5 time of the MSDWP in the proposed pipeline system?		
7.	Pipeline design comply to way leave requirement from JKR		
8.	Chlorine Residual at the end of proposed pipeline not less than 0.2ppm according to National Standard for Drinking Water Quality		
9.	If chlorine residual at end of existing pipeline cannot give a chlorine residual of 0.2ppm, then a system is provided to boost the chlorine to give sufficient chlorine residual at end of proposed pipeline		
(G)	<b><u>BOOSTER STATION</u></b>		
1.	<b><u>GENERAL</u></b>		
	(a) Layout plan showing the location of the proposed booster station site in relation to existing and proposed water supply system provided.		
	(b) Location chosen for the proposed booster station is acceptable in terms of required ground level to receive incoming water.		
	(c) Layout plan of the booster station site showing the suction tank, pump house, high level tank (if located at the same site), generator house, toilet, substation, access road, drainage system, fencing, etc. is provided and found to be acceptable.		
	(d) Survey plan showing the contours and the proposed platform levels for the suction tank, pumphouse and high level tank (if located on the same site) is provided and found to be acceptable.		
	(e) Site proposed for land acquisition has adequate space for future extension		
	(f) Is a toilet provided for booster station?		
	(g) Is Sub-station meet Sarawak Energy Berhad (SEB) requirement?		
	(h) All electrical works including switchboard, cablings lightings, etc are in order.		
	(i) Minimum security fencing must be provided of height at least 2.5 meter.		
2.	<b><u>SUCTION TANK</u></b>		
	(a) Suction tank has a minimum capacity equivalent to eight (8) hours pumping rate.		
	(b) Calculations to determine the capacity of the suction tank are provided and found to be acceptable.		
	(c) Material of construction for suction tank is reinforced concrete unless otherwise approved.		

**JABATAN BEKALAN AIR LUAR BANDAR**

**CHECKLIST FOR WATERMAINS/BOOSTER STATION/RESERVOIR(\*)**

	(d) Suction tank with capacity more than 1 ML shall has a central partition for O & M purposes.		
	(e) Suction tank has separate suction pipe connected directly to each pump.		
	(f) All pipeworks for the suction tank are shown and in order.		
	(g) Piling for suction tank is provided.		
	(h) Painting for the suction tank is provided.		
	(i) Level indicator is provided.		
<b>3.</b>	<b><u>PUMP HOUSE</u></b>		
	(a) Internal layout of the pump house showing the pump plinths, pumps, switchboard, pipeworks, cable trenches, etc. is provided and found to be acceptable.		
	(b) Calculations on the pumping capacity and head are provided and found to be in order.		
	(c) Adequate duty and standby pumps are provided.		
	(d) The type of pumps proposed is acceptable.		
	(e) Surge pressure analysis provided to justify the need for surge tank or surge anticipating relief valve.		
	(f) Piling for the pump house is provided.		
	(g) All electrical works including switchboard, cablings, lightings, etc are in order.		
<b>4.</b>	<b><u>GENERATOR HOUSE</u></b>		
	(a) Internal layout of the generator house showing the generator, switchboard, cable trenches, etc. is provided and found to be acceptable.		
	(b) Calculations on the generator capacity is provided and found to be in order.		
	(c) All electrical works including switchboard, cablings, lightings, etc are in order.		
	(d) Piling for the generator house is provided.		

**JABATAN BEKALAN AIR LUAR BANDAR**

**CHECKLIST FOR WATERMAINS/BOOSTER STATION/RESERVOIR(\*)**

(H)	<b>RESERVOIR</b>		
	(a) Layout plan showing the location of the proposed reservoir site in relation to existing and proposed water supply system provided.		
	(b) Layout plan of the reservoir site showing the tank access road, drainage system, fencing, etc. is provided and found to be acceptable.		
	(c) Reservoir has minimum capacity of 24 hours storage.		
	(d) Calculations to determine the capacity of the reservoir are provided and found to be in order.		
	(e) Material of tank is reinforced concrete unless otherwise approved		
	(f) Reservoir with capacity more than 1 ML shall has a central partition for O & M purposes.		
	(g) Standby outlet is provided.		
	(h) Pipeworks for the reservoir are shown.		
	(i) Piling for the reservoir is provided.		
	(j) Painting works for the reservoir is provided.		
	(k) Level indicator is provided.		
	(l) Bypass system		
	(m) Minimum security fencing must be provided of height at least 2.5 meter.		
	(n) Staircase from the ground to tank		
	(o) Compound light		

**Checklist on tender drawing  
for  
Watermain, Booster Station and Reservoir**

**JABATAN BEKALAN AIR LUAR BANDAR SARAWAK**

**CHECKLIST ON TENDER DRAWINGS  
FOR WATERMAINS/BOOSTER STATION/RESERVOIR(\*)**

Name of Project: \_\_\_\_\_

Tender Drawings Submitted: 1<sup>st</sup> Draft / 2<sup>nd</sup> Draft / 3<sup>rd</sup> Draft / Final (\*)

Name of Consultant: \_\_\_\_\_

(\* Delete whichever not applicable; N.A. denotes Not Applicable)

Item	Description	Status (Yes / No/ N.A.)	Remarks
<b>(A)</b>	<b><u>GENERAL</u></b>		
1.	Are details on the cover page, including the project title correct?		
2.	A list of drawings with details on item no., drawing title and drawing no. provided.		
3.	Locality plan is provided.		
4.	Are survey bench marks shown in all the relevant plans?		
5.	Have the plans been signed and stamped by the registered professional engineer responsible for this project?		
6.	Are 'Notes' provided where required on the relevant plans?		
7.	Are 'Legends' provided where required on the relevant plans?		
8.	Proper drawing scales are shown in all drawings for each plan or sectional view.		
<b>(B)</b>	<b><u>OVERALL LAYOUT PLAN</u></b>		
1.	Is overall layout plan showing all the project components provided? ( <u>Note</u> : This overall layout plan should be based on L & S topographical map)		
2.	Is the proper drawing scale shown?		
3.	Are the following project components properly shown and labeled:		
	(a) watermains with the sizes, type of material and pressure ratings indicated.		
	(b) booster station site showing the pumphouse and suction tank with storage capacity & material of tank indicated.		
	(c) reservoir with storage capacity and material of reservoir indicated.		
4.	Are existing pipelines and other water supply facilities such as intake, treatment plant, reservoirs, booster station, etc. shown?		
5.	Are names of town, kampungs, roads, rivers, etc. shown?		
<b>(C)</b>	<b><u>SCHEMATIC DIAGRAM</u></b>		
1.	Is schematic diagram showing all the project components in relation to existing facilities provided?		

**JABATAN BEKALAN AIR LUAR BANDAR SARAWAK**

**CHECKLIST ON TENDER DRAWINGS  
FOR WATERMAINS/BOOSTER STATION/RESERVOIR(\*)**

2.	Are the project components and existing facilities properly labelled?		
3.	Are ground levels, bottom and top water levels of water tanks or reservoirs and other relevant levels shown?		
4.	Are project components, existing facilities and features properly labeled?		
5.	Are interconnection points clearly shown?		
6.	Are legends provided?		
7.	The sizes, pressure ratings & lengths of the pipelines, the tank/reservoir capacities, etc. are shown.		
<b>(D)</b>	<b><u>HYDRAULIC PROFILE</u></b>		
1.	Is hydraulic profile of the proposed system provided?		
2.	Are the project components and existing facilities (where relevant) shown?		
3.	Are the project components and existing facilities shown properly labelled?		
4.	Are the levels at all the project components and existing facilities shown?		
5.	Is the existing ground profile shown together with the distances between the components?		
6.	Are pump capacities and pumping heads indicated?		
7.	Is the hydraulic profile correctly shown? (To check against design report & calculations)		
<b>(E)</b>	<b><u>PROPOSED PIPELINES</u></b>		
<b>1.</b>	<b><u>KEY PLANS OF PIPE ROUTES</u></b>		
	(a) Key plans showing the overall pipe routes surveyed together with the drawing nos. for each pipe routes are provided.		
	(b) The sizes, pressure ratings, materials and lengths of pipelines are indicated and in accordance with approved final design report.		
	(c) Notes on the requirements for mainlaying works, material specifications, thrust blocks, marker posts, air valves, sluice valves, fire hydrants, etc. are provided.		
	(d) Legends on the proposed pipelines, etc. are provided.		
<b>2.</b>	<b><u>PLAN VIEWS OF PIPELINES</u></b>		
	(a) Plan views of pipelines are provided.		
	(b) The alignments of the pipelines are clearly indicated. (To check they follow the approved wayleaves)		
	(c) All the pipelines, air valves, sluice valves, washouts, fire-hydrants, etc. where required are clearly shown and labeled. The pipe size, pressure rating and material are clearly indicated.		
	(d) All the relevant notes and legends on the symbols used are provided.		
	(e) All chainages at 20 metre intervals are indicated.		
	(f) Matchlines are given.		
	(g) Relevant features such as houses, lot no. & boundaries, electrical posts, bridges, culverts, rivers, drains, etc. are shown.		

**JABATAN BEKALAN AIR LUAR BANDAR SARAWAK**

**CHECKLIST ON TENDER DRAWINGS  
FOR WATERMAINS/BOOSTER STATION/RESERVOIR(\*)**

<b>3.</b>	<b><u>LONGITUDINAL PROFILES OF PIPELINES</u></b>		
	(a) Longitudinal profiles of pipelines are provided.		
	(b) Existing ground levels of pipeline route are taken at 20 metre intervals.		
	(c) Existing ground levels of pipeline route are also taken at points necessary to show any significant changes in slope.		
	(d) At all streams, bridge and culvert crossings, the following information are obtained.		
	(i) Cross-sections of streams along the pipeline route giving levels at intervals sufficiently close to show the bed levels.		
	(ii) The soffit level of the longitudinal beam of the bridges, together with their span and the locations of the column.		
	(iii) The invert levels and the crown levels of all culverts.		
	(e) Longitudinal sections along the pipe route are drawn to a scale of 1 in 100 (vertical) and 1 in 1000 (horizontal)		
	(f) The size, material and pressure rating of the pipeline is stated.		
	(g) Chainages are clearly indicated.		
	(h) Proposed pipe invert levels are given and designed to provide generally a soil cover of 1000 mm. to the top of the pipeline.		
	(i) Where the soil cover to the top of the pipes is less than 450 mm, the pipes are encased in reinforced concrete surround of minimum 150 mm and provided with contraction joints.		
	(j) The pipelines are laid to a minimum gradient of 1:500.		
	(k) Pipe connections to existing mains are clearly indicated.		
	(l) Details of pipe connections to existing mains are provided.		
<b>4.</b>	<b><u>THRUST BLOCKS &amp; ANCHOR BLOCKS</u></b>		
	(a) Properly designed thrust blocks or anchor blocks are provided for the following:		
	(i) at horizontal and vertical bends, tees, tapers, reducers, end caps, line valves and at points where an unbalanced thrust occurs.		
	(ii) one in every 3 pipe lengths for pipes laid on a 1:12 slope.		
	(iii) one in every 2 pipe lengths for pipes laid on a 1:8 slope.		
	(iv) one in every pipe length for pipes laid on a 1:5 slope.		
	(b) The sizes of the anchor and thrust blocks are as per design calculations which are based on actual soil bearing capacity.		

**JABATAN BEKALAN AIR LUAR BANDAR SARAWAK**

**CHECKLIST ON TENDER DRAWINGS  
FOR WATERMAINS/BOOSTER STATION/RESERVOIR(\*)**

	(c) Where necessary, the pipes or fittings are properly fastened onto the thrust or anchor blocks using hot dipped galvanized mild steel straps with 10 mm thick synthetic rubber padding and hot dipped galvanized mild steel bolts.		
	(d) Proper and adequate piling is provided where required.		
<b>5.</b>	<b><u>PIPELINE SLUICE/BUTTERFLY VALVES</u></b>		
	(a) The pipelines valves proposed comply with the following:-		
	(i) For pipeline up to 400 mm. diameter, sluice valves are used.		
	(ii) For pipelines of 450 mm diameter and above, butterfly valves are used.		
	(iii) Pipeline valves are spaced at about 1,500 m. intervals.		
	(iv) At a tee intersection, two valves are provided.		
	(v) At a cross intersection, three valves are provided.		
<b>6.</b>	<b><u>AIR VALVES</u></b> <u>Note:</u> (1) Double air valves can be of single body or dual body type depending on design requirement and calculations. (2) A peak is located by reference to the hydraulic gradient and not to necessarily to the horizontal datum line.		
	(a) Air valves are provided along the pipelines at the following points:		
	i. at all peak points		
	ii. at points of abrupt increase in downward slope.		
	iii. at abrupt decrease in upward slope.		
	iv. single large orifice air valve at downstream of the pump delivery valves.		
	v. along long horizontal runs at about 800 m. intervals.		
	vi. single air valves at small up and over culvert crossings.		
	vii. Double air valves for larger stream and river crossings.		
	viii. Double air valves at beginnings of horizontal runs after ascents.		
	ix. Double air valves at ends of horizontal runs before descents.		
	(b) The types and sizes of the air valves proposed at the various locations of the pipelines are properly designed based on design calculations / manufacturer's performance graphs for air valves/air valve sizing software to prevent water hammer, air pockets and vacuum suction. ( <u>Note:</u> To check against design report & calculations)		

**JABATAN BEKALAN AIR LUAR BANDAR SARAWAK**

**CHECKLIST ON TENDER DRAWINGS  
FOR WATERMAINS/BOOSTER STATION/RESERVOIR(\*)**

<b>7.</b>	<b><u>HYDRANTS</u></b>		
	Pillar hydrants for the pipelines comply with the following:		
	(i) provided only where there are houses, shophouses, longhouses, office buildings or institutions along the pipelines.		
	(ii) spacing interval between hydrants is not more than 180 metres.		
	(iii) For high risk installations, the hydrants are placed not more than 90 metres walking distance from the installations.		
	(iv) Screw down/ sluice valve pillar hydrants are provided at the ends of pipelines		
<b>8.</b>	<b><u>WASHOUTS</u></b>		
	(a) Washouts are located at all low points of the pipelines.		
	(b) Minimum size of washouts is 100 mm.diameter		
	(c) Washouts are connected to the nearest drains by HDPE pipes.		
	(d) Washouts are sized to give a minimum watermain velocity of 0.8 m/s ( <u>Note</u> : To check against design calculations)		
<b>9.</b>	<b><u>VALVE CHAMBERS</u></b>		
	(a) All valves for buried pipelines are housed in chambers		
	(b) Drawings of the valve chambers are provided for the following:		
	(i) sluice valves		
	(ii) butterfly valves		
	(iii) pillar hydrants		
	(iv) Screw down / sluice valve pillar hydrants		
	(v) single air valves		
	(vi) double air valves		
	(v) washouts		
	(vi) pressure reducing valves		
	(vii) reflux valves		
	(c) Precast concrete valve chambers are proposed for the following:		
	(i) 150 mm, 200 mm. and 250 mm. diameter sluice valves		
	(ii) 25 mm and 50 mm single orifice air valves		
	(iii) 50 mm and 80 mm dual orifice air valves		
	(iv) 100 mm diameter washouts		
	(v) pillar hydrants		
	(vi) sluice valve pillar hydrant		
	(d) Reinforced concrete or brick chambers are proposed for the following:		
	(i) sluice valve of diameter 300mm and above.		
	(ii) butterfly valves of diameter 450mm and above		

**JABATAN BEKALAN AIR LUAR BANDAR SARAWAK**

**CHECKLIST ON TENDER DRAWINGS  
FOR WATERMAINS/BOOSTER STATION/RESERVOIR(\*)**

	(e) Reinforced concrete chambers are proposed for the following cases:		
	(i) depth of valve chamber greater than 3 meters		
	(ii) pipes in chambers are of diameter greater than 600 mm		
	(f) Reinforced concrete and brick valve chambers proposed have the following general features:		
	(i) the distance between the wall and the edge of the joint is at least 150 mm for pipes not exceeding 450 mm while for pipes greater than 450 mm, the distance should be at least 300 mm.		
	(ii) the chamber width or length shall not be smaller than 750 mm.		
	(iii) the base has a minimum thickness of 150 mm.		
	(iv) valves are installed on mass concrete supports		
	(v) chambers deeper than 1.0 metre are provided with 20 mm. wrought iron steps spaced at 300 mm interval.		
	(vi) valve chambers are provided with reinforced concrete covers which have lifting facilities.		
	(vii) the nearest pipe joint outside the chamber has a flexible mechanical coupling.		
	(viii) conventional flanged adapters are used for pipes up to 300mm diameter.		
	(ix) special flanged adaptors are used for pipes of diameter greater than 300 mm.		
<b>(F)</b>	<b><u>BOOSTER STATION</u></b>		
<b>1.</b>	<b><u>GENERAL</u></b>		
	(a) Overall layout plan of booster station site showing proposed suction tank, pumphouse, generator house, watermains, high level tank (if on same site), proposed access road, fencing and drainage system in relation to existing road, watermains, etc. is provided and found to be acceptable with the pumphouse located close to the suction tank.		
	(b) Survey plan showing the contours and the proposed platform levels for the suction tank, pumphouse, high level tank (if on the same site) and required earthworks is provided and found to be acceptable.		
	(c) Proposed booster station site is large enough for future extension of suction tank, pumphouse, generator house and high level tank (if on same site)		
	(d) Survey reference points are provided with the bearings and levels given.		
	(e) All the components shown are labeled and with the dimensions, capacities, etc. indicated.		
	(f) The booster station site is above maximum flood level.		
<b>2.</b>	<b><u>SUCTION TANK</u></b>		

**JABATAN BEKALAN AIR LUAR BANDAR SARAWAK**

**CHECKLIST ON TENDER DRAWINGS  
FOR WATERMAINS/BOOSTER STATION/RESERVOIR(\*)**

	(a) Layout plan and sectional views of the suction tank are provided.		
	(b) The suction tank 1ML and above has a partition.		
	(c) All the components including the inlet pipes, suction pipes, overflow pipes, scour pipes, low level cut off device with alarm system, manholes, ventilators, level gauges, modulating float valves, ladders, etc. are shown in the layout plan and sectional views and are in order.		
	(d) R.C. drawings of the suction tank are provided.		
	(e) All the components shown in the construction and R.C. drawings are labeled and with the dimensions, capacities, material of construction, etc. indicated.		
	(f) The length of the suction pipes from the suction tank to the pumps is kept to the minimum.		
	(g) Separate suction pipes are provided for each pump.		
	(h) Valve chambers are provided with details given.		
	(i) Thrust blocks and anchor blocks are provided for bends, valves, etc. with details given.		
	(j) Puddle pipes are used at walls of suction tank and R.C. valve chambers.		
	(k) Foundation and piling details for suction tank are provided.		
<b>3.</b>	<b><u>PUMPHOUSE</u></b>		
	(a) Layout plan and sectional views of the suction tank are provided.		
	(b) layout plan showing all the components such as pump plinths, pumps, switchboard, instrument panels, pipeworks, cable trenches, surge tank, electromagnetic flow meter, future pump plinths, etc is found to be acceptable.		
	(c) Sectional views of the pumphouse showing the traveling crane, pipeworks, cable trenches, pump plinths, pumps, etc. are found to be acceptable.		
	(d) R.C. drawings of the pumphouse are provided.		
	(e) All pipes and cables in the pumphouse are laid in trenches with chequer plate covers.		
	(f) The minimum width of the pipe trench is the diameter of the pipe plus 150mm space on each side of the pipe.		
	(g) Secondary chlorination is provided at the pumphouse where residual chlorine at the proposed booster station site falls below 0.10 ppm. There is enough space for one duty and one standby chlorinators, a month's storage of chlorine cylinders or hypochlorite and the required pipeworks. Chlorination facilities are housed separately with separate access.		
	(h) Provide for the operator's room and toilet facilities.		

**JABATAN BEKALAN AIR LUAR BANDAR SARAWAK**

**CHECKLIST ON TENDER DRAWINGS  
FOR WATERMAINS/BOOSTER STATION/RESERVOIR(\*)**

	(i) All the components shown in the drawings are labeled and with the dimensions, capacities, material of construction, etc. indicated.		
	(m) Details of pumphouse foundation and piling are provided.		
	(n) The height of the pumphouse building is high enough for installation and operation of the pump and the lifting equipment.		
	(o) Adequate duty and standby pumps are provided.		
	(p) The type, capacity, material of construction of the pumps are acceptable. ( <u>Note</u> : To check against design report & calculations).		
<b>4.</b>	<b><u>GENERATOR HOUSE</u></b>		
	(a) Layout plan and sectional views of the generator house are provided.		
	(b) Layout plan showing all the components such as generators, generator plinths, main switchboard, cable trenches, fuel tank, bulk tank, lifting equipment, etc. is found to be acceptable.		
	(c) Sectional views showing the generators, generator plinths, main switchboard, cable trenches, fuel tank, bulk tank, lifting equipment, etc. are found to be acceptable.		
	(d) R.C. drawings of the generator house are provided.		
	(e) Details of the generator house foundation and piling are provided.		
	(f) The type and capacity of the generator are acceptable. ( <u>Note</u> : To check against design report & calculations)		
<b>(G)</b>	<b><u>RESERVOIR</u></b>		
	(1) Overall layout plan of reservoir site showing reservoir, access road, drainage, fencing, pipeworks, etc. is acceptable.		
	(2) Survey plan showing the contours, proposed platform levels and required earthworks is acceptable.		
	(3) Layout plan and sectional views of the reservoir are provided.		
	(4) The reservoir 1ML and above has a partition,		
	(5) The layout plan and sectional views showing all the components such as the inlet pipes, outlet pipes, overflow pipes, scour pipes, manholes, ventilators, ladders, level gauges, altitude valve, electromagnetic flowmeter, etc. are acceptable.		
	(6) The reservoir is sited away from slopes to avoid undermining of reservoir due to possible slope erosion.		
	(7) Erosion prevention measures such as retaining walls, etc. are provided where necessary.		
	(8) R.C. drawings of the reservoir are provided.		
	(9) Valve chambers are provided with details given.		
	(10) Thrust blocks and anchor blocks for bends, valves, etc. are provided with details given.		

**JABATAN BEKALAN AIR LUAR BANDAR SARAWAK**

**CHECKLIST ON TENDER DRAWINGS  
FOR WATERMAINS/BOOSTER STATION/RESERVOIR(\*)**

	(11) Puddle pipes are used at walls for reservoir and R.C. valve chambers.		
	(12) Foundation and piling details of reservoir and R.C. valve chambers are provided.		
	(13) Lightning arrestor and aircraft warning light are provided.		
	(14) Compound lighting at reservoir site is provided.		
	(15) The capacity and levels of the reservoir and the height of the tower (where applicable) are acceptable. <b>(Note: To check against design report &amp; calculations)</b>		
	(16) Standby outlet pipe provided.		
	(17) Detailed of bypass system		
<b>(H)</b>	<b><u>MECHANICAL AND ELECTRICAL WORKS</u></b>		
	(1) Single Line diagrams are provided for the pumphouse and generator house.		
	(2) Details of mechanical installation works such as soil, sanitary and cold water systems are provided and in order.		
	(3) Details of electrical installation works such as lightings, cablings, switchboards, etc. for the pumphouse and generator house are provided and in order.		
	(4) Lightning protection installations are provided for the pumphouse and generator house and are in order.		
	(5) Details of fire fighting services for pumphouse and generator house are provided and in order.		
<b>(I)</b>	<b><u>TYPICAL WATER SUPPLY DETAILS</u></b>		
	Typical water supply details are provided for the following and are found to be in order:		
	(a) Thrust blocks and anchor blocks.		
	(b) Precast concrete chambers for air valves.		
	(c) Precast concrete chambers for sluice valves.		
	(d) Precast concrete chambers for washouts.		
	(e) Precast concrete chambers for pillar hydrants.		
	(f) Precast concrete chambers for sluice valve pillar hydrants.		
	(g) R.C. chambers for sluice valves.		
	(h) R.C. chambers for butterfly valves.		
	(i) R.C. chambers for pressure reducing valves.		
	(j) R.C. chambers for altitude valves.		
	(k) R.C. chambers for electromagnetic flowmeters.		
	(l) culvert crossing.		
	(m) Drain crossings		
	(n) River crossings.		
	(o) Pipe supports at bridge crossings.		
	(p) Marker posts.		
	(q) Concrete encasement for pipes.		

**Checklist on design report  
for  
Water Treatment Facilities**

**JABATAN BEKALAN AIR LUAR BANDAR SARAWAK**

**CHECKLIST ON DESIGN REPORT FOR WATER TREATMENT SYSTEMS**

Name of Project: \_\_\_\_\_

Type of Report: Draft Final/Final Design Report (\*)

Name of Consultant: \_\_\_\_\_

(\* Delete whichever not applicable; N.A. denotes Not Applicable)

<b>Item</b>	<b>Description</b>	<b>Status (Yes / No / N.A)</b>	<b>Remarks</b>
(A)	<b><u>GENERAL</u></b>		
1.	Is title of project correct?		
2.	Does front cover has title of project, name of report, name of client, name of consultant and month/year of report?		
3.	Table of contents with paging is provided.		
4.	Executive Summary is provided.		
5.	Introduction is provided.		
6.	Background & objective of project are provided.		
7.	Scope of works of the project is provided.		
8.	Description & map of supply area are provided in relation to existing water supply system.		
9.	Alternative design proposals with layout plans are provided together with recommendation of option to be adopted.		
10.	Cost estimates with detailed breakdown, overall project cost or each alternative design proposal are provided.		
11.	Hydraulic and structural O&M costs and financial analysis calculations for the various components are provided.		
12.	Proposed schedule of implementation of the project is provided.		
(B)	<b><u>POPULATION</u></b>		
1.	Population statistics for each kampong/area/school/institution provided.		
2.	Projected population & water demand provided.		
3.	Is projection period based on design life of 30 years?		
4.	Is population growth rate based on historical record?		
5.	If answer to Item 4 above is no, is population growth rate used in projection reasonable?		
6.	Is population projection provided based on 5 yearly interval?		
7.	Are the projected population figures acceptable?		
(C)	<b><u>WATER DEMAND</u></b>		
1.	Water demand for population is based on design guidelines		

**JABATAN BEKALAN AIR LUAR BANDAR SARAWAK**

**CHECKLIST ON DESIGN REPORT FOR WATER TREATMENT SYSTEMS**

2.	Water demand for commercial area is based on Design Guidelines.		
3.	Water demand for institutions is based on Design Guidelines.		
4.	Water demand for industrial area is based on Design Guidelines.		
5.	Fire fighting demand is based on Design Guidelines.		
6.	Allowance of 25% for non-revenue water is provided.		
7.	Allowance of 20% for treatment plant margin and usage is provided.		
8.	Is the projected total water demand acceptable?		
<b>(D)</b>	<b><u>EXISTING WATER SUPPLY SYSTEM</u></b>		
1.	Description of existing water supply system is provided.		
2.	Where the existing water supply system provides treated water, the overall layout showing the raw water intake and pumping station, water treatment plant, reservoir, etc. is provided.		
3.	Shortcomings of existing water supply such as adequacy of raw water source, treatment plant capacity, reservoir capacity and distribution system are mentioned together with proposals for short term with proposals for short term improvement works (if necessary) and also for long term solution.		
<b>(E)</b>	<b><u>RAW WATER SOURCE</u></b>		
1.	<b>Surface Water Source</b>		
	(a) Various possible options for the surface water source have been consider.		
	(b) For each raw water source option, the following information have been provided:		
	<ul style="list-style-type: none"> <li>• Hydrological data, stream flow and weather records.</li> </ul>		
	<ul style="list-style-type: none"> <li>• Safe yield including all the factors that may affect it.</li> </ul>		
	<ul style="list-style-type: none"> <li>• Safe yield is based on 7Q50 – low flow frequency analysis/River survey/rainfall-runoff modeling outcomes.</li> </ul>		
	<ul style="list-style-type: none"> <li>• Map of the water catchment (location, size, river system, land use, etc)</li> </ul>		
	<ul style="list-style-type: none"> <li>• Existing and potential sources of contamination-detailed land use map.</li> </ul>		
	<ul style="list-style-type: none"> <li>• Raw water quality Report-past records &amp; projected future status (MoH Recommended Raw Water Quality Standard).</li> </ul>		
	<ul style="list-style-type: none"> <li>• Source protection issues and measures that need to be considered or implemented.</li> </ul>		
	<ul style="list-style-type: none"> <li>• Maximum and lowest water levels (for design of intake structure and platform levels for pump house and treatment plant).</li> </ul>		

**JABATAN BEKALAN AIR LUAR BANDAR SARAWAK**

**CHECKLIST ON DESIGN REPORT FOR WATER TREATMENT SYSTEMS**

	<ul style="list-style-type: none"> <li>• Improvement requirements.</li> </ul>		
	<ul style="list-style-type: none"> <li>• Cost / benefit analysis.</li> </ul>		
	(c) Comparison of the various options for the raw water source has been carried out (should include costs advantages & disadvantages, etc.)		
	(d) For the recommended option, the reasons/justifications for selecting this option are given.		
	(e) Where run of river safe yield is insufficient, adequate impounded storage for raw water is provided.		
	(f) The safe yield of the recommended raw water source satisfied the following conditions:		
	<ul style="list-style-type: none"> <li>• Adequate to meet the maximum projected water demand while not significantly affecting the ecology of the water course downstream of the intake.</li> </ul>		
	<ul style="list-style-type: none"> <li>• Provide a reasonable surplus for anticipated growth.</li> </ul>		
	<ul style="list-style-type: none"> <li>• Adequate to compensate for all losses such as sitting, evaporation, seepage, etc.</li> </ul>		
	<ul style="list-style-type: none"> <li>• Adequate to provide ample water for other legal users of the source.</li> </ul>		
2.	<b>Groundwater Source</b>		
	a) The following information on the proposed groundwater source have been provided:		
	<ul style="list-style-type: none"> <li>• Reasons for selection.</li> </ul>		
	<ul style="list-style-type: none"> <li>• Reliable data source &amp; Elevations with respect to surrounding and flood plain(s).</li> </ul>		
	<ul style="list-style-type: none"> <li>• Geological conditions such as characteristic of formations, test holes, abandoned wells or anticipated interference between proposed and existing wells.</li> </ul>		
	<ul style="list-style-type: none"> <li>• Summary of source exploration (test well depths, location, pumping rates and their duration, water levels, specific yield, capture area and pumping radius of influence for production wells, recharge rates, etc.</li> </ul>		
	<ul style="list-style-type: none"> <li>• Raw water quality report</li> </ul>		
	<ul style="list-style-type: none"> <li>• Sources of possible contamination such as sewerage facilities, farming, burial ground, landfills, chemical facilities, etc.</li> </ul>		
	<ul style="list-style-type: none"> <li>• Feasibility of preserving existing wells and their effects on proposed wells.</li> </ul>		
	<ul style="list-style-type: none"> <li>• Depths of any known water bearing aquifers that will reduce well yield if penetrated.</li> </ul>		
	<ul style="list-style-type: none"> <li>• Wellhead and aquifer protection and management measures &amp; issues.</li> </ul>		

**JABATAN BEKALAN AIR LUAR BANDAR SARAWAK**

**CHECKLIST ON DESIGN REPORT FOR WATER TREATMENT SYSTEMS**

	b) Comparison of the various options for the groundwater source has been carried out (should include costs advantages & disadvantages, etc.)		
	c) The yield of the recommended groundwater source satisfied the following conditions:		
	<ul style="list-style-type: none"> <li>• Adequate to meet the maximum projected water demand.</li> </ul>		
	<ul style="list-style-type: none"> <li>• Provide a reasonable surplus for anticipated growth.</li> </ul>		
	<ul style="list-style-type: none"> <li>• Adequate to compensate for all losses such as seepage, etc.</li> </ul>		
	<ul style="list-style-type: none"> <li>• Adequate to provide ample water for other legal users of the source.</li> </ul>		
(F)	<b><u>RAW WATER INTAKE FACILITIES</u></b>		
1.	Locality plan showing the intake facilities is provided.		
2.	Overall layout plan showing the intake facilities is provided.		
3.	The intake is sited on a straight and stable section of the river, where erosion or deposition will not affect the intake.		
4.	The intake is sited near the treatment plant.		
5.	The intake is located upstream / not affected by any point of disposal of wastewater, and potential sources of microbiological and chemical pollution such as poultry or animal farms, graveyard, etc.		
6.	Detailed landuse map & Raw water quality analysis (MoH Recommended Raw Water Quality Standard) is provided.		
7.	Raw water quality analysis is provided		
8.	The intake is located at a place from where water level is always sufficient for abstraction even during the 1 in 50 years 7 days low flow.		
9.	The intake site is still accessible during floods.		
10.	The intake site does not accumulate debris.		
11.	The proposed location of the intake is readily accessible for operation and maintenance.		
12.	Proper access to the intake is/will be provided.		
13.	EIA to be conducted.		
14.	The design is based on site maximum and minimum water levels.		
15.	The intake structure does not obstruct the passage of vessels in navigable rivers.		
16.	The intake structure is designed to supply an evenly distributed flow to the pump suction to prevent formation of surface or submerged vortices, introduction of air into the pump, etc.		

**JABATAN BEKALAN AIR LUAR BANDAR SARAWAK**

**CHECKLIST ON DESIGN REPORT FOR WATER TREATMENT SYSTEMS**

17.	The size of the intake structure and layout of the pumps are designed to cater for future upgrading or addition of pumps to cater for increase in water demand.		
18.	The intake structure is designed to allow the pumps to achieve optimum hydraulic performance for all operating conditions.		
19.	The intake is equipped with a coarse screen and a fine screen, both removable.		
20.	The screens are readily accessible for cleaning (preferably self-cleaning)		
21.	Fenders are provided to protect the intake from floating logs, debris, etc.		
22.	Lifting hoist of adequate capacity is provided for installation and maintenance of the pumps, pipes, fittings, valves, etc.		
23.	Piling is provided.		
24.	Water proof shed is provided for switchgear, lifting hoist & other electrical equipment.		
25.	Switchgear & terminal box are sited above highest flood level possible.		
26.	<b>PONTOON INTAKE</b>		
	The design of pontoon, intake takes into account the following:		
	(i) Pontoon structure is properly designed using durable material.		
	(ii) The pumpsets can be securely mounted on the pontoon.		
	(iii) The pontoon is securely anchored without risk of overturning during changes in water level.		
	(iv) Where mooring ropes are used, they are long enough and well secured to allow for changes in water level.		
	(v) The pump's discharge pipe is long enough and well secured to allow for changes in water level. Heavy duty flexible discharge pipe of suitable material are used.		
	(vi) A housing is provided over the pump(s) and motors where centrifugal pumps are used.		
	(vii) Coarse screens are incorporated in the design of the pontoon to protect the pumps or foot valves from debris, etc.		
	(viii) Electrical cables of sufficient length are designed to allow for highest water level pontoon position.		
	(ix) Pontoon structure is properly linked with jetty accessible for operation & maintenance, including hand operated cart.		
27.	<b>JETTY INTAKE</b>		
	The design of jetty intake takes into account the following:		

**JABATAN BEKALAN AIR LUAR BANDAR SARAWAK**

**CHECKLIST ON DESIGN REPORT FOR WATER TREATMENT SYSTEMS**

	(i) The jetty is designed to meet the requirements of the appropriate design codes and standards, to sound engineering principles and is fit for the intended purposes.		
	(ii) The intake jetty is sited on stable ground which is not subjected to siltation and erosion.		
	(iii) The jetty is of reinforced concrete construction.		
	(iv) The deck of the jetty is above the maximum water level.		
	(v) The jetty is designed with platform for inspection, mounting & dismantling of raw water pumps, valves, etc.		
	(vi) Rigid pump base should be provided for installation of pumps.		
	(vii) Pump base should be sited at minimum low water level.		
	(viii) The jetty width is design for vehicle access for transporting pumps, valves, pipes, etc, during maintenance.		
28.	<b><u>SUMP INTAKE</u></b>		
	The design of the sump intake takes into consideration the following:		
	<ul style="list-style-type: none"> <li>• The sump has sufficient self-weight so that it does not float by up thrust of water.</li> </ul>		
	<ul style="list-style-type: none"> <li>• For wet sump, the width of an individual pump cell or the centre-to-center distance of two pumps if no dividing wall is used must be two times the bell diameter of the pump. (i.e.2D) (Note: <math>D = (760 \times Q)^{0.5}</math> in mm. Q = pumping rate in litres/sec)</li> </ul>		
	<ul style="list-style-type: none"> <li>• For wet sump, the distance from the pump bell centreline to the entrance of intake and location of the trash rack is five times the bell diameter (i.e. 5D)</li> </ul>		
	<ul style="list-style-type: none"> <li>• For wet sump, the distance from the pump bell centreline to backwall is 0.75D</li> </ul>		
	<ul style="list-style-type: none"> <li>• For wet sump, the distance from bottom of pump bell to the floor of sump is 0.3 to 0.5D</li> </ul>		
	<ul style="list-style-type: none"> <li>• For wet sump, the pump has a minimum submergence value as computed below: <math>S = D + (29560 \times Q) / D / 1.5</math></li> </ul>		
	<ul style="list-style-type: none"> <li>• For wet sump, the minimum water depth above floor of sump is <math>S + 0.3</math> to <math>0.5D</math></li> </ul>		
	<ul style="list-style-type: none"> <li>• The configuration of the sump floor is such that abrupt changes occur at least five bell diameters from the side of the pump.</li> </ul>		

**JABATAN BEKALAN AIR LUAR BANDAR SARAWAK**

**CHECKLIST ON DESIGN REPORT FOR WATER TREATMENT SYSTEMS**

	<ul style="list-style-type: none"> <li>The sump is designed with incoming water flowing parallel to the sump walls and directed toward the pumps inlets with a minimum of swirl.</li> </ul>		
	<ul style="list-style-type: none"> <li>The pump bay has adequate width and depth to ensure uniform and steady flow with maximum average velocities of about 0.6 m/sec. for flow into a pump station and less than 0.3 m/sec for the approach to bell mouths.</li> </ul>		
	<ul style="list-style-type: none"> <li>Pump sumps are sized and arranged to allow each pump sump to be isolated for cleaning and maintenance. A minimum of two sumps is provided.</li> </ul>		
29.	Other Items		
	(i) Stainless steel penstocks are provided for isolation of chamber		
	(ii) Desilting facilities are provided for high turbidity water		
	(iii) Any pre-sedimentation tasks required? If Yes, include desludging system, two stages pumping, etc.		
(G)	<b><u>RAW WATER /TREATED WATER (*) PUMPHOUSE</u></b>		
1.	<b><u>LOCATION &amp; SITE CONSIDERATIONS</u></b>		
	(a) Locality plan showing the pumphouse is provided.		
	(b) Overall layout plan showing the pumphouse is provided.		
	(c) The pumphouse is located on ground level which is at least 1 m. above the 100 year flood level or 1 m. above the highest recorded flood level, whichever is higher.		
	(d) The pumphouse is provided with vehicle access to allow for operation and maintenance and is accessible at all times.		
	(e) The pumphouse site is graded to divert surface water runoff away from the pumphouse and sump.		
	(f) The pumphouse site is protected from vandalism, animals or unauthorized persons using chain link fencing.		
	(g) The pumphouse site is of sufficient size and appropriate shape to allow for all equipment and any necessary maintenance and repair activities.		
2.	<b><u>PUMPHOUSE BUILDING</u></b>		
	(a) The building is of reinforced concrete construction.		
	(b) The building has outward opening doors.		
	(c) The floor of the building is at least 150mm above finished ground level.		

**JABATAN BEKALAN AIR LUAR BANDAR SARAWAK**

**CHECKLIST ON DESIGN REPORT FOR WATER TREATMENT SYSTEMS**

	(d) The floor of the building is sloped to a suitable drain so as not to endanger the quality of the water being pumped.		
	(e) A suitable outlet is provided for drainage from pump glands and priming without discharging onto the floor. Drainage sump with drainage pump for draining water must be provided for pumphouse below ground level.		
	(f) The building has adequate space for the installation of additional pumpsets that may be needed during the next 20 years with adequate space provided around each unit to allow for equipment and pump access, removal, re-installation and service.		
	(g) The pumphouse is designed to accommodate lifting hoist, hoist beams and other facilities required for lifting, removing and reinstalling of pumps, motors or other heavy equipment.		
	(h) Stairways or ladders are provided between all floors and in compartments which must be entered for operation or maintenance of the equipment. (Stairs shall be provided to areas that must be routinely entered or where supplies are transported by hand)		
	(i) The pumphouse is provided with adequate ventilation for operator comfort and dissipation of excess heat from the equipment.		
	(j) In the case of a pumphouse that is manned for extended period, the station is provided with potable water, lavatory and toilet facilities. Plumbing is so installed as to prevent contamination of the public water supply and wastes are properly discharged without causing contamination.		
	(k) Other Items		
	(i) Suction Pipes - as short as possible & minimum bends/joints. - Suction pipes for negative suction must not be shared (unlike the positive suction pipes). - sufficiently sized - Negative suction pipes do not require any sluice valves to be installed. - Foot valve is required for negative suction pipe. - No tapping points for gauges or priming line allowed for negative suction. - No mechanical flexible joints (V-J joints) for negative suction pipes.		

**JABATAN BEKALAN AIR LUAR BANDAR SARAWAK**

**CHECKLIST ON DESIGN REPORT FOR WATER TREATMENT SYSTEMS**

	(ii) The pumphouse is provided with adequate lighting so that every part of the facility is well lit and all instrument readings and all maintenance and operation can be performed without additional lighting. Light fixtures are located where bulbs can be readily changed.		
(H)	<b><u>RAW/TREATED(*) WATER PUMPING MAINS</u></b>		
1.	Layout plan of proposed pumping mains in relation to existing or proposed pipeline system is provided.		
2.	Any pipe material comparison analysis including suitability of pipe in soil & environmental conditions encountered, material & installation costs, O & M costs, etc, before selecting the pipe material to be used?		
3.	Calculation on pumping capacity, static head, friction losses and total pumping head are provided and found to be in order.		
4.	Calculation on surge analysis is provided.		
5.	Adequacy of surge vessel or surge-anticipating relief valve.		
6.	Calculations to determine the appropriate wall thickness of the pipeline are provided for cases where there are unusual external condition (e.g. depths less than 1 m. or greater than 2.5m & bridge installations), internal conditions (e.g. surge pressure) and/or use of steel or ductile iron pipe.		
7.	Can the selected pipe material and pressure rating withstand the total pumping head and the surge pressure?		
8.	Has wayleave approval for pipeline route been given?		
9.	The sizing of air valve are provided and found to be in order.		
10.	Design calculations for the anchor and thrust blocks are provided and found to be in order.		
11.	Design calculations for the piling to the anchor and thrust blocks are provided and found to be in order.		
12.	Cathodic protection is provided for steel pipelines.		
13.	Other Items		
	(a) External protection e.g. plastic sleeves are provided of DI pipelines laid in coastal area?		
	(b) Any scour/wash out provided?		
	(c) Allow flow of pipeline to be sized for future upgrading/next phase of the plant.		
	(d) The velocity of flow is within the range of 0.5 m/s to 1.5 m/s (for raw water) & max. of 2.5 m/s for distribution main.		
	(e) Flow meter is provided for measurement of raw water pumped.		

**JABATAN BEKALAN AIR LUAR BANDAR SARAWAK**

**CHECKLIST ON DESIGN REPORT FOR WATER TREATMENT SYSTEMS**

	(f) The raw water flow is 1.02 Q to 1.05 Q. 1Q = treatment capacity.		
	(g) For raw water the 'C' values in Hazen William 's formula to be used is 125-140 for plastic pipes and 90-110 for steel or ductile iron with cement mortar linings.		
(l)	<b><u>TREATMENT PLANT FACILITIES</u></b>		
1.	<b><u>LOCATION</u></b>		
	(a) Economical & Technical Criteria		
	(i) The site is optimally located in relation to the source of raw water.		
	(ii) The site is close to source of electricity supply.		
	(iii) The site is close to public access roads which enable delivery of chemicals & equipment & also facilitate construction.		
	(iv) The site facilitates the use of gravity flow which can result in lower capital & operating costs.		
	(v) The shape of the site can accommodate the plant layout and allows efficient movement of water flow between individual process units. (A rectangular-shaped area is preferred).		
	(vi) The site is optimally located in relation to the area to be served.		
	(vii) The site is relatively flat and does not require extensive cut and fill.		
	(viii) The site does not have landslide potential which require substantial site preparation and increased construction cost to protect the facilities.		
	(ix) The site sits on dense and hard soil which does not require piling or over-excavation & backfill as in the case of soft soil.		
	(x) The site does not have high groundwater levels which require dewatering during construction or require permanent dewatering to avoid permanent dewatering to avoid uplift on the structure.		
	(xi) The site does not involve extensive rock excavation.		
	(xii) The site does not require extensive storm drainage facilities		
	(xiii) The site is located above the 100 year return period flood levels.		
	(xiv) The site does not have major land issues such as high land cost, susceptibility to land disputes, etc.		
	(xv) The useable area is sufficient for the proposed treatment and future extensions of at least two more bays.		

**JABATAN BEKALAN AIR LUAR BANDAR SARAWAK**

**CHECKLIST ON DESIGN REPORT FOR WATER TREATMENT SYSTEMS**

	(xvi) The useable area has excluded wetland, streams, flood plain area and areas with landslide potential.		
	(xvii) The useable area has allowed for the required process units, roadways and operator/ maintenance facilities.		
	(xviii) Telecommunication facilities can be made available to the site.		
	(b) Environment Criteria		
	(i) The site will not have an impact on wetland due to physical modifications such as filling, draining or vegetation removal.		
	(ii) The site will not have impact on threatened or endangered species habitat.		
	(iii) The development works at the site during construction and operation will not have an impact on the surface waters such as streams and rivers.		
	(c) Community		
	(i) The site's usage is compatible with the host community by taking into account the present and anticipated future use of the surrounding areas.		
	(ii) The site does not cause displacement of housing and business.		
	(iii) The site will not have adverse impacts on the local community such as due to adour, gas emmissions, etc.		
<b>2.</b>	<b><u>SELECTION OF TREATMENT PROCESSES</u></b>		
	(a) The quality of the raw water at the proposed intake site has been studied over an extended period to ascertain the seasonal & yearly variations in the quality.		
	(b) Samples of the raw water have been collected at different times to cover the range of quality fluctuation.		
	(c) Physical, chemical & bacteriological analyses of the samples of raw water have been carried out.		
	(d) Jar tests have been carried out to determine the types and dosages of chemicals required for pre-chlorination, adsorption, coagulation, disinfection & conditioning.		
	(e) Marble tests (or calcium carbonate stability test) have been carried out to determine the alkalinity & pH which prevail at calcium carbonate equilibrium and thereby select the lime dosage required.		

**JABATAN BEKALAN AIR LUAR BANDAR SARAWAK**

**CHECKLIST ON DESIGN REPORT FOR WATER TREATMENT SYSTEMS**

	(f) Samples of the treated water obtained from the jar and marble tests are tested chemically & biologically for compliance to National Drinking Water Quality Standards.		
	(g) Based on the results of the above tests carried out, the treatment processes are selected.		
3.	<b><u>PLANT LAYOUT</u></b>		
	(a) The specific process elements and support facilities required have been identified.		
	(b) A minimum of two (2) treatment trains is provided, operating in parallel		
	(c) For a conventional water treatment plant, the following process elements & supporting facilities have been included where required:		
	(i) aerator		
	(ii) mixing flume/chamber/weir		
	(iii) flocculation tanks		
	(iv) sedimentation tanks		
	(v) filters		
	(vi) contact clear water tank		
	(vii) wash water tank		
	(viii) treated water pumping station		
	(ix) generator house/electricity supply substation		
	(x) treated high level tank		
	(xi) control building		
	(xii) chemical house		
	(xiii) operators' quarters		
	(xiv) sludge treatment facility		
	(d) A hydraulic design has been carried out to enable gravity flow from one process unit to another wherever possible.		
	(e) The various components of the treatment plant are located such that requirements for cut-and-fill or the need for elevated structures are minimized without sacrificing aesthetic requirements.		
	(f) Where the components are located on different ground levels, adequate provision has been made to protect the slope by providing close turfing, retaining walls, etc.		
	(g) All connections between the various treatment units are direct and as short as possible.		
	(h) Full consideration is given to easy inspection, operation & maintenance of the entire treatment facility by locating the process units which require more attention than others close to one another and next to the operations building.		

**JABATAN BEKALAN AIR LUAR BANDAR SARAWAK**

**CHECKLIST ON DESIGN REPORT FOR WATER TREATMENT SYSTEMS**

	(i) Adequate access to all process units equipment & for operation of all valves including adequate working area for equipment repair & maintenance are provided.		
	(j) Access & lifting devices for removal of all major equipment are provided.		
	(k) Centralized process operation & control are provided where possible.		
	(l) Adequate walkaways with a minimum width of 750mm along the filters, sedimentation tanks & flocculation basin are provided.		
	(m) Sufficient access from ground to interconnected uncovered structures is provided.		
	(n) Covered walkways are provided between process units which require greater operator's attention.		
	(o) External concrete steps or galvanized mild steel ladders are provided at convenient locations.		
	(p) Operation units such treated water pumping station & generator house are located separately from the main operations building to reduce noise problems.		
	(q) Adequate area has been allowed for future extension by at least two more bays.		
	(r) Sanitary & sludge handling facilities such as sewage pipes, septic tanks, trash pits, etc. are of watertight construction & located away from the treatment units to eliminate any potential hazards of contamination.		
	(s) The septic tank is placed at the lowest level & discharge downstream of the intake.		
	(t) Sufficient premix access roads and service roads of adequate width are provided.		
	(u) Adequate parking space for cars and motorcycles are provided for both plant operating personnel & visitors.		
	(v) Adequate landscaping is provided.		
	(w) 3 nos. of flag poles are provided for the national, State and Water Authority flags.		
	(x) Adequate drainage facilities are provided for discharge of surface water, overflows from the treatment facilities, waste washwater flows & scour flows.		
	(y) Security fencing and gates are provided.		
	(z) Adequate external lightings are provided.		
	(za) Other Items		
	(i) Safety hand rails are provided at all structures high above ground.		

**JABATAN BEKALAN AIR LUAR BANDAR SARAWAK**

**CHECKLIST ON DESIGN REPORT FOR WATER TREATMENT SYSTEMS**

	(ii) Fire protection.		
	(iii) Sludge lagoon/treatment		
4.	<b><u>OPERATIONS BUILDING</u></b>		
	(a) The operations buildings is large enough to accommodate the treatment plant staff & regular inspection & maintenance people comfortably & is commensurate with the size of the treatment plant.		
	(b) The office & meeting room (if provided) have adequate furniture and are air-conditioned for larger treatment plant.		
	(c) The mechanical and electrical spares and tools store is furnished with proper steel racks for keeping the spares & tools.		
	(d) The lobby has the following in place:		
	(i) clarity bowls		
	(ii) the main instrumentation panel		
	(iii) aquarium for monitoring water quality.		
	(e) The following are provided in the lobby or control room.		
	(i) schematic diagram		
	(ii) general layout of the treatment plant with the relevant data.		
	(f) The laboratory is provided with the following:		
	(i) purpose-built wooden cabinets for storage of chemicals & water testing equipment.		
	(ii) sufficient work benches with colour formica finish table-top complete with sinks.		
	(iii) proper water supply & drainage facilities.		
	(iv) direct sampling facilities for raw water, settled water and filtered water.		
	(v) air-conditioning.		
	(vi) Necessary laboratory testing equipment and apparatus.		
	(vii) testing reagents and tablets		
	(g) The filter operating gallery is provided with the following: -		
	(i) large clear glass aluminum casement windows & panels preferably from ceiling to floor on the side facing the filters, for easy viewing of filter operations.		
	(ii) separate operating console for each filter.		
	(iii) common dial indicators for wash water flow rate, air scour, etc. of at least 300 mm dia. or digital indicators.		
	(iv) a direct access door between the filter operating gallery and the filters.		

**JABATAN BEKALAN AIR LUAR BANDAR SARAWAK**

**CHECKLIST ON DESIGN REPORT FOR WATER TREATMENT SYSTEMS**

	(v) filter operating consoles arranged neatly and in such a manner that the operator can watch the filters washing operation easily while operating the filter consoles.		
	(h) The filter pipework gallery is provided with the following: -		
	(i) adequate ventilation & lighting.		
	(ii) adequate number of access stairs		
	(iii) adequate drainage facilities		
	(iv) minimum floor gradient of 1 in 500 sloping towards the drain pipe.		
	(v) neat arrangement of pipeworks with adequate space for easy access, installation, valves operation, inspection, maintenance or repair.		
	(vi) pipeworks are painted according to the required colour code.		
	(i) The filtered water outlet chamber has the following:		
	(i) chamber lined with white glazed tiles on the inside.		
	(ii) inspection openings with clear perspex covers.		
	(iii) vent openings to prevent water vapour collection on underside of the perspex covers.		
	(j) The following facilities are provided for the treatment plant staff and visitors:		
	(i) adequate separate toilet & bath facilities for men and ladies		
	(ii) sufficient locker facilities provided in the rest room		
<b>5.</b>	<b><u>CHEMICAL DOSING FACILITIES &amp; STORE</u></b>		
	(a) (i) The suitable types of chemicals are identified based on lab test of raw water samples.		
	(ii) Alum, lime and soda ash dosing facilities including the storage facilities are placed together in the same building but with separate distinct bay for each type of chemical.		
	(b) All chemical dosing are carried out in solution using metering pumps for plant of 1 MLD & above and by gravity for plant below 1 MLD		
	(c) Adequate working space is provided around all feeding devices so that the equipment can be maintained easily.		
	(d) Piping should be arranged to facilitate access between units and around them. Piping should be of corrosion resistant material.		

**JABATAN BEKALAN AIR LUAR BANDAR SARAWAK**

**CHECKLIST ON DESIGN REPORT FOR WATER TREATMENT SYSTEMS**

(e) Mixing tanks are of HDPE lined reinforced concrete or fibreglass lined steel tanks of Grade 316 stainless steel.		
(f) Each tank should be sized for at least 8 hours continuous operation of the plant at alum solution/soda ash solution/lime slurry of 5% strength.		
(g) All mixing tanks are provided with waist height loading platforms to facilitate discharging of chemicals by hand.		
(h) The mixing tanks & the dosing area are provided with adequate drainage & washing facilities for easy cleaning.		
(i) There is provision of chemicals storage for 3 months operation.		
(j) For all plant the components of the chemical dosing system are duplicated.		
(k) For Plants below 5 MLD, an electrically operated crane of sufficient capacity is provided.		
(l) For plants of 5MLD & above, a forklift is provided in addition to the travel crane.		
(m) For plants of 5 MLD & above, adequate aisle space is provided easy access using forklift.		
(n) The chemicals can be easily moved into storage, out of storage and to the mixing tanks on a first-in-first-out basis.		
(o) Where lime is used, the lime storage tanks are provided with adequate facilities for pumping the lime powder into the silos & to prevent caking of the lime while in storage.		
(p) Entrance to the chemical store is large enough to allow the supply truck to reverse into the building to facilitate unloading of chemicals.		
(q) A ramp is provided at the entrance for movement of the supply truck.		
(r) A top hung steel shutter door 5m wide & 2.5m high is provided.		
(s) For larger plant with big opening, electricity operated steel roller shutter door is provided.		
(t) Adequate natural ventilation is provided in the chemical store by using sufficient number of fixed louvres clear glass windows at the top.		
(u) The openings of the louvre windows are covered with mosquito-proof netting to prevent entry of birds or insets.		

**JABATAN BEKALAN AIR LUAR BANDAR SARAWAK**

**CHECKLIST ON DESIGN REPORT FOR WATER TREATMENT SYSTEMS**

	(v) Other Items - PPE are provided - Emergency eye wash and shower stand are provided at strategic locations. - Sufficient safety and hazard warning signed are provided.		
6.	<b><u>CHLORINE DOSING FACILITIES &amp; STORE</u></b>		
	(a) The chlorine dosing facilities & the chlorine store are isolated from the rest of the facilities.		
	(b) For plant of 30 MLD & above, a separate building is provided for dosing & storage of chlorine.		
	(c) Corrosion resistant materials such as plastics, fiberglass or stainless steel are used as construction material in the chlorine room.		
	(d) Hoist & other mechanical equipment are protected against corrosion.		
	(e) The chlorine dosing room & chlorine store comply with the following:		
	(i) They are of fireproof construction remote from fire risk.		
	(ii) They are located on ground floor		
	(iii) There is a minimum of two access door opening outwards.		
	(iv) Adequate extractor fans are provided, discharging outside into open space away from other facilities.		
	(v) The number & size of the extractor fans are sufficient for 12 air changes in the room per hour.		
	(vi) The extractor fans are located at near floor level with the switches installed outside the room.		
	(vii) All chlorine stores and dosing rooms are provided with chlorine leaks detectors with audible alarms located outside		
	(viii) Emergency shower facilities are provided outside the access doors.		
	(ix) For large plants, a chlorine neutralization gas scrubbing system is provided.		
	(x) The chlorine store is designed for 3 months storage.		
	(xi) (a) For small plants, storage of 68 kg. Chlorine cylinder is to be used. (b) Auto-shut down valve system is provided upon detection of chlorine leakage.		
	(xii) For plants of 30 MLD or larger, chlorine drums (916 kg capacity) are used and placed in store on concrete drum craddles.		

**JABATAN BEKALAN AIR LUAR BANDAR SARAWAK**

**CHECKLIST ON DESIGN REPORT FOR WATER TREATMENT SYSTEMS**

	(xiii) An electrically operated 2 tonne capacity gantry crane is provided for handling of the chlorine drums.		
	(v) Entrance to chlorine store should be large enough to allow the supply tank to reverse into the building to facilitate unloading.		
	(vi) Hazard warning signage is provided.		
	(vii) Duplicate chlorinators are provided.		
	(viii) Auto-change over is provided.		
<b>7.</b>	<b><u>FLUORIDE DOSING FACILITIES &amp; STORE</u></b>		
	(a) The fluoride dosing facilities and store are isolated from the rest of the facilities.		
	(b) Fluoride dosing is carried out in solution form.		
	(c) A stock tank is provided to contain 20 kg. of sodium silico-fluoride (one full bay) in solution at 0.4%.		
	(d) An additional storage tank of 2 hours retention is provided below the level of the main tank to be used to maintain supply even after the main tank is empty and to allow time to prepare the next stock solution.		
	(e) Other Items		
	(i) Duplicate fluoridator equipment are provided.		
	(ii) Dust collection system is provided.		
	(iii) Dosing equipment is provided.		
<b>8.</b>	<b><u>PRE-SEDIMENTATION</u></b>		
	(a) For raw water with high content of suspended solid, pre-sedimentation is provided.		
	(b) Design calculations are provided to show that the proposed pre-sedimentation basins are sized according to the treatment plant capacity and suspended solids content.		
	(c) The pre-sedimentation basins have hopper bottom or be equipped with mechanical moving sludge removal apparatus.		
	(d) The pre-sedimentation basins have a means of dewatering the settled sediments.		
	(e) The pre-sedimentation basins are designed such that the incoming water is dispersed evenly across the tank width to prevent short circuiting.		
	(f) There is a by-pass around each pre-sedimentation unit.		
	(g) The pre-sedimentation basins are designed with a minimum of three (3) hours detention time (actual detention time is to be determined through sedimentation tests)		
	(h) Other Items		

**JABATAN BEKALAN AIR LUAR BANDAR SARAWAK**

**CHECKLIST ON DESIGN REPORT FOR WATER TREATMENT SYSTEMS**

	(i) Duplicate pre-sedimentation basins are provided to allow 1 unit to shutdown for maintenance		
	(ii) Isolating valves are provided for shut down of 1 unit for maintenance.		
<b>9.</b>	<b><u>AERATION</u></b>		
	(a) Aeration is used because of the following based on the results of the raw water quality:		
	(i) To help remove taste & odour.		
	(ii) To remove volatile organic matter		
	(iii) To remove carbon dioxide		
	(ix) To assist in iron and/or manganese oxidation.		
	(b) One of the following types of aerator is used with justifications provided:		
	(i) Gravity or cascading aerator.		
	(ii) Fountain aerator.		
	(iii) Diffused or injection aerator.		
	(iv) Mechanical aerator		
	(c) For water into air type of aeration using cascade or tray aerators, the distribution of water is uniform over each tray.		
	(d) For spray aerator, the following are in place:		
	(i) The hydraulic head is sufficient		
	(ii) The sizes, number and spacing of the nozzles are properly designed based on the flow rate, space and amount of head available.		
	(iii) There is an enclosed basin to contain the spray.		
	(iv) Design calculations are provided.		
	(e) The aerator is constructed of durable material resistant to aggressiveness of water & dissolved gases.		
<b>10.</b>	<b><u>MIXING</u></b>		
	(a) One of the following types of mixer is used with justifications provided:		
	(i) mixing flume		
	(ii) weir		
	(iii) flash mixer		
	(iv) mechanical mixer		
	(b) Mixing Flume		
<b>11.</b>	<b><u>FILTERS</u></b>		
	(i) General requirement for design of filter such as follows:		
	(a) Filtration rate (5 m <sup>3</sup> /m <sup>2</sup> /hr)		
	(b) Length and breadth ratio		
	(c) Size of filter		
	(d) Tank depth		
	(e) Free board		

**JABATAN BEKALAN AIR LUAR BANDAR SARAWAK**

**CHECKLIST ON DESIGN REPORT FOR WATER TREATMENT SYSTEMS**

	(f) Water depth		
	(g) Loss of head		
	(h) Media depth (0.6-1.0m)		
	(ii) To provide the filter pipes sizing		
	(iii) To provide the recommended flow velocity of the pipe and channel.		
	(iv) To provide the design requirement for filter backwash systems such as below:		
	(a) Separate air & water wash		
	(b) Combine air & water wash.		
	(v) Summary of the results for design of filter such as follows:		
	(a) Number of filter used.		
	(b) Settle water inlet pipe diameter		
	(c) Filtered water outlet pipe diameter		
	(d) Air scour inlet pipe diameter		
	(e) Backwash water diameter		
	(f) Filter washout pipe diameter		
	(g) Air blower capacity		
	(vi) All design calculations for the sizing of the filters are to be provided.		
	(vii) Filter underdrain system design is provided – (a) No. & type of nozzles (b) Spacing (c) type of underdrain (lateral manifold system or false bottom)		
	(viii) Filter media is acceptable.		
	(vix) Filter floors are designed to sustain the entire weight of the filter media.		
	(x) Filter floors are designed to withstand the upthrust of the backwashing water.		



**JABATAN BEKALAN AIR LUAR BANDAR (JBALB) SARAWAK**

**TESTING AND COMMISSIONING DOCUMENT**

**FOR**

**BOOSTER PUMPING STATION**

..... **DIVISION**

**CONTRACT NO: .....**

## TABLE OF CONTENTS

<u>No.</u>	<u>Description</u>	<u>Pages</u>
1	Pre-requirement for Document Submission Prior to Testing & Commissioning Activity	1
2	Process flow for Commissioning of Booster Pump Station Methodology	2
3	Method Statement - Booster Pump Station Pre & Post Commissioning	8
4	Guidelines and Checklist for Full Testing & Commissioning of Booster Pump Station	11
5	General Notes for Pre-commissioning, Commissioning and Acceptance Test for Booster Pump Station	12
6	Commissioning Checklist for Booster Pump Station	17
7	Acceptance Tests for Treatment Works	23
8	Table A : Pump Monitoring Table	27
9	Table B : Pump Test Certificate	28
10	List of Equipment	29
11	Appendix (A) Pre-commissioning Checklist for Booster Pump Station	32

	<b>TESTING AND COMMISSIONING DOCUMENT FOR BOOSTER PUMPING STATION</b>	Contract No:
		Rev: 1
		Date:

**PRE-REQUIREMENT FOR DOCUMENT SUBMISSION PRIOR TO  
TESTING & COMMISSIONING ACTIVITY**

No	Item	YES	NO	N/A	REMARKS
1	Method Statement Of T&C				
2	Operation & Manual (O&M)				
3	Factory Acceptance Test Report (FAT)				
4	Site Acceptance Test Report (SAT)				
5	Testing and Commissioning checklist				
6	QAQC check records documentation review before Testing and Commissioning (T&C) but not limited to: I. Equipment data sheet II. Equipment manufacture test certificate III. Instrument/Equipment calibration certificate IV. As build Drawing ➤ Mechanical & Electrical ➤ Civil & Structure				
7	Site walk/Inspection prior to readiness of T&C				
9	Training on equipment in regards to safety, operating, maintenance and emergency practice/ procedure				
10	Punch list closed – if any				
11	Non Conformance Report (NCR) closed – if any				

Above requirement shall be submitted **2 weeks** before T&C except FAT report:

	<p>TESTING AND COMMISSIONING DOCUMENT FOR BOOSTER PUMPING STATION</p>	Contract No:
		Rev: 1
		Date:

**PROCESS FLOW FOR COMMISSIONING OF  
BOOSTER PUMPING STATION**

	<b>TESTING AND COMMISSIONING DOCUMENT FOR BOOSTER PUMPING STATION</b>	Contract No:
		Rev: 1
		Date:

## COMMISSIONING OF NEW JBALB BOOSTER PUMPING STATIONS

### 1.0 Commissioning Team

The commissioning of all new Booster Pump Stations shall be carried out by designated officers coordinated from Jabatan Bekalan Air Luar Bandar (JBALB) Headquarters. The commissioning team shall consist of the following: -

#### 1.1 JBALB Headquarters

- a) Mechanical Engineer
- b) Electrical Engineer
- c) Civil Engineer (Related Project)
- d) Chemist
- e) Assistant Engineer

#### 1.2 JBALB Divisional

- a) Divisional Water Engineer (DWE)/ Officer Incharge of Division (OIC)
- b) Assistant Engineer, J29

#### 1.3 JBALB Project Management Team

- a) Divisional Water Engineer (DWE)/ Officer Incharge of Division (OIC).
- b) Assistant Engineer, J29

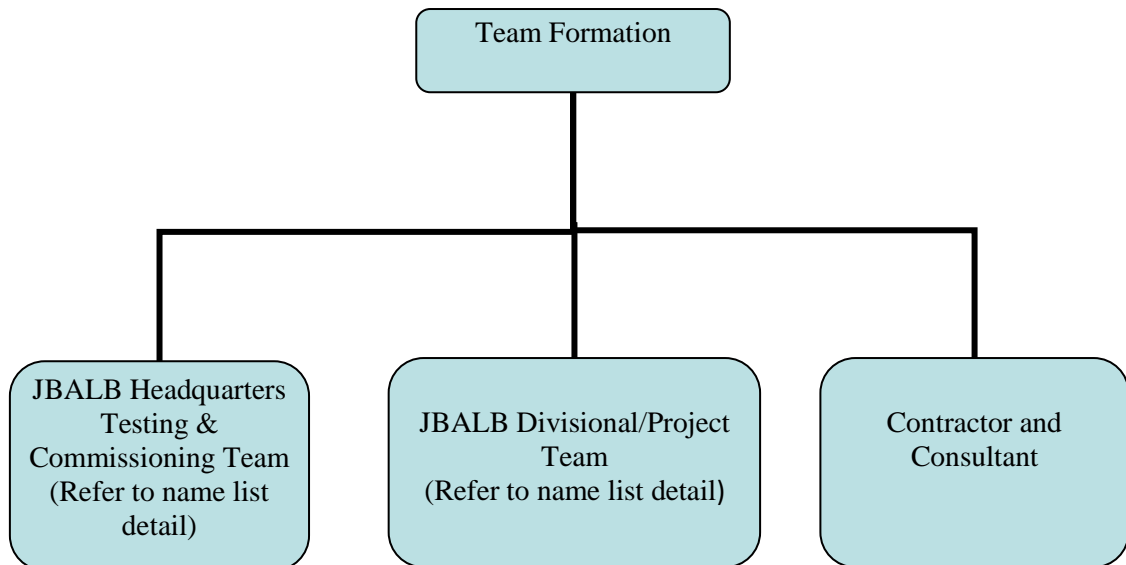



**TESTING AND COMMISSIONING  
DOCUMENT FOR BOOSTER  
PUMPING STATION**

Contract No:

Rev: 1

Date:

**2.0 Methodology**

2.1 The Mechanical Engineer from JBALB Headquarters will head the commissioning team and the Divisional Water Engineer (DWE), Assistant Engineer and Assistant Technician/Technician are allocated the following tasks to assist in the commissioning.

2.2 Pembantu Kemahiran H17 & Pembantu Awam H11/14 will assist the commissioning teams and will take over the plant operation after successful commissioning and handing over. In this respect, they will get hands-on experience in the plant operation.

2.3 Project Management Team from JBALB Divisional/Regional Office's role is to be the coordinator to instruct consultant/contractor to execute and implement the commissioning process as per guidelines and checklist. They are responsible to coordinate with JBALB Headquarters Commissioning Team to ensure that proper guidelines and procedure is implemented prior to the commissioning of Booster Pump Station are in accordance with the guidelines before handing over to JBALB Division.

**PRE-COMM/COMMISSIONING  
PROCESS (Booster Pump Station)**

**PRE-COMMISSIONING PROCESS**

What to check?

Physical and visual check of control equipment i.e. Pumps, Valves, PLC's, Genset, MSB, etc. as per Guidelines of Pre-Commissioning Checklists & Contract Document.

**COMMISSIONING PROCESS**

What to check?

Individual System Checks as per Guidelines of Commissioning Checklists and Data Sheets.

*Commissioning  
successful*

**DOCUMENTATION / HANDOVER**

Parties involved: Divisional Office and JBALB Headquarters

**REFRESHER/ TRAINING**

- As per contract (external)
- To be conducted by JBALB Divisional and JBALB HQ (recommended once every six (6) month)

	<b>TESTING AND COMMISSIONING DOCUMENT FOR BOOSTER PUMPING STATION</b>	Contract No:
		Rev: 1
		Date:

### **3.0 Tasks and Duties**

- i) The commissioning team will witness the testing of all items of equipment, pipework, fittings and appurtenant (accessories) works to ensure that they are correctly installed and capable of proper operation.
- ii) The team will witness start up and running each item of equipment separately until they are satisfied that it is capable of proper operation.
- iii) After each item of equipment has been tested separately, the various items will be run concurrently to commission the plant.

#### **3.1 In carrying out (i) to (iii) above, the team shall ensure that: -**

- i) The correct sequence of operation of the plant is checked and documented.
- ii) Plant control systems are checked.
- iii) Calibration on Testing and Measuring tools is carried out.
- iv) Switchboards, control panels, alarm systems, overloads, and safety equipment are tested.
- v) The alignment, mounting and configuration of pumps and drives, including the direction of rotation are checked.
- vi) The various lubrication systems and greasing systems are checked, including pump shaft lubrication and stuffing box seal requirements.
- vii) The pipework valves and gauges are correctly installed and operate satisfactorily. The appropriate valve positions shall be determined for the different modes of operation of the plant and documented.
- viii) The chemical mixing, feeding and dosing equipment shall be tested and calibrated.
- ix) Load tests are carried out on lifting equipment.
- x) The necessary chemical testing equipment is provided and in working order.
- xi) All other tools and equipment necessary have been provided and are in working order.

	<b>TESTING AND COMMISSIONING DOCUMENT FOR BOOSTER PUMPING STATION</b>	Contract No:
		Rev: 1
		Date:

### 3.2 During the commissioning of the plant, the team shall ensure that: -

- i) The limits of hydraulic operation of the various units of the plant are determined.
- ii) The appropriate flow rate through the plant is determined to minimize “on-off” operation. Guides on pumping rates for the raw water and treated water pumps shall be established.
- iii) The clarifiers are operated with the appropriate level of coagulant to achieve a well developed floc blanket.
- iv) The rate of desludging of the clarifiers is determined.
- v) The filters are operated sufficiently long to establish head loss characteristics and backwash requirements.
- vi) The filter backwash system and air scour are operated correctly. The correct procedure for backwashing of the filters is determined and documented.
- vii) As far as possible, the appropriate levels of dosing of chemicals for the plant are determined. In particular, the appropriate level of post dosing for pH correction is determined.

### 3.3 Documents and operation manuals

The following documents shall form part of the commissioning:

- i) JKR MS ISO 9001 Quality Procedures on Water Treatment Process;
- ii) Buku Panduan Kerja Pertukangan Atenden Loji Bekalan Air;
- iii) Buku Panduan Kerja Pertukangan Atenden Pam Bekalan Air;
- iv) Buku Panduan Kerja Pertukangan Atenden Enjin Bekalan Air;
- v) Perintah-Perintah Tetap Pihak Berkuasa Bekalan Air JKR;
- vi) Other operation manuals for the pumps and equipment.

### 3.4 Refresher/Induction Training

During the commissioning of the plant, the Divisional Water Engineer (DWE), Assistant Engineer, Assistant Technician/Technician and attendants allocated to assist the teams, will undergo “hands on” training in preparation for accepting responsibility for operation of the plant. This training role will be a significant aspect of the duties of the commissioning team.

	<b>TESTING AND COMMISSIONING DOCUMENT FOR BOOSTER PUMPING STATION</b>	Contract No:
		Rev: 1
		Date:

### 3.5 Handing Over and Documentation

3.5.1 When the plant is operating satisfactorily and treated water has been supplied into the existing reticulation system, it will be handed over to the JBALB Division staff.

3.5.2 The commissioning team will prepare four (4) copies of the commissioning report, (1) one copy to the Regional Manager, (1) one copy to the Divisional Water Engineer and (2) two copies to JBALB Headquarters.

3.5.3 The report shall contain as a separate section, the recommended procedure for operating the various items of the plant including the following:

- i. Valve on-off schedules
- ii. Switchboard operation and use of control panels and monitors.
- iii. Observed rate of desludging of clarifiers and backwashing of filters.
- iv. Operation of the raw water pumps and clear well pumps to integrate the plant into the existing system and optimize its operation.

3.5.4 An assessment of the induction training of operator staff shall be given.

	<p><b>TESTING AND COMMISSIONING DOCUMENT FOR BOOSTER PUMPING STATION</b></p>	Contract No:
		Rev: 1
		Date:

**METHOD STATEMENT  
BOOSTER PUMP STATION PRE & POST COMMISSIONING**

	<b>TESTING AND COMMISSIONING DOCUMENT FOR BOOSTER PUMPING STATION</b>	Contract No:
		Rev: 1
		Date:

### METHOD STATEMENT

#### Booster Pump Station Pre & Post Commissioning

#### Background Information

Project Name	
Contract No.	

#### Pre & Post Commissioning Implementation

Divisional Involvement	<ol style="list-style-type: none"> <li>1. Divisional Office representative shall be present during pre-commissioning and commissioning stage to witness and comment any dissatisfaction /query through Project Management Team / Commissioning Team representative.</li> <li>2. Divisional Office representative shall be at least Assistant Engineer, J29 of Mechanical or Electrical to be involved during pre-commissioning and commissioning stage (especially M&amp;E equipment testing).</li> <li>3. Booster Pump Station Operator shall be involved during system operational testing for the purpose of familiarization of new booster pump station. Certificate of Practical Completion (CPC) shall be to the satisfaction of JBALB Commissioning Team and JBALB Divisional Office SO/SOR/OIC. This is to ensure proper handing over and operational needs are met and achieved as per design in the Contract.</li> </ol>
New Pipe interconnection to existing piping system	<ol style="list-style-type: none"> <li>1. JBALB Project Management Team concerned shall notify any pipe interconnection and submit method statement for interconnection work to JBALB Divisional Office prior to the commencement of actual work.</li> <li>2. Method statement must be agreed between Project Management Team and Respective JBALB Divisional Office before any work can proceed.</li> <li>3. Upon agreement on the interconnection Method Statement, the affected Divisional Office (DWE/OIC) shall issue notice of water supply interruption to the public prior to the execution of interconnection work either via Corporate Communication or Information Department (which ever) is more efficient and cost effective within a weeks notice.</li> <li>4. Any actual shutdown to the existing system shall be done by representative from JBALB Divisional Office assisted by the Contractor involved.</li> <li>5. The interconnection work and any reinstatement work which is affected by the interconnection process shall be done by the contractor involved to the satisfaction of representative of both Project Team and Divisional Office.</li> </ol>
Consumables Requirement	<ol style="list-style-type: none"> <li>1. After every successful Testing and Commissioning, it is crucial that the Appointed Contractor/Consultant prepare</li> </ol>

	<b>TESTING AND COMMISSIONING DOCUMENT FOR BOOSTER PUMPING STATION</b>	Contract No:
		Rev: 1
		Date:

	<p>and advice on the usage and quantity of consumable chemical required such as; chlorine, aluminum sulphate, polymer and soda ash shall be made available as stock for at least 3 to 6 months (subject to availability &amp; plant locality) for operational use after project completion (CPC).</p> <ol style="list-style-type: none"> <li>2. It is recommended that the information on where and how to acquire these required consumable shall be made known to the JBALB Divisional Office for reference of their planning and procurement process by the users.</li> <li>3. Material acquisition inclusive of M&amp;E parts shall be identified and JBALB Divisional Office is recommended to acquire major parts for major pumps and dosing pump for stock in advance for the ease of maintenance after the end of Defect Liability Period (DLP).</li> </ol>
<p>Recommendation on Operational and/Or Overall Maintenance Plan</p>	<ol style="list-style-type: none"> <li>1. Operation and maintenance manual for the booster pump station shall be provided by the contractor to the JBALB Divisional Office and JBALB Headquarters for references on operational matters.</li> <li>2. JBALB Divisional Office shall produce the Maintenance Plan which include periodic and preventive/predictive maintenance of all major equipment i.e. booster pump, control panels, generator set. It is recommended that all major equipment is checked and inspected at a regular interval of three (3) months (minimum) by Audit or representatives from JBALB Headquarters.</li> <li>3. JBALB Divisional Office shall coordinate with JBALB Headquarters regarding procedure, schedule and costing for maintenance of all equipment. It is advisable that this coordination is initiated prior to the end of project's DLP.</li> </ol>
<p>Recommendation on manpower requirement for new Booster Pump Station (BPS)</p>	<ol style="list-style-type: none"> <li>1. It is recommended that DWE/OIC's to review their current operation setup and manpower requirement to suit the new BPS prior to the completion of the project.</li> <li>2. For the operation of BPS, additional manpower should be allocated sufficiently to oversee the operation of isolated BPS. This would help to avoid or reduce the occurrence of vandalism especially to this isolated BPS. Any failure at this BPS will jeopardize the reliability of water supply to which the BPS cater.</li> </ol>

	<p>TESTING AND COMMISSIONING DOCUMENT FOR BOOSTER PUMPING STATION</p>	Contract No:
		Rev: 1
		Date:

**GUIDELINES AND CHECKLIST FOR FULL TESTING & COMMISSIONING  
OF BOOSTER PUMP STATION**



TESTING AND COMMISSIONING  
DOCUMENT FOR BOOSTER PUMPING  
STATION

Contract No:

Rev: 1

Date:

*General Notes for Pre-commissioning,  
Commissioning and Acceptance Test  
Booster Pump Stations*

	<p>TESTING AND COMMISSIONING DOCUMENT FOR BOOSTER PUMPING STATION</p>	Contract No:
		Rev: 1
		Date:

**GENERAL NOTES FOR  
PRE-COMMISSIONING, COMMISSIONING AND ACCEPTANCE TESTING  
OF BOOSTER PUMP STATIONS**

The following notes are intended as a guide to the completion of Pre-Commissioning and Commissioning Works in a manner which will be consistent throughout all new Booster Pump Stations.

**Guidelines and Checklist for Pre-commissioning (Appendix A)**

These are checks which are required to be undertaken by the Mechanical/Electrical Sub-Contractor and are supervised by Contractor's staff. They are intended as a virtual 'check list' to ensure that all items of equipment have been installed according to manufactures/supplies requirement and have been prepared for commissioning/operation.

**Guidelines and Checklist for Commissioning**

These are checks which are required to be undertaken by Contractor's staff in the presence of Jabatan Bekalan Air Luar Bandar (JBALB) staff.

It is essential that JBALB staffs are present in order to witness measurements, readings, and observations made during these checks. For this reason, sufficient notice should be given by Contractor to JBALB (UPT). **The contractual requirement is for 21 days' notice.** It is possible however, to advise late changes to programme by facsimile/telephone when absolutely necessary.

Guidelines and Checklist for Commissioning are intended to be applicable to ALL Booster Pump Stations. It is unavoidable, therefore, that certain sections will not be applicable to a particular scheme. Inapplicable sections will normally have been crossed out or struck through before the time of commissioning. If this is not the case, then a comment should be made by the signatories indicating which sections have not been undertaken or witnessed.

It is absolutely essential that Mechanical and Electrical competent personnel are delegated to witness the commissioning of Mechanical and Electrical equipment in order to avoid protracted discussions and arguments on methods/techniques employed to generate the data.

	<p>TESTING AND COMMISSIONING DOCUMENT FOR BOOSTER PUMPING STATION</p>	Contract No:
		Rev: 1
		Date:

**Specific Guidance: Pre-Commissioning / Commissioning**

1. *Check pumps stop when reservoir full.....*

If the reservoir is greater than 1 km-from the Booster Station, pumps are stopped by a differential pressure switch which is operated on a decrease in flow. It may not be convenient to wait for what could amount to several hours in order to demonstrate the correct operation of this cut-out. All that is necessary in this case is to slowly close the pump discharge valve and note the flow at which the pump trips.

For reservoirs less than 1 km from the Booster Station, pumps are stopped by level electrodes which respond to the conduction of an electric current between them (when both are immersed in water). Again, correct operation can be demonstrated by lowering the High Level electrode into the water, or by shorting the Reference and High Electrodes momentarily.

2. *Check pumps restart automatically.....*

If a low flow trip, then re-start is by an adjustable timer. All that is necessary in this case to demonstrate correct operation, without having to wait for an excessive time, is to temporarily adjust the timer to a value of a few minutes.

Where trip is by electrode, re-start is also by electrodes, in this case by a break in the flow of electric current between them. (When the water level falls below the Low Level Electrode) Correct operation can be demonstrated in this case by raising the Low Level Electrode clear of the water surface, or by momentarily disconnecting the connection to the Low Level Electrode.

3. *Check pumps stop when suction tank is at low level; Check pumps re-start automatically.....*

In the case of a suction tank, trip and re-set are both by electrode and the same comments made above apply here. In some situations, however, where there is uncertainty as to the precise details of existing water reservoirs, it will be necessary to check correct tripping by draining or drawing down the feed reservoir.

4. *Motor rated speed + measured speed*

This is determined by either an optical or a contact tachometer.

	<p>TESTING AND COMMISSIONING DOCUMENT FOR BOOSTER PUMPING STATION</p>	Contract No:
		Rev: 1
		Date:

5. *Travelling Crane*

The JKPP Certificate for the crane should be issued and available for record.

6. *Surge Suppression Equipment.*

After the surge suppression equipment is commissioned, all that is required under this section is to observe the maximum and minimum pressures indicated on the surge arrestor pressure gauge on starting and stopping the pump from a position of pressure equilibrium. The JKPP Certificate for the Surge Suppression Equipment should be issued and available for record.

7. *Generating Sets*

Department of Environment (DOE) Approval Certificate for installation of Generating Set should be issued and available for record.

8. *Fire Protection System*

Bomba Approval on all Fire Protection System should be issued and available for record.

9. *Chlorination System*

To check whether chlorination system synchronizes with booster pump or not.

Table A - Pump Bearings/Vibration

Correct operation of pumps can only be assessed by mechanically competent and experienced personnel. Manufacturers' literature states that bearing temperature should check by hand: If a normal person can hold a bearing cover without feeling pain, then it is highly probable that the temperature is below 60 degree C and that the bearing is running normally.

If the bearing is running hot, this does not necessarily mean that it is defective, in nine cases out of ten it is usually found that it has been over packed with grease, and that cleaning and repacking the bearing will reduce its operating temperature.

'Abnormal' noise and vibration is a very subjective assessment and again, should be left to experienced personnel.

Table B - Pump Test Sheet

Readings are taken over the operating range of the pumps. Data are calculated and graphs drawn SUBSEQUENT to the commissioning of the booster stations. JBALB personnel/representative should witness the readings taken. There will be one TABLE A, and one TABLE B for each pump set.

	<p>TESTING AND COMMISSIONING DOCUMENT FOR BOOSTER PUMPING STATION</p>	Contract No:
		Rev: 1
		Date:

### Guidelines for Acceptance Test

Most of the data entered onto the Acceptance Test Guidelines will be abstracted from the Pre-Commissioning and Commissioning Guidelines. The main purpose of the acceptance test is to demonstrate the system as a whole will function satisfactorily over a period of 14 days (or less depending upon the operational requirements of JBALB).

All that is required is for JBALB representatives to acknowledge the period of operation defined as the 'Acceptance Test'.

N.B. JBALB representatives are not being asked to 'accept' or takeover schemes. All that is required of them is to witness the proceedings and if necessary, to draw up a 'snag list' of items considered incomplete or defective. This snag list, together with any comments considered appropriate, should be referred to JBALB Divisional who are the agency responsible for accepting schemes.

	<p>TESTING AND COMMISSIONING DOCUMENT FOR BOOSTER PUMPING STATION</p>	Contract No:
		Rev: 1
		Date:

COMMISSIONING CHECKLIST FOR BOOSTER PUMPING STATION

COMMISSIONING CHECKLIST FOR BOOSTER PUMPING STATION



**TESTING AND COMMISSIONING  
DOCUMENT FOR BOOSTER PUMPING  
STATION**

Contract No:

Rev: 1

Date:

**COMMISSIONING CHECKLIST FOR BOOSTER PUMPING STATION**

Project Name .....	Pump Type.....	
Work Contract No. .....	Serial Nos.	PUMP .....
Booster Stations .....		PUMP .....
Name & Location .....		PUMP .....
		PUMP .....
<b>1. REFERENCE DOCUMENTS</b>	Compliance checked by Consultant	
Location Plan		
Scheme Specific		
Pipeline Profiles		
Booster Station Assembly drawings		
Manufacturers Pump set test cert. (attached)		
O&M manual (draft)		
<b>2. PUMPS</b>	Checked by Consultant	Witnessed by JBALB Representative
a) Refer to Operation & Maintenance Manual (2.2.5 Operating Procedure - Booster Pump. Station)		
b) Run each pump for 2 hours or until Bearing temperature is constant. Check Bearing temperature in motor and pump, noise, vibration and gland leakage (see table. A, Data Sheet)		
c) Take readings at approximately 25%, 50% and 100% Discharge valves open condition (see table B, Data Sheet)		
d) Check pumps stop when reservoir-full		
	Actual level:	m
e) Check pump re-starts automatically		
	Actual level:	m

	<b>TESTING AND COMMISSIONING DOCUMENT FOR BOOSTER PUMPING STATION</b>	Contract No:
		Rev: 1
		Date:

**COMMISSIONING CHECKLIST FOR BOOSTER PUMPING STATION**

f) Check pumps stop when suction tank is at low level				
	Actual level:		m	
g) Check pumps re-start automatically after 1 hour (if water is available)				
	Actual level:		m	
<b>3. MOTORS</b>	PUMP	PUMP	PUMP	PUMP
a) Rated speed (rpm)				
Measured speed.(rpm) (full load)				
<b>4. OVERHEAD TRAVELLING CRANE</b>			Yes	No
a) Alignment check complete				
b) Manufacturers test certificate attached				
Vertical Deflection test of crane bridge caused by hoist plus SWL in central Position	Span	Def		
Permitted max. def. (Span - 750)			Def	
d) Load hook through full travel				
e) Crane travelled full length with Safe Working Load (SWL)				
f) JKKP type approval				
g) JKKP installation approval & Certificate (See Attached Certificate)				
<b>5. DIESEL GENERATOR SET</b>				
a) Manufacturers Test Certificate attached				
b) D.O.E. Application				
c) Factory Acceptance Test (FAT) attached				
d) Oil pressure switch operation	Rated	Actual		
	kPA	kPA		
e) Water temperature switch operation	°C	°C		
f) Engine over speed switch operation	rpm	rpm		

	<b>TESTING AND COMMISSIONING DOCUMENT FOR BOOSTER PUMPING STATION</b>	Contract No:
		Rev: 1
		Date:

**COMMISSIONING CHECKLIST FOR BOOSTER PUMPING STATION**

g) Trip-on control circuit voltage failure				
h) Noise measurement (dBA) Measured 3 m from exhaust Measured 3 m from outer wall	North	South	East	West
i) Test generator over six consecutive starts			Yes	No

**6. SURGE SUPPRESSION EQUIPMENT**

(Where Surge Suppression Equipment fitted, commissioning will be carried out under section 2)

a)	Pump start up:	Observed pressure	Max.	Min.
	Pump shut down:	Observed pressure	Max.	Min.
			Pressure Set Point:	Bar
			Level Set Point:	M

**7. CHLORINE DOSING SYSTEM**

Check all gas pipework joints for leaks using ammonia vapor.

Manufacturers pre-start up checks complete		Yes	No
Satisfactory	Unit	Yes	No
	Chlorine Dosing		
	Chlorine Dosing		
	Chlorine Dosing		
Check operation changeover panel.			
Commissioning complete, system ready for use.		<b>Yes</b>	<b>No</b>

Remarks:

	Checked By Contractor	Certified by Consultant	Witnessed by JBALB Representative
Name			
Signature			
Designation			
Date			





TESTING AND COMMISSIONING  
DOCUMENT FOR BOOSTER PUMPING  
STATION

Contract No:

Rev: 1

Date:

COMMISSIONING CHECKLIST FOR BOOSTER PUMPING STATION

Work Contract No. :	Operation :	hr/d
---------------------	-------------	------

2. ANALOG INPUT/OUTPUT SIGNAL TO/FROM SCADA (PLC LOGIC TEST)

PROCEDURE

1. Determine the loop is internally powered or externally powered from the schematic diagram.
2. Connect the + and – wires of the signal injector to the 4-20mA input terminals at...(Station Name).....Panel and set the signal injector according to the loop power condition.
3. Simulate the signal to 0%, 25%, 50%, 75%, 100% of the instrument range.

TEST CRITERIA

- The SCADA shall give the output signal according to signal simulated.

Equip. Description :  
Simulated Range : 4 – 20 mA  
Input Range :

	Simulated Range (mA)	Desired Value	Displayed Value	Remarks
	4			
	8			
	12			
	16			
	20			

Commissioning complete systems ready for use.

Remarks:

	Checked by Contractor	Certified by Consultant	Witnessed by JBALB Representative
Name			
Signature			
Designation			
Date			

	<p>TESTING AND COMMISSIONING DOCUMENT FOR BOOSTER PUMPING STATION</p>	Contract No:
		Rev: 1
		Effective date: 3 <sup>rd</sup> February 2020

ACCEPTANCE TEST FOR BOOSTER PUMP STATION

ACCEPTANCE TEST FOR BOOSTER PUMP STATION



TESTING AND COMMISSIONING  
DOCUMENT FOR BOOSTER PUMPING  
STATION

Contract No:

Rev: 1

Effective date: 3<sup>rd</sup> February  
2020

ACCEPTANCE TEST FOR BOOSTER PUMP STATION

Project Name .....

Work Contract No. ....

1. Design Assumption: (See attached sheet)
2. Start Date for Test:
3. JBALB Required From:
4. JBALB State Representative Required for JBALB Valve/Filling  
Operation From: ..... to .....

5.	Disinfection successfully completed:	Pipelines	
		Surge Vessels	
		Suction Tank	
		Reservoirs	
6.	Equipment used for measurement	Pipelines	Tanks
	Flow		
	Range of flowmeter		
	Head loss through flowmeter		
	Comments		
	Pressure		
	Range of instrument		
	Comments		
	Level		
	Comments		



TESTING AND COMMISSIONING  
DOCUMENT FOR BOOSTER PUMPING  
STATION

Contract No:

Rev: 1

Effective date: 3<sup>rd</sup> February  
2020

ACCEPTANCE TEST FOR BOOSTER PUMP STATION

7. CRITERIA FOR PASSING TEST

Booster Station Name:

Operating hours:

hr/day

Start pumping:

Stop pumping:

\* These are shift times. The pump will stop and start during this period if the Storage Reservoir fills.

Required output: 1.1 times Average Daily Year 2000 Flow

$$= 1.1 \times \text{_____} = \text{_____}$$

8. Pipelines

Year 2000  
Flow\*

Flow  
Measured

Required  
Pressure

Recorded  
Pressure

\* or highest available flow (see attached graph)

9. Reservoir Name

Overflow measured at full pump output (outlet valve closed,  
inlet valve held open)

Bypass flow (if applicable)

Required year 2000 inflow

Actual max. pumped inflow

Peak outflow measured



TESTING AND COMMISSIONING  
DOCUMENT FOR BOOSTER PUMPING  
STATION

Contract No:

Rev: 1

Effective date: 3<sup>rd</sup> February  
2020

ACCEPTANCE TEST FOR BOOSTER PUMP STATION

10. Test conducted for 14 days/ ..... (OR as agreed with JBALB)			
11. OVERHEAD CRANE			
JKKP Approval Required If Yes, JKKP Certificate If No, JBALB Approval At Commissioning	Yes	No	
12. DIESEL GENERATOR SET			
D.O.E Approval	Yes	No	
13. SURGE SUPPRESSION EQUIPMENT			
JKKP Type Approval JKKP Installation Approval	Yes	No	
14. CHLORINE DOSING SYSTEM			
Functioning in line with booster pump	Yes	No	
Remarks:			
	Checked By Contractor	Certified by Consultant	Witnessed by JBALB Representative
Signature			
Name			
Designation			
Date			





## LIST OF EQUIPMENTS

<b>1.</b>	<b>Treated Water Pump</b>					
	Pump Brand/Make					
	Pump Model					
	Pump Serial No.					
	Pump Head	m				
	Design Flow Rate	m <sup>3</sup> /hr				
	Horsepower	HP				
	Power	kW				
	Rated current	A				
	Voltage/Phase	V/Phase				
	Motor Brand/Make					
	Motor Model					
	Motor Serial No.					
	Motor Speed	rpm				
	Motor Frequency	Hz				
	Class					

<b>2.</b>	<b>Chlorination System</b>					
2.1	<i>Vacuum Regulator</i>					
	Brand/Make					
	Type					
	Model					
	Heater Make					
	Heater Type					
	Power Rating	V/A/W				
	Rated Frequency	Hz				
2.2	<i>Chlorinator</i>					
	Brand/Make					
	Type					
	Model					
	Max Capacity	kg/hr				
	Motor Make					
	Motor Type					
	Power Rating	V/A/W				
	Rated Frequency	Hz				
2.3	<i>Changeover Manifold</i>					
	Brand/Make					
	Type					
	Serial No.					
	Range					
2.4	<i>Injector</i>					
	Brand/Make					
	Type					
	Serial No.					
	Max Capacity	kg/hr				

<b>3.</b>	<b>Pressure Transmitter</b>					
	Instrument Brand/Make					
	Instrument Model					
	Instrument Serial No.					
	Measure (i.e. pH, NTU,mg/l)					
	Output current	mA				
	Rated current	A				
	Voltage/Phase	V/Phase				
	Rated Frequency	Hz				
	Class					
<b>4</b>	<b>Crane</b>					
	Brand/Make					
	Type					
	Model					
	Country					
	Year					
	Equipment Serial No.					
	Hoist Serial No.					
	PMA Registration No.					
	Hoisting Capacity	Ton				
	Voltage/Phase/Current	V/Phase/ A				

5.	<b>Surge Vessel (If Applicable)</b>					
	5.1	<i>Compressor</i>				
		Brand/Make				
		Model				
		Serial No.				
		Piston Displacement				
		Max Discharge Pressure	Bar			
		Design Duty Pressure	Bar			
		Free Air				
		Noise Level	dB			
5.2	<i>Motor</i>					
		Brand/Make				
		Type				
		Model				
		Serial No				
		Power	kW			
		Voltage/Phase	V/Phase			
		Rated Current	A			
		Speed	Rpm			
		Class				

## **APPENDIX**

**Appendix (A)**

**PRE-COMMISSIONING CHECKLIST FOR BOOSTER PUMP STATION**

PRE-COMMISSIONING CHECKLIST FOR BOOSTER PUMP STATION

Project Name .....	Pump Type .....
Work Contract No. .....	Pump Serial Nos. ....
Booster Stations .....	Pump .....
Name & Location .....	Pump .....
	Pump .....

**1. VALVES**

Function Checks	Direction	Open	Seats
a) Washdown/Priming Valves			
b) Suction Valves			
c) Discharge Valves			
d) Non-Return Valves			
e) Air Release Valves			

**2. PUMPS**

i) Manufacturers Pre-Start Up Checks (see attached sheets) completed	PUMP	PUMP	PUMP	PUMP

ii) Alignment Checks

See manual for procedure	No.	Parallel (mm)				Angular (mm)			
		PUMP	PUMP	PUMP	PUMP	PUMP	PUMP	PUMP	PUMP
Reading with pipework uncoupled	1								
	2								
	3								
	4								
Reading with pipework coupled	1								
	2								
	3								
	4								

Manufacturers tolerance:	Parallel ..... mm
	Angular ..... mm

PRE-COMMISSIONING CHECKLIST FOR BOOSTER PUMP STATION

3. ELECTRICAL					
i) Earthing Protection Check	S.B	PUMP	PUMP	PUMP	PUMP
a) Earth Resistance on Electrical Systems (<1 Ohm)					
b) Insulation Resistance Test Resistance Cables .....	See attached data sheet D (i) A				
c) Polarity check					
d) Earth Resistance Test for Lighting Protection System =	ohms				
(≤10 ohms)					
ii) Switchgear Protection	Setting		Checked by		
a) Over current protection					
b) Earth leakage setting					
iii) Pump Motor Insulation Resistance Test	Pump	Pump	Pump	Pump	
	R-Y				
	Y-B				
	B-R				
	L-N				
	L-E				
4. INSTRUMENTATION					
			Yes	No	
a) Installation/Assembly complete and in accordance with drawing					
b) Control cables insulation check (see attached sheet D(i))					
c) Isolation and Balancing Valves, bleed screws checked for operation over full strokes					
	Instrument				
	Instrument				
	Instrument				
	Instrument				

PRE-COMMISSIONING CHECKLIST FOR BOOSTER PUMP STATION

d) Instrument lines clear of obstruction, flushed through and checked for leaks

Instrument  
Instrument  
Instrument  
Instrument

Yes	No

e) Check Zero Calibration of Primary Loop Element:

With balancing valves on DP transmitter open, energise supply to instruments and measure loop current after 10 minutes

	Expected	Actual
Instrument	4,00 mA	mA
Instrument	4,00 mA	mA
Instrument	4,00 mA	mA
Instrument	4,00 mA	mA

If a value differs from that expected by more than 0.01 mA, reconfirm sensor range with D.P. range stamped on D all Tube/Orifice Plate, and then refer to manufacturers operating instructions for procedure to set zero and coarse span.

N.B. The fine span is pre-set at the factory and should not be adjusted unless there is reason to suspect an unexpected change in calibration. A precision pressure source is required before adjusting the fine span potentiometer.

PRE-COMMISSIONING CHECKLIST FOR BOOSTER PUMP STATION

f)	Check Integrator/Analogue Converter Calibration:				
<p>Confirm that the Meter Factor (written on the inside of the connection compartment) matches the settings of " switches S1, S2, S3 and S4 and link L1.</p> <p>(Details of the calibration necessary to determine the Meter Factor are contained in Appendix A of the Manufacturers' Instruction Manual).</p> <p>Refer to 'Analogue Converter Scaling' a page 10 of the Manufacturers' Instruction Manual for the procedure to check the calibration.</p>					
		Zero		Proportion or FS	
		Expected	Actual	Expected	Actual
Instrument		0,00 mA	mA	mA	mA
Instrument		0,00 mA	mA	mA	mA
Instrument		0,00 mA	mA	mA	mA
Instrument		0,00 mA	mA	mA	mA
<b>5. PUMP PROTECTION</b>					
a)	Low Level Probe in suction tank				m
b)	High Level Probe in suction tank				m
c)	High Level Probe in receiving reservoir				m
d)	Differential Pressure (D.P.) switch in discharge pipeline				m <sup>3</sup> /h
<b>6. MOTORS</b>					
a)	Check motor insulation resistance		Pump	Pump	Pump
		R-Y			
		Y-B			
		B-R			
		L-E			
b)	Motor winding resistance (Ohm)	U1-U2			
		V1-V2			
		W1-W2			

PRE-COMMISSIONING CHECKLIST FOR BOOSTER PUMP STATION

c)	Check motor direction (CW/CCW)		Yes	No
d)		PUMP		
		PUMP		
		PUMP		
		PUMP		
	Check thermister trip for motor over 37 kW (by shorting thermister)		Yes	No
		PUMP		
		PUMP		
		PUMP		

<b>7. OVERHEAD TRAVELLING CRANE</b>				
a) Tapes over breather holes removed			Yes	No
b) All damaged paintwork repaired				
c) Alignment check (N/A to monorail hoists)	Drawing Dimension	Measured Dimension	Permitted Tolerances	
	i) Crane span at each end of carriages		±6 mm	
	ii) Diagonal centres of crane wheels		±6 mm	
	iii) Crane span at crane rail level		±6 mm	
d) Safe work load _____tonnes painted on frame			Yes	

PRE-COMMISSIONING CHECKLIST FOR BOOSTER PUMP STATION

8. GENERATORS		
a) Manufacturers pre-start checks completed (see attached sheets)	Generator Unit	
b) Insulation Resistance Tests (MΩ) (see attached data sheet D(i) C)	Measured	Required
		>50 MΩ
i) Between load terminals and plant structure		>50 MΩ
ii) Between generator terminals and structure		>50 MΩ
iii) Between generator phases	R-Y	>50 MΩ
	Y-B	>50 MΩ
	B-R	>50 MΩ
		>1 MΩ
iv) Ancillary equipment: Heaters	Yes	No
c) Continuity tests: Phase and circuit connections checked		
d) Earthing protection check	Measured	Required
		< 1 ohm
i) Earth resistance on electrical system		
ii) Polarity verified	Yes	No
iii) Generator neutral earthing	Yes	No
e) Battery Checks	Measured	
	i) Standing voltage measured	Volts
	ii) Starting voltage measured	Volts
	iii) Specific gravity	
	iv) Level of electrolyte	
	v) Trickle charger checked for correct operation	Amps

PRE-COMMISSIONING CHECKLIST FOR BOOSTER PUMP STATION

f) Fuel system	Yes	No
i) Fuel tank level sensors checked for correct operation of pump and alarms		
ii) Fuel lines purged of air		
g) Before starting	Yes	No
i) All lubrication systems checked as correct		
ii) Ambient temperature of area		
iii) Cooling water gauge reading		
h) Fire/safety	Yes	No
i) Fire extinguishers installed and fully charged		
ii) Fire fuel shut-off valve checked (remove fusible link)		
<b>9. SURGE SUPPRESSION EQUIPMENT</b>		
a) Compressors: Manufacturers pre-start up checks complete (see attached sheets)	Compressor A	Compressor B
b) Pipeline length	m	m
c) Double orifice vented NRV's: No.		
d) Double orifice inflow check NRV's: No.		
e) Vessel size	m <sup>3</sup>	m <sup>3</sup>
f) Outlet size	mm	mm
g) Outlet NRV	Yes/No	Yes/No
h) Normal operating pressure	kPA	kPA
i) PRV setting	kPA	kPA
j) Maximum surge pressure	kPA	kPA
k) Minimum Surge pressure	kPA	kPA

PRE-COMMISSIONING CHECKLIST FOR BOOSTER PUMP STATION

l) Alarm setting high/low  m) Compressor settings start/stop n) JKPP type approval o) JKPP installation approval	High		Low	
	Rated	Actual	Rated	Actual
	mm	mm	mm	mm
	Stop		Start	
	Rated	Actual	Rated	Actual
	mm	mm	mm	mm
	Yes/No			
	Yes/No/NA			
Above checks satisfactorily completed.				
Remarks:				
	Checked By Contractor	Supervised by Consultant	Witnessed by JBALB Representative	
Name				
Signature				
Designation				
Date				

PRE-COMMISSIONING CHECKLIST FOR BOOSTER PUMP STATION

<b>CABLE CHECK SHEET</b>							
Project Name: .....				Capacity: .....			m <sup>3</sup> /hr
Work Contract No.: .....				Operation: .....			hr/d
Site Location: .....				Power/Control Cables			
Cable Tagging	Cable Name	From	To	Type of Cable	No. of Cable	Rated Voltage (V)	Insulation Resistance Test (MΩ)
The above checks have been completed satisfactorily.						Yes	No
Remarks:							
	Checked By Contractor		Certified by Consultant			Witnessed by JBALB Representative	
Name							
Signature							
Designation							
Date							



**JABATAN BEKALAN AIR LUAR BANDAR (JBALB) SARAWAK**

**TESTING AND COMMISSIONING DOCUMENT**

**FOR**

**WATER TREATMENT PLANT**

..... **DIVISION**

**CONTRACT NO: .....**

## **TABLE OF CONTENTS**

<b><u>No.</u></b>	<b><u>Description</u></b>	<b><u>Pages</u></b>
1	Pre-Requirement for Document Submission Prior To Testing and Commissioning Activity	1
2	Process flow for Commissioning of Water Treatment Plant	2-7
3	Method Statement - Water Treatment Plant Pre & Post Commissioning	8-10
4	Guidelines and Checklist for Full Testing & Commissioning of Water Treatment Plants	11
5	General Notes for Pre-commissioning, Commissioning and Acceptance Test for Water Treatment Plants	12-18
6	Commissioning Checklist For Water Treatment Plant	19-43
7	Acceptance Tests for Treatment Works	44-47
8	Table A : Pump Monitoring Table	49
9	Table B : Pump Test Certificate	50
10	List of Equipment	51-57
11	Appendix (A) Pre-Commissioning Checklist for Water Treatment Plants	58-90
12	Appendix (A) - Cable Check Sheet	91

	<b>TESTING AND COMMISSIONING DOCUMENT FOR WATER TREATMENT PLANT</b>	Contract No:
		Rev: 1
		Date:

**PRE-REQUIREMENT FOR DOCUMENT SUBMISSION PRIOR TO  
TESTING & COMMISSIONING ACTIVITY**

No	Item	YES	NO	N/A	REMARKS
1	Method Statement Of T&C				
2	Operation & Manual (O&M)				
3	Factory Acceptance Test Report (FAT)				
4	Site Acceptance Test Report (SAT)				
5	Testing and commissioning checklist				
6	QAQC check records documentation review before Testing and Commissioning (T&C) but not limited to: <ul style="list-style-type: none"> <li>I. Equipment data sheet</li> <li>II. Equipment manufacture test certificate</li> <li>III. Instrument calibration certificate</li> <li>IV. As build Drawing <ul style="list-style-type: none"> <li>➤ Mechanical &amp; Electrical</li> <li>➤ Civil &amp; Structure</li> </ul> </li> </ul>				
7	Site walk/Inspection prior to readiness of T&C				
9	Training on equipment in regards to safety, operating, maintenance and emergency practice/ procedure				
10	Punch list closed – if any				
11	Non Conformance Report (NCR) closed – if any				

Above requirement shall be submitted **2 weeks** before T&C except FAT report:

	<b>TESTING AND COMMISSIONING DOCUMENT FOR WATER TREATMENT PLANT</b>	Contract No:
		Rev: 1
		Date:

**PROCESS FLOW FOR COMMISSIONING OF  
WATER TREATMENT PLANT**

	<b>TESTING AND COMMISSIONING DOCUMENT FOR WATER TREATMENT PLANT</b>	Contract No:
		Rev: 1
		Date:

**COMMISSIONING OF NEW JBALB WATER TREATMENT PLANTS**

**1.0 Commissioning Team**

The commissioning of all new JBALB water treatment plants shall be carried out by designated officers coordinated Jabatan Bekalan Air Luar Bandar (JBALB) Headquarters. The commissioning team shall consist of the following: -

**1.1 JBALB Headquarters**

- a) Mechanical Engineer
- b) Electrical Engineer
- c) Civil Engineer (Related Project)
- d) Chemist
- e) Assistant Engineer

**1.2 JBALB Divisional**

- a) Divisional Water Engineer (DWE)/Officer Incharge of Division(OIC)
- b) Assistant Engineer, J29

**1.3 JBALB Project Management Team**

- a) Divisional Water Engineer (DWE)/Officer Incharge of Division(OIC)
- b) Assistant Engineer, J29

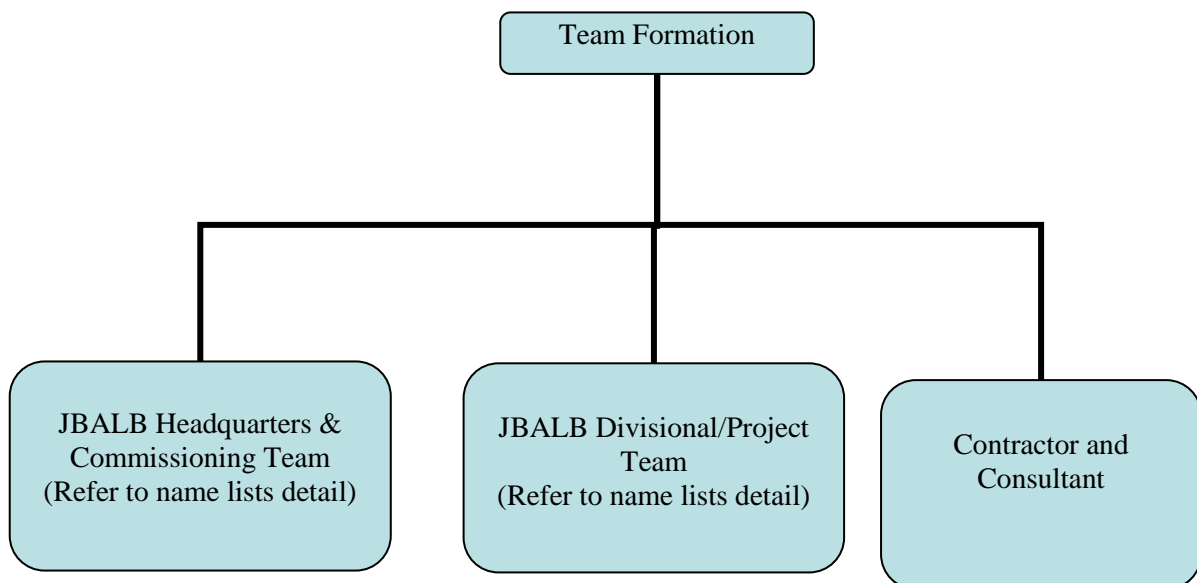



**TESTING AND COMMISSIONING  
DOCUMENT FOR WATER  
TREATMENT PLANT**

Contract No:

Rev: 1

Date:

**2.0 Methodology**

- 2.1 The Mechanical Engineer from JBALB Headquarters will head the commissioning team and the Divisional Water Engineer (DWE), Assistant Engineer and Assistant Technician/Technician are allocated the following tasks to assist in the commissioning.
- 2.2 Pembantu Kemahiran H17 & Pembantu Awam H11/14 will assist the commissioning teams and will take over the plant operation after successful commissioning and handing over. In this respect, they will get hands-on experience in the plant operation.
- 2.3 Project Management Team from JBALB Divisional/Regional Office's role is to be the coordinator to instruct consultant/contractor to execute and implement the commissioning process as per guidelines and checklist. They are responsible to coordinate with JBALB Headquarters Commissioning Team to ensure that proper guidelines and procedure is implemented prior to the commissioning of Booster Pump Station are in accordance with the guidelines before handing over to JBALB Division.

**PRE-COMM/COMMISSIONING  
PROCESS (Water Treatment Plant)**

**PRE-COMMISSIONING PROCESS**

What to check?

Physical and visual check of control equipment i.e. Pumps, Valves, PLC's, Generator set, MSB, etc. as per Guidelines of Pre-Commissioning Checklists & Contract Document.

**COMMISSIONING PROCESS**

What to check?

Individual System Checks as per Guidelines of Commissioning Checklists and Data Sheets.

*Commissioning  
successful*

**DOCUMENTATION / HANDOVER**

Parties involved: Divisional Office and JBALB Headquarters

**REFRESHER/ TRAINING**

- As per contract (external)
- To be conducted by JBALB Divisional and JBALB HQ (recommended once every six (6) month)

	<b>TESTING AND COMMISSIONING DOCUMENT FOR WATER TREATMENT PLANT</b>	Contract No:
		Rev: 1
		Date:

### **3.0 Tasks and Duties**

- i) The commissioning team will witness the testing of all items of equipment, pipework, fittings and appurtenant (accessories) works to ensure that they are correctly installed and capable of proper operation.
- ii) The team will witness start up and running each item of equipment separately until they are satisfied that it is capable of proper operation.
- iii) After each item of equipment has been tested separately, the various items will be run concurrently to commission the plant.

#### **3.1 In carrying out (i) to (iii) above, the team shall ensure that:-**

- i) The correct sequence of operation of the plant is checked and documented.
- ii) Plant control systems are checked.
- iii) Calibration on Testing and Measuring tools is carried out.
- iv) Switchboards, control panels, alarm systems, overloads, and safety equipment are tested.
- v) The alignment, mounting and configuration of pumps and drives, including the direction of rotation are checked.
- vi) The various lubrication systems and greasing systems are checked, including pump shaft lubrication and stuffing box seal requirements.
- vii) The pipework valves and gauges are correctly installed and operate satisfactorily. The appropriate valve positions shall be determined for the different modes of operation of the plant and documented.
- viii) The chemical mixing, feeding and dosing equipment shall be tested and calibrated.
- ix) Load tests are carried out on lifting equipment.
- x) The necessary chemical testing equipment is provided and in working order.
- xi) All other tools and equipment necessary have been provided and are in working order.

	<b>TESTING AND COMMISSIONING DOCUMENT FOR WATER TREATMENT PLANT</b>	Contract No:
		Rev: 1
		Date:

### 3.2 During the commissioning of the plant, the team shall ensure that: -

- i) The limits of hydraulic operation of the various units of the plant are determined.
- ii) The appropriate flow rate through the plant is determined to minimize “on-off” operation. Guides on pumping rates for the raw water and treated water pumps shall be established.
- iii) The clarifiers are operated with the appropriate level of coagulant to achieve a well developed floc blanket.
- iv) The rate of de-sludging of the clarifiers is determined.
- v) The filters are operated sufficiently long to establish head loss characteristics and backwash requirements.
- vi) The filter backwash system and air scour are operated correctly. The correct procedure for backwashing of the filters is determined and documented.
- vii) As far as possible, the appropriate levels of dosing of chemicals for the plant are determined. In particular, the appropriate level of post dosing for pH correction is determined.

### 3.3 Documents and operation manuals

The following documents shall form part of the commissioning:

- i) Procedures on water treatment process;
- ii) Buku Panduan Kerja Pertukangan Atenden Loji Bekalan Air;
- iii) Buku Panduan Kerja Pertukangan Atenden Pam Bekalan Air;
- iv) Buku Panduan Kerja Pertukangan Atenden Enjin Bekalan Air;
- v) Perintah-Perintah Tetap Pihak Berkuasa Bekalan Air JKR;
- vi) Other operation manuals for the s and equipment.

### 3.4 Refresher/Induction Training

During the commissioning of the plant, the Divisional Water Engineer (DWE), Assistant Engineer, Assistant Technician/Technician and attendants allocated to assist the teams, will undergo “hands on” training in preparation for accepting responsibility for operation of the plant. This training role will be a significant aspect of the duties of the commissioning team.

	<p style="text-align: center;"><b>TESTING AND COMMISSIONING DOCUMENT FOR WATER TREATMENT PLANT</b></p>	Contract No:
		Rev: 1
		Date:

### 3.5 Handing Over and Documentation

3.5.1 When the plant is operating satisfactorily and treated water has been supplied into the existing reticulation system, it will be handed over to the JBALB Divisional staff.

3.5.2 The commissioning team will prepare four (4) copies of the commissioning report, (1) one copy to the Regional Manager, (1) one copy to the Divisional Water Engineer and (2) two copies to JBALB Headquarters.

3.5.3 The report shall contain as a separate section, the recommended procedure for operating the various items of the plant including the following:

- i) Valve on-off schedules,
- ii) Switchboard operation and use of control panels and monitors.
- iii) Observed rate of desludging of clarifiers and backwashing of filters
- iv) Operation of the raw water pumps and clear well pumps to integrate the plant into the existing system and optimize its operation.

3.5.4 An assessment of the induction training of operator staff shall be given.



**TESTING AND COMMISSIONING  
DOCUMENT FOR WATER  
TREATMENT PLANT**

Contract No:

Rev: 1

Date:

**METHOD STATEMENT  
WATER TREATMENT PLANT PRE & POST COMMISSIONING**

	<b>TESTING AND COMMISSIONING DOCUMENT FOR WATER TREATMENT PLANT</b>	Contract No:
		Rev: 1
		Date:

**METHOD STATEMENT**  
Water Treatment Plant Pre & Post Commissioning

Background Information

Project Name	
Contract No.	

Pre & Post Commissioning Implementation

Divisional Involvement	<ol style="list-style-type: none"> <li>1. Divisional Office representative shall be present during pre-commissioning and commissioning stage to witness and comment any dissatisfaction /query through Project Management Team / Commissioning Team representative.</li> <li>2. Divisional Office representative shall be at least Assistant Engineer, J29 of Mechanical or Electrical to be involved during pre-commissioning and commissioning stage (especially M&amp;E equipment testing).</li> <li>3. Water treatment plant operator (PRAK) shall be involved during system operational testing for the purpose of familiarization of new treatment plant. Certificate of Practical Completion (CPC) shall be to the satisfaction of JBALB Commissioning Team and JBALB Divisional Office SO/SOR/OIC. This is to ensure proper handing over and operational needs are met and achieved as per design in the Contract.</li> </ol>
New Pipe interconnection to existing piping system	<ol style="list-style-type: none"> <li>1. JBALB Project Management Team concerned shall notify any pipe interconnection and submit method statement for interconnection work to JBALB Divisional Office prior to the commencement of actual work.</li> <li>2. Method statement must be agreed between Project Management Team and Respective JBALB Divisional Office before any work can proceed.</li> <li>3. Upon agreement on the interconnection Method Statement, the affected Divisional Office (DWE/OIC) shall issue notice of water supply interruption to the public prior to the execution of interconnection work either via Corporate Communication or Information Department (which ever) is more efficient and cost effective within a weeks notice.</li> <li>4. Any actual shutdown to the existing system shall be done by JBALB Project Management Team or representative from JBALB Divisional Office assisted by the Contractor involved.</li> <li>5. The interconnection work and any reinstatement work which is affected by the interconnection process shall be done by the contractor involved to the satisfaction of representative of both PMT and Divisional Office.</li> </ol>



**TESTING AND COMMISSIONING  
DOCUMENT FOR WATER  
TREATMENT PLANT**

Contract No:

Rev: 1

Date:

<p>Consumables Requirement</p>	<ol style="list-style-type: none"> <li>1. After every successful Testing and Commissioning, it is crucial that the Appointed Contractor/Consultant prepare and advice on the usage and quantity of consumable required like chlorine, aluminum sulphate, polymer and soda ash shall be made available as stock for at least 3 to 6 months (subject to availability &amp; plant locality) for operational use after project completion (CPC).</li> <li>2. It is recommended that the information on where and how to acquire these required consumable shall be made known to the JBALB Divisional Office for reference of their planning and procurement process by the users.</li> <li>3. Material acquisition inclusive of M&amp;E parts shall be identified and JBALB Divisional Office is recommended to acquire major parts for major pumps and dosing pump for stock in advance for the ease of maintenance after the end of Defect Liability Period (DLP).</li> </ol>
<p>Recommendation on Operational and/Or Overall Maintenance Plan</p>	<ol style="list-style-type: none"> <li>1. Operation and maintenance manual for the water treatment plant shall be provided by the contractor to the JBALB Divisional Office and JBALB Headquarters for references on operational matters.</li> <li>2. JBALB Divisional Office shall produce the Maintenance Plan which include periodic and preventive/predictive maintenance of all major equipment i.e. Treated water pump, submersible water intake pump and control panels. It is recommended that all major equipment is checked and inspected at a regular interval of three (3) months (minimum) by Audit or representatives from JBALB Headquarters.</li> <li>3. Divisional Office shall coordinate with JBALB Headquarters regarding procedure, schedule and costing for maintenance of all equipment. It is advisable that this coordination is initiated prior to the end of project's DLP.</li> </ol>
<p>Recommendation on manpower requirement of new Water Treatment Plant (WTP)</p>	<ol style="list-style-type: none"> <li>1. It is recommended that DWE/OIC's to review their current operation setup and manpower requirement to suit the new WTP prior to the completion of the project. It would be best that proper proposal on operation of new WTP to be worked out at the commissioning stage since forecast on actual manpower required can be identified clearly with the involvement of Divisional Office at this stage.</li> </ol>

	<p>TESTING AND COMMISSIONING DOCUMENT FOR WATER TREATMENT PLANT</p>	Contract No:
		Rev: 1
		Date:

**GUIDELINES AND CHECKLIST FOR FULL  
TESTING & COMMISSIONING OF WATER TREATMENT PLANT**

	<p>TESTING AND COMMISSIONING DOCUMENT FOR WATER TREATMENT PLANT</p>	Contract No:
		Rev: 1
		Date:

**General Notes for Pre-commissioning,  
Commissioning and Acceptance Tests  
Water Treatment Plant**

	<b>TESTING AND COMMISSIONING DOCUMENT FOR WATER TREATMENT PLANT</b>	Contract No:
		Rev: 1
		Date:

**GENERAL NOTES FOR  
COMMISSIONING AND ACCEPTANCE TESTING  
OF WATER TREATMENT PLANT**

The following notes are intended as a guide to the completion Pre-Commissioning and Commissioning Works in a manner which will be consistent throughout all new Treatment Plants.

**Guidelines and Checklists for Pre-commissioning (Appendix A)**

These are checks which are required to be undertaken by the Mechanical/Electrical Sub-Contractor and are supervised by Contractor's staff. They are intended as a virtual 'check list' to ensure that all items of equipment have been installed correctly and have been prepared for commissioning/operation.

**Guidelines and Checklists for Commissioning**

These are checks which are required to be undertaken by Contractor's staff in the presence of Jabatan Bekalan Air Luar Bandar (JBALB) staff.

It is essential that JBALB staffs are present in order to witness measurements, readings, and observations made during these checks. For this reason, sufficient notice should be given by Contractor to JBALB. **The contractual requirement is for 21 days' notice.** It is possible however, to advise later changes to programme by facsimile/telephone when absolutely necessary.

Guidelines and Checklists for Commissioning are intended to be applicable to ALL Treatment Plants. It is unavoidable, therefore, that certain sections will not be applicable to a particular scheme. Inapplicable sections will normally have been crossed out or struck through before the time of commissioning. If this is not the case, then a comment should be made by the signatories indicating which sections have not been undertaken or witnessed.

It is absolutely essential that Mechanically/Electrically competent personnel are delegated to witness the commissioning of Mechanical and Electrical equipment in order to avoid protracted discussions and arguments on methods/techniques employed to generate the data.

	<b>TESTING AND COMMISSIONING DOCUMENT FOR WATER TREATMENT PLANT</b>	Contract No:
		Rev: 1
		Date:

### Specific Guidance: Pre-Commissioning / Commissioning

#### 1. Intake/Raw Water Pump

Pump Test Sheet - when recording pump performance data, it is useful if a sample check on flow rate can be performance in order to verify the flowmeter accuracy.

Readings are taken over the operating range of the pumps. Data are calculated and graphs drawn SUBSEQUENT to the commissioning. JBALB should witness the result taken; results will be presented to JBALB personnel at a later date.

#### 2. Aerators

It is only important to test the performance of the aerators when:

- a) There is pollution and the dissolved oxygen in the river is low, or
- b) The water is coming from a borehole and dissolved carbon dioxide is high.

#### 3. Flocculators

The operation of the torque switch is only checked electrically.

#### 4. Backwash Pumps

Table A: The correct operation of pumps can only be assessed by Mechanically competent and experienced personnel. Manufacturers' literature states that bearing temperature should be checked by hand: if a normal person can hold a bearing cover without feeling pain, then it is highly probable that the temperature is below 60 degree C and that the bearing is running normally. However, if available, an electronic surface temperature meter should be used to verify the actual temperature.

If the bearing is running hot, this does not necessarily mean that it is defective; in nine cases out of ten, it is usually found that it has been over packed with grease, and that cleaning and re-packing cures the problem.

'Abnormal' noise and vibration is a very subjective assessment and again should be left to experienced personnel.

Table B: Readings are taken over the operating range of the pumps. Data are calculated and graphs drawn subsequent to the commissioning of the Treatment Plant. JBALB personnel should witness the readings taken, results will be presented to JBALB Divisional at a later date.

	<b>TESTING AND COMMISSIONING DOCUMENT FOR WATER TREATMENT PLANT</b>	Contract No:
		Rev: 1
		Date:

## 5. *Treated Water Pumps*

Similar comments as for Backwash Pumps apply regarding Table A and B.

### a) *Check high Reservoir level shut off control*

If the reservoir is greater than 1 km from the Treatment Plant, pumps are stopped by a differential pressure switch which is operated on a decrease in flow. It may not be convenient to wait for what could amount to several hours in order to demonstrate the correct operation of this cut-out. All that is necessary in this case is to slowly close the pump discharge valve and note the flow at which the pump trips.

For reservoirs less than 1 km from the Treatment Plant, pumps are stopped by level electrodes which respond to the conduction of an electric current between them (when both are immersed in water). Again, correct operation can be demonstrated by lowering the High Level electrode into the water, or by shorting the Reference and High Electrodes momentarily.

### b) *Check Pumps restart automatically*

If a low flow trip, then re-start is by an adjustable timer. All that is necessary in this case to demonstrate correct operation, without having to wait for an excessive time, is to temporarily adjust the timer to a value of a few minutes.

Where trip is by electrode, re-start is also by electrodes, in this case by a break in the flow of electric current between them. (When the water level falls below the Low Level Electrode) Correct operation can be demonstrated in this case by raising the Low Level Electrode clear of the water surface, or by momentarily disconnecting the connection to the Low Level Electrode.

### c) *Check Pumps stop when Balance tank is at low level; Check pumps re-start automatically*

In the case of a balance tank, trip and re-set are both by electrode and the same comments made above apply here.

## 6. *Air Blowers*

The un-loader valves should be permanently shut for normal operation, after initial checks are complete.

The operation of the relief valves is checked by running the blower with the discharge valve closed and the un-loader valve open: The un-loader valve is then slowly closed until the relief valve lifts. The pressure can then be read from the discharge pressure gauge.

	<b>TESTING AND COMMISSIONING DOCUMENT FOR WATER TREATMENT PLANT</b>	Contract No:
		Rev: 1
		Date:

#### 7. *Sludge Tank/Pumps*

After shut off at low level, the pumps require manual re-setting to re-start.

#### 8. *Alum Dosing System*

Assume top water level to be at the invert level of the overflow outlet. This ensures that the operator consistently makes up a correct known volume of dosing solution.

Dosing solutions should always be 5% alumina content, as the flow-meter is calibrated for the appropriate specific gravity. If the required dose rate is outside the flow-meters range and a different dosing solution strength is necessary, then a check of actual flow rate should be made to determine the correction factor.

#### 9. *Soda Ash Dosing System*

To check the powder feed rate at different potentiometer settings; waits for a vibration period to start and collect powder for 1 to 2 minutes (depending on setting). The powder collected is then weighed and the kg/hr rate computed.

#### 10. *Travelling Crane*

The JKKP Certificate for the crane should be issued and available for record.

#### 11. *Surge Suppression Equipment*

After the surge suppression equipment is commissioned, all that is required under this section is to observe the maximum and minimum pressures indicated on the surge arrestor pressure gauge on starting and stopping the pump from a position of pressure equilibrium. The JKKP Certificate for the Surge Suppression Equipment should be issued and available for record.

#### 12. *Generating Sets*

Department of Environment (DOE) Approval Certificate for installation of Generating Set should be issued and available for record.

#### 13. *Fire Protection System*

Bomba Approval on all Fire Protection System should be issued and available for record.

#### 14. *Fuel Storage System*

Department of Environment (DOE) Approval Certificate for installation of Fuel Storage System should be issued and available for record.

	<b>TESTING AND COMMISSIONING DOCUMENT FOR WATER TREATMENT PLANT</b>	Contract No:
		Rev: 1
		Date:

### Specific Guidance: Acceptance Tests

#### 1. *Water Quality Record*

The JBALB operators will normally carry out the following tests:

- pH
- Turbidity
- Colour
- Chlorine (free or total)
- Aluminium
- Fluoride

#### 2. *Flow and Dosing Record*

This data will normally be recorded by JBALB operators but Contractor's staff may assist if necessary.

#### 3. *Machinery Operating Records (currents and pressures)*

As per the flow and dosing records.

#### 4. *Calculation of the Saturation pH*

These calculations and tests will be carried out by Contractor's commissioning staff. In the event of the target pH being higher than maximum Malaysia Water Supply Quality Standard drinking water pH, a suitable target pH will be decided in consultation with JBALB. In any event, if daily monitoring indicates no significant change in the saturation pH, the frequency of testing maybe decreased.

	<b>TESTING AND COMMISSIONING DOCUMENT FOR WATER TREATMENT PLANT</b>	Contract No:
		Rev: 1
		Date:

### **General Acceptance Tests Guidance**

The commissioning team will instruct the operators and Contractor's staff on the use of appropriate test equipment.

Additionally, full instruction will be given on determination of chemical dose rates and operational procedures to achieve them.

The Acceptance Test will normally be the responsibility of contractor's staff, but commissioning staff will be available for process advice when necessary.

Collection of water samples and subsequent delivery to an independent laboratory will be the responsibility of Contractor's staff.

It should be noted that samples for bacteriological analysis should be tested as soon as possible after collection. Samples for chemical analysis are not so critical.

It is required of JBALB representatives that they acknowledge the period of operation defined as the acceptance test.

Quality based on the results must be to National Water Quality Standard for Malaysia (NWQS). What are specified must meet the NWQS standard to achieve KPI.

N.B. JBALB representatives are not being asked to 'accept' or take over schemes. All that is required of them is to witness the proceedings and if necessary, to draw up a 'snag list' of items considered incomplete or defective. This snag list, together with any comments considered appropriate, should be referred to JBALB Regional Office/JBALB Divisional who is the agency responsible for accepting schemes.

	<p><b>TESTING AND COMMISSIONING PLAN FOR WATER TREATMENT PLANT</b></p>	Contract No:
		Rev: 1
		Date:

**COMMISSIONING CHECKLISTS FOR WATER TREATMENT PLANT**

**COMMISSIONING CHECKLISTS FOR WATER TREATMENT PLANT**



**TESTING AND COMMISSIONING  
PLAN FOR WATER TREATMENT  
PLANT**

Contract No:

Rev: 1

Date:

**COMMISSIONING CHECKLISTS FOR WATER TREATMENT PLANT**

Project Name :	Capacity : m <sup>3</sup> /hr
Work Contract No. :	Operation : hr/d

**INTAKE/RAW WATER PUMP**

1. Run each pump for approximately 1 hour to check current consumption.

Unit	Rated Full Load Current (FLC) (A)	Measured FLC (A)			Measured FLC (A)		
		R	Y	B	R	Y	B
PUMP 1							
PUMP 2							
PUMP 3							
PUMP 4							

2. Close inlet penstocks/valves and run pumps to check operation of low level shut-off

Water level at shut-off

Meter

3. Check drawdown in sump; inside/outside level difference

Meter

4. Run pumps until steady state conditions achieved; note discharge pressure and flow rate (see attached data sheet A). *Note: To simulate output at 0%, 25%, 50%, 75% & 100% via manual valve control or via Variable Speed Drive (VSD) control.*

Plot data on manufacturers test certificate performance satisfactory

Yes

No

Commissioning complete, system ready for use.

**Yes**

**No**

Remarks:

	Checked by Contractor	Certified by Consultant	Witnessed by JBALB Representative
Name			
Signature			
Designation			
Date			



**TESTING AND COMMISSIONING  
PLAN FOR WATER TREATMENT  
PLANT**

Contract No:

Rev: 1

Date:

**COMMISSIONING CHECKLISTS FOR WATER TREATMENT PLANT**

Project Name :	Capacity :	m3/hr
Work Contract No. :	Operation :	hr/d

**AERATOR**

1. With system in operation, check weir levels under dynamic conditions.

Unit No.	Top	Mid	Lower
North			
East			
South			
West			

Within tolerance  $\pm 3\text{mm}$

	Yes	No
Commissioning complete, system ready for use.	<b>Yes</b>	<b>No</b>

Remarks:

	Checked by Contractor	Certified by Consultant	Witnessed by JBALB Representative
Name			
Signature			
Designation			
Date			



**TESTING AND COMMISSIONING  
PLAN FOR WATER TREATMENT  
PLANT**

Contract No:

Rev: 1

Date:

**COMMISSIONING CHECKLISTS FOR WATER TREATMENT PLANT**

Project Name :	Capacity :	m <sup>3</sup> /hr
Work Contract No. :	Operation :	hr/d

**FLOCCULATORS**

1. With units in operation, check weir levels.

	Unit No.1 (Meter)	Unit No.2 (Meter)	Unit No.3 (Meter)
North			
East			
South			
West			

Within tolerance  $\pm 3$ mm

Yes	No

2. Run Flocculator/scrapper gearboxes for 1 Hours to check current consumption.

Unit No.1	Flocc G/bx A			Floc G/bx B			S per G/bx		
Rated FLC (A)									
Measured FLC (A)	R	Y	B	R	Y	B	R	Y	B
Design S speed (RPM)									
Actual S speed (RPM)									
Unit No.2	Flocc G/bx A			Flocc G/bx B			Scrapper G/bx		
Rated FLC (A)									
Measured FLC (A)	R	Y	B	R	Y	B	R	Y	B
Design S speed (RPM)									
Actual S speed (RPM)									
Unit No.3	Flocc G/bx A			Flocc G/bx B			Scrapper G/bx		
Rated FLC (A)									
Measured FLC (A)	R	Y	B	R	Y	B	R	Y	B
Design S speed RPM)									
Actual S speed (RPM)									

Check for uncharacteristic noise or vibration whilst gearboxes are in operation.



**TESTING AND COMMISSIONING  
PLAN FOR WATER TREATMENT  
PLANT**

Contract No:

Rev: 1

Date:

**COMMISSIONING CHECKLISTS FOR WATER TREATMENT PLANT**

Project Name :	Capacity :	m <sup>3</sup> /hr
Work Contract No. :	Operation :	hr/d

3. Check operation of torque switch;  
Satisfactory

Yes	No

4. Unit performance check

	Turbidity (water in)	Turbidity (water out)
Unit No.		
Unit No.		
Unit No.		

Commissioning complete, system ready for use.

<b>Yes</b>	<b>No</b>

Remarks:

	Checked by Contractor	Certified by Consultant	Witnessed by JBALB Representative
Name			
Signature			
Designation			
Date			



**TESTING AND COMMISSIONING  
PLAN FOR WATER TREATMENT  
PLANT**

Contract No:

Rev: 1

Date:

**COMMISSIONING CHECKLISTS FOR WATER TREATMENT PLANT**

Project Name :	Capacity :	m <sup>3</sup> /hr
Work Contract No. :	Operation :	hr/d

**FLOCCULATOR/CLARIFIERS/SEDIMENTATION TANK**

1. With unit in operation, check weir levels.

Percentage length of weir (%)	Unit No.	Unit No.	Unit No.
0			
33			
67			
100			

Within tolerance  $\pm 3$ mm

2. Check drainage line adequacy during conditions of unit draindown and overflow. Satisfactory

Yes	No

3. Performance check: Turbidity

	Turbidity (water in)	Turbidity (water out)
Unit No.		
Unit No.		
Unit No.		
Yes	No	

Commissioning complete, system ready for use

Remarks:

	Checked by Contractor	Certified by Consultant	Witnessed by JBALB Representative
Name			
Signature			
Designation			
Date			



**TESTING AND COMMISSIONING  
PLAN FOR WATER TREATMENT  
PLANT**

Contract No:

Rev: 1

Date:

**COMMISSIONING CHECKLISTS FOR WATER TREATMENT PLANT**

Project Name :	Capacity : m <sup>3</sup> /hr
Work Contract No. :	Operation : hr/d

**RAPID GRAVITY FILTERS**

1. Check filters performances at normal and maximum rated flows.

Plant throughput .....m <sup>3</sup> /hour (as measured by plant inlet flow meter)				
Head over cleaned media	Filter No.	Filter No.	Filter No.	Filter No.
Normal rated flow .....m <sup>3</sup> /hour				
Max flow (1 unit back-washing) .....m <sup>3</sup> /hour				
Backwash (w/o air) head over weir				
Backwash (with air) head over weir				

2. Drain down filters to backwash weir level and check even air distribution; satisfactory
3. Backwash flow rate (w/o air) set at
4. Backwash flow rate (with air) set at
5. Air scour pressure from blower
6. Design air flow rate
7. Check media surfaces level after backwashing
8. Check drainage line adequacy during conditions of drain down and backwash – Satisfactory
9. Unit drain down time from full

Yes	No
	m <sup>3</sup> /hour
	m <sup>3</sup> /hour
	bar
	m <sup>3</sup> /min
Yes	No



**TESTING AND COMMISSIONING  
PLAN FOR WATER TREATMENT  
PLANT**

Contract No:

Rev: 1

Date:

**COMMISSIONING CHECKLISTS FOR WATER TREATMENT PLANT**

10. System performance check

	Turbidity (water in)	Turbidity (water out)
Filter No.		
Filter No.		
Filter No.		
Filter No.		

Commissioning complete systems ready for use.

**Yes**

**No**

	Checked by Contractor	Certified by Consultant	Witnessed by JBALB Representative
Name			
Signature			
Designation			
Date			



**TESTING AND COMMISSIONING  
PLAN FOR WATER TREATMENT  
PLANT**

Contract No:
Rev: 1
Date:

**COMMISSIONING CHECKLISTS FOR WATER TREATMENT PLANT**

Project Name :	Capacity : m3/hr
Work Contract No. :	Operation : hr/d

**BACKWASH PUMPS**

1. Run each pump for 10mins to check current consumption.

Unit	Rated Full Load Current (FLC) (A)	Measured Full Load Current (FLC) (A)		
		R	B	Y
Pump				
Pump				
Pump				

2. Run each pump for 2 hours or until bearing/gland temperature is stabilized; check temperature. Check motor and pump for noise, vibration, adjust gland leakage.

Satisfactory Pump  
Pump  
Pump

Yes	No

3. Check pump controls:

Balance tank low level shut off  
Backwash tank high level shut off

4. Run pumps; take readings of discharge pressure and flow rate (see data sheets ..... attached). *Note: To simulate output at 0%, 25%, 50%, 75% & 100% via manual valve control. or via Variable Speed Drive (VSD) control.*

Plot points on manufacturers test curve  
Performance satisfactory Pump  
Pump  
Pump

Yes	No



**TESTING AND COMMISSIONING  
PLAN FOR WATER TREATMENT  
PLANT**

Contract No:

Rev: 1

Date:

**COMMISSIONING CHECKLISTS FOR WATER TREATMENT PLANT**

5. Checks pumps speeds at maximum flow (valves fully open)

Unit	Rated speed (RPM)	Measured speed (RPM)
Pump		
Pump		
Pump		

Commissioning complete systems ready for use.

**Yes**

**No**

Remarks:

	Checked by Contractor	Certified by Consultant	Witnessed by JBALB Representative
Name			
Signature			
Designation			
Date			



**TESTING AND COMMISSIONING  
PLAN FOR WATER TREATMENT  
PLANT**

Contract No:

Rev: 1

Date:

**COMMISSIONING CHECKLISTS FOR WATER TREATMENT PLANT**

Project Name :	Capacity :	m3/hr
Work Contract No. :	Operation :	hr/d

**TREATED WATER PUMPS**

1. Manufacturers pre-start checks complete

Yes	No

2. Run each pump for approx. 60 minutes, to check current consumption.

Unit	Rated Full Load Current (FLC),(A)	Measured Full Load Current (FLC), (A)		
		R	Y	B
Pump				
Pump				
Pump				
Pump				
Pump				
Pump				

3. Run each pump for 2 hours or until Bearing/Gland temperature is constant. Check motor and pump for uncharacteristic noises or vibration. Adjust gland leakage.

Satisfactory

Unit	Yes	No
Pump		
Pump		
Pump		
Pump		
Pump		
Pump		



**TESTING AND COMMISSIONING  
PLAN FOR WATER TREATMENT  
PLANT**

Contract No:
Rev: 1
Date:

**COMMISSIONING CHECKLISTS FOR WATER TREATMENT PLANT**

5. Check pump controls	Unit	Low Level (Balance Tank)	High Level (Treated W.T)			
	Pump					
	Pump					
	Pump					
	Pump					
	Pump					
	Pump					
Pumps restart automatically after		Time	Level			
6. Run pumps; take readings of discharge pressure and flow rate (see data sheet .....)  <i>Note: To simulate output at 0%, 25%, 50%, 75% &amp; 100% via manual valve control. or via Variable Speed Drive (VSD) control.</i>	Unit	Yes	No			
	Pump					
	Pump					
	Pump					
	Pump					
	Pump					
	Pump					
Performance satisfactory						
7. Check pump/motor speeds						
Unit	Pump	Pump	Pump	Pump	Pump	Pump
Rated speed (RPM)						
Measured speed (RPM)						
Commissioning complete; system ready for use				Yes	No	
Remarks:						
	Checked by Contractor	Certified by Consultant	Witnessed by JBALB Representative			
Name						
Signature						
Designation						
Date						



**TESTING AND COMMISSIONING  
PLAN FOR WATER TREATMENT  
PLANT**

Contract No:

Rev: 1

Date:

**COMMISSIONING CHECKLISTS FOR WATER TREATMENT PLANT**

Project Name :	Capacity : m3/hr					
Work Contract No. :	Operation : hr/d					
<b>AIR BLOWERS</b>						
1. Manufacturers start-up procedure complete	Unit	Yes	No			
	Blower					
	Blower					
2.	Measure current consumption under load (A)					
Unit	Rated D. Pressure (kPA)	Actual D. Pressure (kPA)	Rated FLC (A)	Measured FLC (A)		
Blower				R	Y	B
Blower						
3. Blower Speed	Satisfactory			Yes	No	
	Unit	Rated Flow Rate (m <sup>3</sup> /h)	Actual Flow Rate (m <sup>3</sup> /h)			
	Blower					
	Blower					
4.	Remote start checked			Yes	No	
5. Check operation of air relief valves	Unit	Rated Relief Pressure (kPA)	Actual Relief Pressure (Kpa)			
	Blower					
	Blower					
6. Measure noise level (1m)	Blower			dBA		
	Blower			dBA		
	Checked by Contractor	Certified by Consultant	Witnessed by JBALB Representative			
Name						
Signature						
Designation						
Date						



**TESTING AND COMMISSIONING  
PLAN FOR WATER TREATMENT  
PLANT**

Contract No:

Rev: 1

Date:

**COMMISSIONING CHECKLISTS FOR WATER TREATMENT PLANT**

Project Name :		Capacity :		m3/hr		
Work Contract No. :		Operation :		hr/d		
<b>MOTIVE WATER PUMP</b>						
1.	Manufacturer pre-start checks complete		Yes	No		
		Pump				
		Pump				
2.	Check current consumption under operating conditions: 5 eductors in service					
Unit No.	Rated FLC (A)	Measured FLC (A)			Discharge Pressure (kPA)	Discharge Flowrate (kPA)
		R	Y	B		
Pump						
Pump						
3.	Check pump controls: Low level shut-off:					
	Unit No.		Level in Balance Tank			
	Pump					
	Pump					
4.	Check discharge pressure with educator in service.					
	Unit No.	3 Eductor	4 Eductor	5 Eductor		
	Pump					
	Pump					
	Checked by Contractor		Certified by Consultant		Witnessed by JBALB Representative	
Name						
Signature						
Designation						
Date						



**TESTING AND COMMISSIONING  
PLAN FOR WATER TREATMENT  
PLANT**

Contract No:

Rev: 1

Date:

**COMMISSIONING CHECKLISTS FOR WATER TREATMENT PLANT**

Project Name :	Capacity : m3/hr
Work Contract No. :	Operation : hr/d

**SLUDGE TANK**

1.	Manufacturer pre-start checks complete	Yes	No																												
2.	Run each pump for approximately 60 minutes to check current consumption	<table border="1"> <thead> <tr> <th rowspan="2">Unit No.</th> <th rowspan="2">Rated FLC (A)</th> <th colspan="3">Measured FLC (A)</th> </tr> <tr> <th>R</th> <th>Y</th> <th>B</th> </tr> </thead> <tbody> <tr> <td>Pump</td> <td></td> <td></td> <td></td> <td></td> </tr> <tr> <td>Pump</td> <td></td> <td></td> <td></td> <td></td> </tr> <tr> <td></td> <td></td> <td></td> <td></td> <td></td> </tr> <tr> <td></td> <td></td> <td></td> <td></td> <td></td> </tr> </tbody> </table>		Unit No.	Rated FLC (A)	Measured FLC (A)			R	Y	B	Pump					Pump														
Unit No.	Rated FLC (A)	Measured FLC (A)																													
		R	Y	B																											
Pump																															
Pump																															
3.	Run pumps to low level in order to check automatic shut off; level at shut off.																														
4.	Check pump discharge capacity by volumetric method	<table border="1"> <thead> <tr> <th></th> <th>Pump</th> <th>Pump</th> </tr> </thead> <tbody> <tr> <td>Time Interval</td> <td align="center">hours</td> <td align="center">hours</td> </tr> <tr> <td>Draw down volume</td> <td align="center">m<sup>3</sup></td> <td align="center">m<sup>3</sup></td> </tr> <tr> <td>Estimated flow rate</td> <td align="center">m<sup>3</sup>/h</td> <td align="center">m<sup>3</sup>/h</td> </tr> </tbody> </table>			Pump	Pump	Time Interval	hours	hours	Draw down volume	m <sup>3</sup>	m <sup>3</sup>	Estimated flow rate	m <sup>3</sup> /h	m <sup>3</sup> /h																
	Pump	Pump																													
Time Interval	hours	hours																													
Draw down volume	m <sup>3</sup>	m <sup>3</sup>																													
Estimated flow rate	m <sup>3</sup> /h	m <sup>3</sup> /h																													
	Commissioning complete, system ready to use.	Yes	No																												

	Checked by Contractor	Certified by Consultant	Witnessed by JBALB Representative
Name			
Signature			
Designation			
Date			



**TESTING AND COMMISSIONING  
PLAN FOR WATER TREATMENT  
PLANT**

Contract No:

Rev: 1

Date:

**COMMISSIONING CHECKLISTS FOR WATER TREATMENT PLANT**

Project Name :	Capacity : m3/hr
Work Contract No. :	Operation : hr/d

**ALUM DOSING SYSTEM**

1. Fill mixing tanks; check operation of mixer

Unit	Rated FLC (A)	Measured FLC (A)			Rated Speed (RPM)	Measure Speed (RPM)
		R	Y	B		
Mixer						
Mixer						

2. Measure usable volume

Unit	Length	Width	Depth	Volume
Tank				
Tank				

3. Fill constant head tank; connect system to appropriate educator; check capacity is sufficient for full flow meter reading

Satisfactory

Unit	Yes	No
Educator		
Educator		

Commissioning complete, system ready to use.

Yes	No

Remarks:

	Checked by Contractor	Certified by Consultant	Witnessed by JBALB Representative
Name			
Signature			
Designation			
Date			



**TESTING AND COMMISSIONING  
PLAN FOR WATER TREATMENT  
PLANT**

Contract No:

Rev: 1

Date:

**COMMISSIONING CHECKLISTS FOR WATER TREATMENT PLANT**

Project Name :	Capacity : m3/hr
Work Contract No. :	Operation : hr/d

**SODA ASH DOSING SYSTEM**

1. Fill mixing tanks; check operation of Feeders, vibrators, and mixer motors.

Unit	Rated FLC (A)	Measured FLC (A)		
		R	Y	B
Feeder				
Feeder				
Mixer				
Mixer				
Vibrator				
Vibrator				

2. Check mixer speeds

Unit	Rated Speed (RPM)	Measured Speed (RPM)
Mixer		
Mixer		

3. Vibrator operation checks

Unit No.	Interval Set	Interval Measured	Duration Set	Duration Measured
Vibrator				
Vibrator				

4. Heater operation check

Unit No.	Temperature Set (°C)
Heater	
Heater	

Unit No	Rated Current (A)	Measured Current (A)
Heater		
Heater		



**TESTING AND COMMISSIONING  
PLAN FOR WATER TREATMENT  
PLANT**

Contract No:

Rev: 1

Date:

**COMMISSIONING CHECKLISTS FOR WATER TREATMENT PLANT**

Project Name :	Capacity : m3/hr																										
Work Contract No. :	Operation : hr/d																										
<p>5. Check calibration of powder feeders.</p> <p>6. Connect systems to appropriate educators and check educator capacity is sufficient for maximum weir settings</p> <p style="text-align: center;">Satisfactory</p> <table border="1" style="margin-left: auto; margin-right: auto;"> <thead> <tr> <th style="width: 20%;">System</th> <th style="width: 20%;">Yes</th> <th style="width: 20%;">No</th> </tr> </thead> <tbody> <tr> <td>No.</td> <td></td> <td></td> </tr> <tr> <td>No.</td> <td></td> <td></td> </tr> </tbody> </table> <p>7. Check operation of dust collection system.</p> <table border="1" style="margin-left: auto; margin-right: auto;"> <thead> <tr> <th rowspan="2" style="width: 15%;">Unit</th> <th rowspan="2" style="width: 15%;">Rated FLC (A)</th> <th colspan="3" style="width: 30%;">Measured FLC (A)</th> </tr> <tr> <th style="width: 10%;">R</th> <th style="width: 10%;">Y</th> <th style="width: 10%;">B</th> </tr> </thead> <tbody> <tr> <td>Fan motor</td> <td></td> <td></td> <td></td> <td></td> </tr> </tbody> </table> <p style="text-align: center;">Commissioning complete, system ready for use.</p> <table border="1" style="margin-left: auto; margin-right: auto;"> <thead> <tr> <th style="width: 20%;">Yes</th> <th style="width: 20%;">No</th> </tr> </thead> <tbody> <tr> <td></td> <td></td> </tr> </tbody> </table>		System	Yes	No	No.			No.			Unit	Rated FLC (A)	Measured FLC (A)			R	Y	B	Fan motor					Yes	No		
System	Yes	No																									
No.																											
No.																											
Unit	Rated FLC (A)	Measured FLC (A)																									
		R	Y	B																							
Fan motor																											
Yes	No																										
Remarks:																											
	Checked by Contractor	Certified by Consultant	Witnessed by JBALB Representative																								
Name																											
Signature																											
Designation																											
Date																											



**TESTING AND COMMISSIONING  
PLAN FOR WATER TREATMENT  
PLANT**

Contract No:

Rev: 1

Date:

**COMMISSIONING CHECKLISTS FOR WATER TREATMENT PLANT**

Project Name :	Capacity : m3/hr												
Work Contract No. :	Operation : hr/d												
<b>CHLORINE DOSING SYSTEM</b>													
1. Check all gas pipework joints for leaks using ammonia vapor.	<table border="1" style="margin-left: auto; margin-right: auto;"> <tr> <td style="width: 50px;"></td> <td style="width: 50px; text-align: center;">Yes</td> <td style="width: 50px; text-align: center;">No</td> </tr> <tr> <td></td> <td></td> <td></td> </tr> </table>		Yes	No									
	Yes	No											
2. Manufacturers pre-start up checks complete	<table border="1" style="margin-left: auto; margin-right: auto;"> <tr> <td style="width: 50px;"></td> <td style="width: 50px; text-align: center;">Yes</td> <td style="width: 50px; text-align: center;">No</td> </tr> <tr> <td></td> <td></td> <td></td> </tr> </table>		Yes	No									
	Yes	No											
Satisfactory	<table border="1" style="margin-left: auto; margin-right: auto;"> <tr> <td style="width: 50px;">Unit</td> <td style="width: 50px; text-align: center;">Yes</td> <td style="width: 50px; text-align: center;">No</td> </tr> <tr> <td>Chlorine Dosing</td> <td></td> <td></td> </tr> <tr> <td>Chlorine Dosing</td> <td></td> <td></td> </tr> <tr> <td>Chlorine Dosing</td> <td></td> <td></td> </tr> </table>	Unit	Yes	No	Chlorine Dosing			Chlorine Dosing			Chlorine Dosing		
Unit	Yes	No											
Chlorine Dosing													
Chlorine Dosing													
Chlorine Dosing													
3. Check operation changeover panel.	<table border="1" style="margin-left: auto; margin-right: auto;"> <tr> <td style="width: 50px;"></td> <td style="width: 50px; text-align: center;">Yes</td> <td style="width: 50px; text-align: center;">No</td> </tr> <tr> <td></td> <td></td> <td></td> </tr> </table>		Yes	No									
	Yes	No											
Commissioning complete, system ready for use.	<table border="1" style="margin-left: auto; margin-right: auto;"> <tr> <td style="width: 50px;"></td> <td style="width: 50px; text-align: center;">Yes</td> <td style="width: 50px; text-align: center;">No</td> </tr> <tr> <td></td> <td></td> <td></td> </tr> </table>		Yes	No									
	Yes	No											
	<table border="1" style="margin-left: auto; margin-right: auto;"> <tr> <td style="width: 50px;"></td> <td style="width: 50px; text-align: center;">Yes</td> <td style="width: 50px; text-align: center;">No</td> </tr> <tr> <td></td> <td></td> <td></td> </tr> </table>		Yes	No									
	Yes	No											
	<table border="1" style="margin-left: auto; margin-right: auto;"> <tr> <td style="width: 50px;"></td> <td style="width: 50px; text-align: center;">Yes</td> <td style="width: 50px; text-align: center;">No</td> </tr> <tr> <td></td> <td></td> <td></td> </tr> </table>		Yes	No									
	Yes	No											
	<table border="1" style="margin-left: auto; margin-right: auto;"> <tr> <td style="width: 50px;"></td> <td style="width: 50px; text-align: center;">Yes</td> <td style="width: 50px; text-align: center;">No</td> </tr> <tr> <td></td> <td></td> <td></td> </tr> </table>		Yes	No									
	Yes	No											
	<table border="1" style="margin-left: auto; margin-right: auto;"> <tr> <td style="width: 50px;"></td> <td style="width: 50px; text-align: center;">Yes</td> <td style="width: 50px; text-align: center;">No</td> </tr> <tr> <td></td> <td></td> <td></td> </tr> </table>		Yes	No									
	Yes	No											
	<table border="1" style="margin-left: auto; margin-right: auto;"> <tr> <td style="width: 50px;"></td> <td style="width: 50px; text-align: center;">Yes</td> <td style="width: 50px; text-align: center;">No</td> </tr> <tr> <td></td> <td></td> <td></td> </tr> </table>		Yes	No									
	Yes	No											
	<table border="1" style="margin-left: auto; margin-right: auto;"> <tr> <td style="width: 50px;"></td> <td style="width: 50px; text-align: center;">Yes</td> <td style="width: 50px; text-align: center;">No</td> </tr> <tr> <td></td> <td></td> <td></td> </tr> </table>		Yes	No									
	Yes	No											
	<table border="1" style="margin-left: auto; margin-right: auto;"> <tr> <td style="width: 50px;"></td> <td style="width: 50px; text-align: center;">Yes</td> <td style="width: 50px; text-align: center;">No</td> </tr> <tr> <td></td> <td></td> <td></td> </tr> </table>		Yes	No									
	Yes	No											
	<table border="1" style="margin-left: auto; margin-right: auto;"> <tr> <td style="width: 50px;"></td> <td style="width: 50px; text-align: center;">Yes</td> <td style="width: 50px; text-align: center;">No</td> </tr> <tr> <td></td> <td></td> <td></td> </tr> </table>		Yes	No									
	Yes	No											
	<table border="1" style="margin-left: auto; margin-right: auto;"> <tr> <td style="width: 50px;"></td> <td style="width: 50px; text-align: center;">Yes</td> <td style="width: 50px; text-align: center;">No</td> </tr> <tr> <td></td> <td></td> <td></td> </tr> </table>		Yes	No									
	Yes	No											
	<table border="1" style="margin-left: auto; margin-right: auto;"> <tr> <td style="width: 50px;"></td> <td style="width: 50px; text-align: center;">Yes</td> <td style="width: 50px; text-align: center;">No</td> </tr> <tr> <td></td> <td></td> <td></td> </tr> </table>		Yes	No									
	Yes	No											
	<table border="1" style="margin-left: auto; margin-right: auto;"> <tr> <td style="width: 50px;"></td> <td style="width: 50px; text-align: center;">Yes</td> <td style="width: 50px; text-align: center;">No</td> </tr> <tr> <td></td> <td></td> <td></td> </tr> </table>		Yes	No									
	Yes	No											
	<table border="1" style="margin-left: auto; margin-right: auto;"> <tr> <td style="width: 50px;"></td> <td style="width: 50px; text-align: center;">Yes</td> <td style="width: 50px; text-align: center;">No</td> </tr> <tr> <td></td> <td></td> <td></td> </tr> </table>		Yes	No									
	Yes	No											
	<table border="1" style="margin-left: auto; margin-right: auto;"> <tr> <td style="width: 50px;"></td> <td style="width: 50px; text-align: center;">Yes</td> <td style="width: 50px; text-align: center;">No</td> </tr> <tr> <td></td> <td></td> <td></td> </tr> </table>		Yes	No									
	Yes	No											
	<table border="1" style="margin-left: auto; margin-right: auto;"> <tr> <td style="width: 50px;"></td> <td style="width: 50px; text-align: center;">Yes</td> <td style="width: 50px; text-align: center;">No</td> </tr> <tr> <td></td> <td></td> <td></td> </tr> </table>		Yes	No									
	Yes	No											
	<table border="1" style="margin-left: auto; margin-right: auto;"> <tr> <td style="width: 50px;"></td> <td style="width: 50px; text-align: center;">Yes</td> <td style="width: 50px; text-align: center;">No</td> </tr> <tr> <td></td> <td></td> <td></td> </tr> </table>		Yes	No									
	Yes	No											
	<table border="1" style="margin-left: auto; margin-right: auto;"> <tr> <td style="width: 50px;"></td> <td style="width: 50px; text-align: center;">Yes</td> <td style="width: 50px; text-align: center;">No</td> </tr> <tr> <td></td> <td></td> <td></td> </tr> </table>		Yes	No									
	Yes	No											
	<table border="1" style="margin-left: auto; margin-right: auto;"> <tr> <td style="width: 50px;"></td> <td style="width: 50px; text-align: center;">Yes</td> <td style="width: 50px; text-align: center;">No</td> </tr> <tr> <td></td> <td></td> <td></td> </tr> </table>		Yes	No									
	Yes	No											
	<table border="1" style="margin-left: auto; margin-right: auto;"> <tr> <td style="width: 50px;"></td> <td style="width: 50px; text-align: center;">Yes</td> <td style="width: 50px; text-align: center;">No</td> </tr> <tr> <td></td> <td></td> <td></td> </tr> </table>		Yes	No									
	Yes	No											
	<table border="1" style="margin-left: auto; margin-right: auto;"> <tr> <td style="width: 50px;"></td> <td style="width: 50px; text-align: center;">Yes</td> <td style="width: 50px; text-align: center;">No</td> </tr> <tr> <td></td> <td></td> <td></td> </tr> </table>		Yes	No									
	Yes	No											
	<table border="1" style="margin-left: auto; margin-right: auto;"> <tr> <td style="width: 50px;"></td> <td style="width: 50px; text-align: center;">Yes</td> <td style="width: 50px; text-align: center;">No</td> </tr> <tr> <td></td> <td></td> <td></td> </tr> </table>		Yes	No									
	Yes	No											
	<table border="1" style="margin-left: auto; margin-right: auto;"> <tr> <td style="width: 50px;"></td> <td style="width: 50px; text-align: center;">Yes</td> <td style="width: 50px; text-align: center;">No</td> </tr> <tr> <td></td> <td></td> <td></td> </tr> </table>		Yes	No									
	Yes	No											
	<table border="1" style="margin-left: auto; margin-right: auto;"> <tr> <td style="width: 50px;"></td> <td style="width: 50px; text-align: center;">Yes</td> <td style="width: 50px; text-align: center;">No</td> </tr> <tr> <td></td> <td></td> <td></td> </tr> </table>		Yes	No									
	Yes	No											
	<table border="1" style="margin-left: auto; margin-right: auto;"> <tr> <td style="width: 50px;"></td> <td style="width: 50px; text-align: center;">Yes</td> <td style="width: 50px; text-align: center;">No</td> </tr> <tr> <td></td> <td></td> <td></td> </tr> </table>		Yes	No									
	Yes	No											
	<table border="1" style="margin-left: auto; margin-right: auto;"> <tr> <td style="width: 50px;"></td> <td style="width: 50px; text-align: center;">Yes</td> <td style="width: 50px; text-align: center;">No</td> </tr> <tr> <td></td> <td></td> <td></td> </tr> </table>		Yes	No									
	Yes	No											
	<table border="1" style="margin-left: auto; margin-right: auto;"> <tr> <td style="width: 50px;"></td> <td style="width: 50px; text-align: center;">Yes</td> <td style="width: 50px; text-align: center;">No</td> </tr> <tr> <td></td> <td></td> <td></td> </tr> </table>		Yes	No									
	Yes	No											
	<table border="1" style="margin-left: auto; margin-right: auto;"> <tr> <td style="width: 50px;"></td> <td style="width: 50px; text-align: center;">Yes</td> <td style="width: 50px; text-align: center;">No</td> </tr> <tr> <td></td> <td></td> <td></td> </tr> </table>		Yes	No									
	Yes	No											
	<table border="1" style="margin-left: auto; margin-right: auto;"> <tr> <td style="width: 50px;"></td> <td style="width: 50px; text-align: center;">Yes</td> <td style="width: 50px; text-align: center;">No</td> </tr> <tr> <td></td> <td></td> <td></td> </tr> </table>		Yes	No									
	Yes	No											
	<table border="1" style="margin-left: auto; margin-right: auto;"> <tr> <td style="width: 50px;"></td> <td style="width: 50px; text-align: center;">Yes</td> <td style="width: 50px; text-align: center;">No</td> </tr> <tr> <td></td> <td></td> <td></td> </tr> </table>		Yes	No									
	Yes	No											
	<table border="1" style="margin-left: auto; margin-right: auto;"> <tr> <td style="width: 50px;"></td> <td style="width: 50px; text-align: center;">Yes</td> <td style="width: 50px; text-align: center;">No</td> </tr> <tr> <td></td> <td></td> <td></td> </tr> </table>		Yes	No									
	Yes	No											
	<table border="1" style="margin-left: auto; margin-right: auto;"> <tr> <td style="width: 50px;"></td> <td style="width: 50px; text-align: center;">Yes</td> <td style="width: 50px; text-align: center;">No</td> </tr> <tr> <td></td> <td></td> <td></td> </tr> </table>		Yes	No									
	Yes	No											
	<table border="1" style="margin-left: auto; margin-right: auto;"> <tr> <td style="width: 50px;"></td> <td style="width: 50px; text-align: center;">Yes</td> <td style="width: 50px; text-align: center;">No</td> </tr> <tr> <td></td> <td></td> <td></td> </tr> </table>		Yes	No									
	Yes	No											
	<table border="1" style="margin-left: auto; margin-right: auto;"> <tr> <td style="width: 50px;"></td> <td style="width: 50px; text-align: center;">Yes</td> <td style="width: 50px; text-align: center;">No</td> </tr> <tr> <td></td> <td></td> <td></td> </tr> </table>		Yes	No									
	Yes	No											
	<table border="1" style="margin-left: auto; margin-right: auto;"> <tr> <td style="width: 50px;"></td> <td style="width: 50px; text-align: center;">Yes</td> <td style="width: 50px; text-align: center;">No</td> </tr> <tr> <td></td> <td></td> <td></td> </tr> </table>		Yes	No									
	Yes	No											
	<table border="1" style="margin-left: auto; margin-right: auto;"> <tr> <td style="width: 50px;"></td> <td style="width: 50px; text-align: center;">Yes</td> <td style="width: 50px; text-align: center;">No</td> </tr> <tr> <td></td> <td></td> <td></td> </tr> </table>		Yes	No									
	Yes	No											
	<table border="1" style="margin-left: auto; margin-right: auto;"> <tr> <td style="width: 50px;"></td> <td style="width: 50px; text-align: center;">Yes</td> <td style="width: 50px; text-align: center;">No</td> </tr> <tr> <td></td> <td></td> <td></td> </tr> </table>		Yes	No									
	Yes	No											
	<table border="1" style="margin-left: auto; margin-right: auto;"> <tr> <td style="width: 50px;"></td> <td style="width: 50px; text-align: center;">Yes</td> <td style="width: 50px; text-align: center;">No</td> </tr> <tr> <td></td> <td></td> <td></td> </tr> </table>		Yes	No									
	Yes	No											
	<table border="1" style="margin-left: auto; margin-right: auto;"> <tr> <td style="width: 50px;"></td> <td style="width: 50px; text-align: center;">Yes</td> <td style="width: 50px; text-align: center;">No</td> </tr> <tr> <td></td> <td></td> <td></td> </tr> </table>		Yes	No									
	Yes	No											
	<table border="1" style="margin-left: auto; margin-right: auto;"> <tr> <td style="width: 50px;"></td> <td style="width: 50px; text-align: center;">Yes</td> <td style="width: 50px; text-align: center;">No</td> </tr> <tr> <td></td> <td></td> <td></td> </tr> </table>		Yes	No									
	Yes	No											
	<table border="1" style="margin-left: auto; margin-right: auto;"> <tr> <td style="width: 50px;"></td> <td style="width: 50px; text-align: center;">Yes</td> <td style="width: 50px; text-align: center;">No</td> </tr> <tr> <td></td> <td></td> <td></td> </tr> </table>		Yes	No									
	Yes	No											
	<table border="1" style="margin-left: auto; margin-right: auto;"> <tr> <td style="width: 50px;"></td> <td style="width: 50px; text-align: center;">Yes</td> <td style="width: 50px; text-align: center;">No</td> </tr> <tr> <td></td> <td></td> <td></td> </tr> </table>		Yes	No									
	Yes	No											
	<table border="1" style="margin-left: auto; margin-right: auto;"> <tr> <td style="width: 50px;"></td> <td style="width: 50px; text-align: center;">Yes</td> <td style="width: 50px; text-align: center;">No</td> </tr> <tr> <td></td> <td></td> <td></td> </tr> </table>		Yes	No									
	Yes	No											
	<table border="1" style="margin-left: auto; margin-right: auto;"> <tr> <td style="width: 50px;"></td> <td style="width: 50px; text-align: center;">Yes</td> <td style="width: 50px; text-align: center;">No</td> </tr> <tr> <td></td> <td></td> <td></td> </tr> </table>		Yes	No									
	Yes	No											
	<table border="1" style="margin-left: auto; margin-right: auto;"> <tr> <td style="width: 50px;"></td> <td style="width: 50px; text-align: center;">Yes</td> <td style="width: 50px; text-align: center;">No</td> </tr> <tr> <td></td> <td></td> <td></td> </tr> </table>		Yes	No									
	Yes	No											
	<table border="1" style="margin-left: auto; margin-right: auto;"> <tr> <td style="width: 50px;"></td> <td style="width: 50px; text-align: center;">Yes</td> <td style="width: 50px; text-align: center;">No</td> </tr> <tr> <td></td> <td></td> <td></td> </tr> </table>		Yes	No									
	Yes	No											
	<table border="1" style="margin-left: auto; margin-right: auto;"> <tr> <td style="width: 50px;"></td> <td style="width: 50px; text-align: center;">Yes</td> <td style="width: 50px; text-align: center;">No</td> </tr> <tr> <td></td> <td></td> <td></td> </tr> </table>		Yes	No									
	Yes	No											
	<table border="1" style="margin-left: auto; margin-right: auto;"> <tr> <td style="width: 50px;"></td> <td style="width: 50px; text-align: center;">Yes</td> <td style="width: 50px; text-align: center;">No</td> </tr> <tr> <td></td> <td></td> <td></td> </tr> </table>		Yes	No									
	Yes	No											
	<table border="1" style="margin-left: auto; margin-right: auto;"> <tr> <td style="width: 50px;"></td> <td style="width: 50px; text-align: center;">Yes</td> <td style="width: 50px; text-align: center;">No</td> </tr> <tr> <td></td> <td></td> <td></td> </tr> </table>		Yes	No									
	Yes	No											
	<table border="1" style="margin-left: auto; margin-right: auto;"> <tr> <td style="width: 50px;"></td> <td style="width: 50px; text-align: center;">Yes</td> <td style="width: 50px; text-align: center;">No</td> </tr> <tr> <td></td> <td></td> <td></td> </tr> </table>		Yes	No									
	Yes	No											
	<table border="1" style="margin-left: auto; margin-right: auto;"> <tr> <td style="width: 50px;"></td> <td style="width: 50px; text-align: center;">Yes</td> <td style="width: 50px; text-align: center;">No</td> </tr> <tr> <td></td> <td></td> <td></td> </tr> </table>		Yes	No									
	Yes	No											
	<table border="1" style="margin-left: auto; margin-right: auto;"> <tr> <td style="width: 50px;"></td> <td style="width: 50px; text-align: center;">Yes</td> <td style="width: 50px; text-align: center;">No</td> </tr> <tr> <td></td> <td></td> <td></td> </tr> </table>		Yes	No									
	Yes	No											
	<table border="1" style="margin-left: auto; margin-right: auto;"> <tr> <td style="width: 50px;"></td> <td style="width: 50px; text-align: center;">Yes</td> <td style="width: 50px; text-align: center;">No</td> </tr> <tr> <td></td> <td></td> <td></td> </tr> </table>		Yes	No									
	Yes	No											
	<table border="1" style="margin-left: auto; margin-right: auto;"> <tr> <td style="width: 50px;"></td> <td style="width: 50px; text-align: center;">Yes</td> <td style="width: 50px; text-align: center;">No</td> </tr> <tr> <td></td> <td></td> <td></td> </tr> </table>		Yes	No									
	Yes	No											
	<table border="1" style="margin-left: auto; margin-right: auto;"> <tr> <td style="width: 50px;"></td> <td style="width: 50px; text-align: center;">Yes</td> <td style="width: 50px; text-align: center;">No</td> </tr> <tr> <td></td> <td></td> <td></td> </tr> </table>		Yes	No									
	Yes	No											
	<table border="1" style="margin-left: auto; margin-right: auto;"> <tr> <td style="width: 50px;"></td> <td style="width: 50px; text-align: center;">Yes</td> <td style="width: 50px; text-align: center;">No</td> </tr> <tr> <td></td> <td></td> <td></td> </tr> </table>		Yes	No									
	Yes	No											
	<table border="1" style="margin-left: auto; margin-right: auto;"> <tr> <td style="width: 50px;"></td> <td style="width: 50px; text-align: center;">Yes</td> <td style="width: 50px; text-align: center;">No</td> </tr> <tr> <td></td> <td></td> <td></td> </tr> </table>		Yes	No									
	Yes	No											
	<table border="1" style="margin-left: auto; margin-right: auto;"> <tr> <td style="width: 50px;"></td> <td style="width: 50px; text-align: center;">Yes</td> <td style="width: 50px; text-align: center;">No</td> </tr> <tr> <td></td> <td></td> <td></td> </tr> </table>		Yes	No									
	Yes	No											
	<table border="1" style="margin-left: auto; margin-right: auto;"> <tr> <td style="width: 50px;"></td> <td style="width: 50px; text-align: center;">Yes</td> <td style="width: 50px; text-align: center;">No</td> </tr> <tr> <td></td> <td></td> <td></td> </tr> </table>		Yes	No									
	Yes	No											
	<table border="1" style="margin-left: auto; margin-right: auto;"> <tr> <td style="width: 50px;"></td> <td style="width: 50px; text-align: center;">Yes</td> <td style="width: 50px; text-align: center;">No</td> </tr> <tr> <td></td> <td></td> <td></td> </tr> </table>		Yes	No									
	Yes	No											
	<table border="1" style="margin-left: auto; margin-right: auto;"> <tr> <td style="width: 50px;"></td> <td style="width: 50px; text-align: center;">Yes</td> <td style="width: 50px; text-align: center;">No</td> </tr> <tr> <td></td> <td></td> <td></td> </tr> </table>		Yes	No									
	Yes	No											
	<table border="1" style="margin-left: auto; margin-right: auto;"> <tr> <td style="width: 50px;"></td> <td style="width: 50px; text-align: center;">Yes</td> <td style="width: 50px; text-align: center;">No</td> </tr> <tr> <td></td> <td></td> <td></td> </tr> </table>		Yes	No									
	Yes	No											
	<table border="1" style="margin-left: auto; margin-right: auto;"> <tr> <td style="width: 50px;"></td> <td style="width: 50px; text-align: center;">Yes</td> <td style="width: 50px; text-align: center;">No</td> </tr> <tr> <td></td> <td></td> <td></td> </tr> </table>		Yes	No									
	Yes	No											
	<table border="1" style="margin-left: auto; margin-right: auto;"> <tr> <td style="width: 50px;"></td> <td style="width: 50px; text-align: center;">Yes</td> <td style="width: 50px; text-align: center;">No</td> </tr> <tr> <td></td> <td></td> <td></td> </tr> </table>		Yes	No									
	Yes	No											
	<table border="1" style="margin-left: auto; margin-right: auto;"> <tr> <td style="width: 50px;"></td> <td style="width: 50px; text-align: center;">Yes</td> <td style="width: 50px; text-align: center;">No</td> </tr> <tr> <td></td> <td></td> <td></td> </tr> </table>		Yes	No									
	Yes	No											
	<table border="1" style="margin-left: auto; margin-right: auto;"> <tr> <td style="width: 50px;"></td> <td style="width: 50px; text-align: center;">Yes</td> <td style="width: 50px; text-align: center;">No</td> </tr> <tr> <td></td> <td></td> <td></td> </tr> </table>		Yes	No									
	Yes	No											
	<table border="1" style="margin-left: auto; margin-right: auto;"> <tr> <td style="width: 50px;"></td> <td style="width: 50px; text-align: center;">Yes</td> <td style="width: 50px; text-align: center;">No</td> </tr> <tr> <td></td> <td></td> <td></td> </tr> </table>		Yes	No									
	Yes	No											
	<table border="1" style="margin-left: auto; margin-right: auto;"> <tr> <td style="width: 50px;"></td> <td style="width: 50px; text-align: center;">Yes</td> <td style="width: 50px; text-align: center;">No</td> </tr> <tr> <td></td> <td></td> <td></td> </tr> </table>		Yes	No									
	Yes	No											
	<table border="1" style="margin-left: auto; margin-right: auto;"> <tr> <td style="width: 50px;"></td> <td style="width: 50px; text-align: center;">Yes</td> <td style="width: 50px; text-align: center;">No</td> </tr> <tr> <td></td> <td></td> <td></td> </tr> </table>		Yes	No									
	Yes	No											
	<table border="1" style="margin-left: auto; margin-right: auto;"> <tr> <td style="width: 50px;"></td> <td style="width: 50px; text-align: center;">Yes</td> <td style="width: 50px; text-align: center;">No</td> </tr> <tr> <td></td> <td></td> <td></td> </tr> </table>		Yes	No									
	Yes	No											
	<table border="1" style="margin-left: auto; margin-right: auto;"> <tr> <td style="width: 50px;"></td> <td style="width: 50px; text-align: center;">Yes</td> <td style="width: 50px; text-align: center;">No</td> </tr> <tr> <td></td> <td></td> <td></td> </tr> </table>		Yes	No									
	Yes	No											
	<table border="1" style="margin-left: auto; margin-right: auto;"> <tr> <td style="width: 50px;"></td> <td style="width: 50px; text-align: center;">Yes</td> <td style="width: 50px; text-align: center;">No</td> </tr> <tr> <td></td> <td></td> <td></td> </tr> </table>		Yes	No									
	Yes	No											
	<table border="1" style="margin-left: auto; margin-right: auto;"> <tr> <td style="width: 50px;"></td> <td style="width: 50px; text-align: center;">Yes</td> <td style="width: 50px; text-align: center;">No</td> </tr> <tr> <td></td> <td></td> <td></td> </tr> </table>		Yes	No									
	Yes	No											
	<table border="1" style="margin-left: auto; margin-right: auto;"> <tr> <td style="width: 50px;"></td> <td style="width: 50px; text-align: center;">Yes</td> <td style="width: 50px; text-align: center;">No</td> </tr> <tr> <td></td> <td></td> <td></td> </tr> </table>		Yes	No									
	Yes	No											
	<table border="1" style="margin-left: auto; margin-right: auto;"> <tr> <td style="width: 50px;"></td> <td style="width: 50px; text-align: center;">Yes</td> <td style="width: 50px; text-align: center;">No</td> </tr> <tr> <td></td> <td></td> <td></td> </tr> </table>		Yes	No									
	Yes	No											
	<table border="1" style="margin-left: auto; margin-right: auto;"> <tr> <td style="width: 50px;"></td> <td style="width: 50px; text-align: center;">Yes</td> <td style="width: 50px; text-align: center;">No</td> </tr> <tr> <td></td> <td></td> <td></td> </tr> </table>		Yes	No									
	Yes	No											
	<table border="1" style="margin-left: auto; margin-right: auto;"> <tr> <td style="width: 50px;"></td> <td style="width: 50px; text-align: center;">Yes</td> <td style="width: 50px; text-align: center;">No</td> </tr> <tr> <td></td> <td></td> <td></td> </tr> </table>		Yes	No									
	Yes	No											
	<table border="1" style="margin-left: auto; margin-right: auto;"> <tr> <td style="width: 50px;"></td> <td style="width: 50px; text-align: center;">Yes</td> <td style="width: 50px; text-align: center;">No</td> </tr> <tr> <td></td> <td></td> <td></td> </tr> </table>		Yes	No									
	Yes	No											
	<table border="1" style="margin-left: auto; margin-right: auto;"> <tr> <td style="width: 50px;"></td> <td style="width: 50px; text-align: center;">Yes</td> <td style="width: 50px; text-align: center;">No</td> </tr> <tr> <td></td> <td></td> <td></td> </tr> </table>		Yes	No									
	Yes	No											
	<table border="1" style="margin-left: auto; margin-right: auto;"> <tr> <td style="width: 50px;"></td> <td style="width: 50px; text-align: center;">Yes</td> <td style="width: 50px; text-align: center;">No</td> </tr> <tr> <td></td> <td></td> <td></td> </tr> </table>		Yes	No									
	Yes	No											
	<table border="1" style="margin-left: auto; margin-right: auto;"> <tr> <td style="width: 50px;"></td> <td style="width: 50px; text-align: center;">Yes</td> <td style="width: 50px; text-align: center;">No</td> </tr> <tr> <td></td> <td></td> <td></td> </tr> </table>		Yes	No									
	Yes	No											
	<table border="1" style="margin-left: auto; margin-right: auto;"> <tr> <td style="width: 50px;"></td> <td style="width: 50px; text-align: center;">Yes</td> <td style="width: 50px; text-align: center;">No</td> </tr> <tr> <td></td> <td></td> <td></td> </tr> </table>		Yes	No									
	Yes	No											
	<table border="1" style="margin-left: auto; margin-right: auto;"> <tr> <td style="width: 50px;"></td> <td style="width: 50px; text-align: center;">Yes</td> <td style="width: 50px; text-align: center;">No</td> </tr> <tr> <td></td> <td></td> <td></td> </tr> </table>		Yes	No									
	Yes	No											
	<table border="1" style="margin-left: auto; margin-right: auto;"> <tr> <td style="width: 50px;"></td> <td style="width: 50px; text-align: center;">Yes</td> <td style="width: 50px; text-align: center;">No</td> </tr> <tr> <td></td> <td></td> <td></td> </tr> </table>		Yes	No									
	Yes	No											
	<table border="1" style="margin-left: auto; margin-right: auto;"> <tr> <td style="width: 50px;"></td> <td style="width: 50px; text-align: center;">Yes</td> <td style="width: 50px; text-align: center;">No</td> </tr> <tr> <td></td> <td></td> <td></td> </tr> </table>		Yes	No									
	Yes	No											
	<table border="1" style="margin-left: auto; margin-right: auto;"> <tr> <td style="width: 50px;"></td> <td style="width: 50px; text-align: center;">Yes</td> <td style="width: 50px; text-align: center;">No</td> </tr> <tr> <td></td> <td></td> <td></td> </tr> </table>		Yes	No									
	Yes	No											
	<table border="1" style="margin-left: auto; margin-right: auto;"> <tr> <td style="width: 50px;"></td> <td style="width: 50px; text-align: center;">Yes</td> <td style="width: 50px; text-align: center;">No</td> </tr> <tr> <td></td> <td></td> <td></td> </tr> </table>		Yes	No									
	Yes	No											
	<table border="1" style="margin-left: auto; margin-right: auto;"> <tr> <td style="width: 50px;"></td> <td style="width: 50px; text-align: center;">Yes</td> <td style="width: 50px; text-align: center;">No</td> </tr> <tr> <td></td> <td></td> <td></td> </tr> </table>		Yes	No									
	Yes	No											
	<table border="1" style="margin-left: auto; margin-right: auto;"> <tr> <td style="width: 50px;"></td> <td style="width: 50px; text-align: center;">Yes</td> </tr></table>		Yes										
	Yes												



**TESTING AND COMMISSIONING  
PLAN FOR WATER TREATMENT  
PLANT**

Contract No:

Rev: 1

Date:

**COMMISSIONING CHECKLISTS FOR WATER TREATMENT PLANT**

Project Name :	Capacity :	m3/hr
Work Contract No. :	Operation :	hr/d

**OVERHEAD TRAVELLING CRANE**

		Yes	No
1.	Alignment check complete		
2.	Manufacturers test certificate attached		
3.	Vertical deflection test of crane bridge caused by hoist plus Safe Working Load (SWL) in central position. Span Permitted maximum deflection (span – 750) Measured deflection	To Be Inspected by JKKP	
4.	Load hook through full travel with Safe Working Load		
5.	Crane travelled full length with Safe Working Load	Yes	No
6.	JKKP type approval		
7.	JKKP installation approval & Certificate (See Attached Certificate)		
Commissioning complete, system ready for use.		<b>Yes</b>	<b>No</b>

Remarks:

	Checked by Contractor	Certified by Consultant	Witnessed by JBALB Representative
Name			
Signature			
Designation			
Date			



**TESTING AND COMMISSIONING  
PLAN FOR WATER TREATMENT  
PLANT**

Contract No:

Rev: 1

Date:

**COMMISSIONING CHECKLISTS FOR WATER TREATMENT PLANT**

Project Name :	Capacity : m3/hr
Work Contract No. :	Operation : hr/d

**GENERATORS**

1. Manufacturers test certificate attached
2. D.O.E Application
3. Oil pressure switch operation
4. Water temperature switch operation
5. Engine over-speed switch operation
6. Trip-on control circuit voltage failure
7. Noise measured (in dBA)  
Measured 3 m from exhaust  
Measured 3 m from outer wall

Yes	No
Rated	Actual
kPA	kPA
°C	°C
rpm	rpm

North	South	East	West

8. Test generator over six consecutive starts

Yes	No

Commissioning complete, system ready for use.

Yes	No

Remarks:

	Checked by Contractor	Certified by Consultant	Witnessed by JBALB Representative
Name			
Signature			
Designation			
Date			



**TESTING AND COMMISSIONING  
PLAN FOR WATER TREATMENT  
PLANT**

Contract No:

Rev: 1

Date:

**COMMISSIONING CHECKLISTS FOR WATER TREATMENT PLANT**

Project Name :	Capacity :	m3/hr
Work Contract No. :	Operation :	hr/d

**SURGE SUPPRESSION EQUIPMENT**

(Where Surge Suppression Equipment fitted, commissioning will be carried out under section 2)

- a) Pump start up: Observed pressure
- b) Pump shut down: Observed pressure

Max	Min
Max	Min
Pressure Set Point:	
Level Set Point:	
bar	
m	

Yes	No

JKKP type approval

JKKP installation approval & Certificate (See Attached Certificate)

Commissioning completed.

Yes	No

Remarks:

	Checked by Contractor	Certified by Consultant	Witnessed by JBALB Representative
Name			
Signature			
Designation			
Date			



**TESTING AND COMMISSIONING  
PLAN FOR WATER TREATMENT  
PLANT**

Contract No:

Rev: 1

Date:

**COMMISSIONING CHECKLISTS FOR WATER TREATMENT PLANT**

Project Name :	Capacity : m3/hr
Work Contract No. :	Operation : hr/d

**CLARITY BOWL/SAMPLING SYSTEM**

*Pumps*

1.	Manufacturers pre-start checks complete	Units	Yes	No
		RW Pump		
		SW Pump		
		FW Pump		
		TW Pump		
2.	Run each pump for 10 minutes to check current consumption	Unit	Rated FLC (A)	Measured FLC (A)
		RW Pump		
		SW Pump		
		FW Pump		
		TW Pump		
3.	Run each pump for 60 minutes to checks running temperature, no mechanical seal leakage and no uncharacteristic noise or vibration			
4.	If sample points supplied by gravity, check discharge into clarity bowl is sufficient	Sample Point	Yes	No
		RW		
		SW		
		FW		
		TW		
Commissioning complete, system ready for use.			Yes	No

	Checked by Contractor	Certified by Consultant	Witnessed by JBALB Representative
Name			
Signature			
Designation			
Date			





**TESTING AND COMMISSIONING  
PLAN FOR WATER TREATMENT  
PLANT**

Contract No:

Rev: 1

Date:

**COMMISSIONING CHECKLISTS FOR WATER TREATMENT PLANT**

Project Name :	Capacity :	m <sup>3</sup> /hr
Work Contract No. :	Operation :	hr/d

**2. ANALOG INPUT/OUTPUT SIGNAL TO/FROM SCADA (PLC LOGIC TEST)**

**PROCEDURE**

1. Determine the loop is internally powered or externally powered from the schematic diagram.
2. Connect the + and – wires of the signal injector to the 4-20mA input terminals at...(Station Name).....Panel and set the signal injector according to the loop power condition.
3. Simulate the signal to 0%, 25%, 50%, 75%, 100% of the instrument range.

**TEST CRITERIA**

- The SCADA shall give the output signal according to signal simulated.

Equip. Description :  
 Simulated Range : 4 – 20 mA  
 Input Range :

	Simulated Range (mA)	Desired Value	Displayed Value	Remarks
	4			
	8			
	12			
	16			
	20			

Commissioning complete systems ready for use.

	Checked by Contractor	Certified by Consultant	Witnessed by JBALB Representative
Name			
Signature			
Designation			
Date			

	<b>TESTING AND COMMISSIONING PLAN FOR WATER TREATMENT PLANT</b>	Contract No:
		Rev: 1
		Date:

ACCEPTANCE TESTS FOR WATER TREATMENT PLANTS

**ACCEPTANCE TESTS FOR TREATMENT WORKS**



**TESTING AND COMMISSIONING  
PLAN FOR WATER TREATMENT  
PLANT**

Contract No:

Rev: 1

Date:

**ACCEPTANCE TESTS FOR WATER TREATMENT PLANTS**

**FILTER PERFORMANCE TESTS**

1. Establishment of Service Duration

Record head loss due to progressive clogging, and turbidity, commencing immediately after an extended backwash (to ensure clean media). See data sheet attached.

Filter No.		Bed Area	m <sup>2</sup>
Max head loss (Design)			m
Recommended Service Duration			hours
Head loss at end of Service Duration			m

2. Backwash Performance (as applicable)

2.1 Separate Air Scour/ Water Wash

Record Turbidity of wash water during backwash (see attached sheet)

	Design	Recommended
Air Scour Duration	minutes	minutes
Backwash Duration	minutes	minutes
Backwash Flow	m <sup>3</sup> /hr	m <sup>3</sup> /hr

2.2 Combined Air Water Scour/Water backwash

Record Turbidity of wash water during both sequences (see attached sheet)

	Design	Recommended
Air/Water Scour Duration	minutes	minutes
Air/Water Scour Flow	m <sup>3</sup> /hr	m <sup>3</sup> /hr
Wash Water Duration	minutes	minutes
Wash Water Flow	m <sup>3</sup> /hr	m <sup>3</sup> /hr



**TESTING AND COMMISSIONING  
PLAN FOR WATER TREATMENT  
PLANT**

Contract No:

Rev: 1

Date:

**ACCEPTANCE TESTS FOR WATER TREATMENT PLANTS**

**3. Performance Check for Multiple Filter Banks**

Check filters bank performance under conditions of increased unit flow due to filter washing in progress.

Total number of filter units		
Filter in service		
Filter undergoing wash sequence		
Plant flow		m <sup>3</sup> /hr
Normal flow per unit		m <sup>3</sup> /hr
Flow during wash sequence (max)		m <sup>3</sup> /hr
Filter under test		
Hours in service		
	Flow Normal	Flow Max
Turbidity of Influent		
Turbidity of Effluent		
Aluminium Cont. Influent		
Aluminium Cont. Effluent		



# TESTING AND COMMISSIONING PLAN FOR WATER TREATMENT PLANT

Contract No:

Rev: 1

Date:

## ACCEPTANCE TESTS FOR WATER TREATMENT PLANTS

### WATER QUALITY MONITORING

DATE: \_\_\_\_\_

Time Taken	RAW WATER						SETTLED WATER						FILTERED WATER						TREATED WATER																		
	Raw Water Inlet (m <sup>3</sup> /hr)	Dosage PAC (mg/l)	Dosage SodaAsh (mg/l)	Dosage Polymer (mg/l)	SOM (ECU)	Dosage Post-Solids (mg/L)	Dosage Post-Chlorine (mg/L)	pH	Colour (TCU)	Turbidity (NTU)	Aluminium (mg/L)	Iron (mg/L)	Manganese (mg/L)	pH	Colour (TCU)	Turbidity (NTU)	Aluminium (mg/L)	Iron (mg/L)	Manganese (mg/L)	pH	Colour (TCU)	Turbidity (NTU)	Aluminium (mg/L)	Iron (mg/L)	Manganese (mg/L)	Fluoride (mg/l)	Chlorine (mg/L)										
0000							5.5-9.0	300	1000	-	1.0	0.2	0.1	6.5-9.0	20.0	20.0	20.0	5.0	0.2	0.3	0.1	6.5-9.0	15.0	1.0	0.2	0.3	0.1	6.5-9.0	15.0	5.0	0.2	0.3	0.1	0.4-0.6	0.2-5.0		
0200																																					
0400																																					
0600																																					
0800																																					
1000																																					
1200																																					
1400																																					
1600																																					
1800																																					
2000																																					
2200																																					

NC = Not Check

Remarks:

Checked by Contractor	Certified by Consultant	Witnessed by JRF Representative
Name		
Signature		
Designation		
Date		



**TESTING AND COMMISSIONING  
PLAN FOR WATER TREATMENT  
PLANT**

Contract No:

Rev: 1

Date:

**ACCEPTANCE TESTS FOR WATER TREATMENT PLANTS**

Project Name :	Capacity :	m3/hr
Work Contract No. :	Operation :	hr/d

**JAR TEST REPORT**

Sample:	Date:
---------	-------

**Raw Water Quality**

pH	Al, mg/L
Turbidity, NTU	Iron, mg/L
Colour, Pt.Co	Mn, mg/L
Alkalinity, mg/L	

**Jar Test**

Jar No.	1	2	3	4	5	6
Pre-Soda Ash %, mg/L						
1st pH Reading						
Alum %, mg/L						
Coagulant Aid ( %), mg/L						
Rapid Mixing, rpm ( rpm)						
Flocculants % ppm						
Med Mixing, rpm ( rpm)						
Slow Mixing, rpm ( rpm)						
Water Settling Time ( ) min						
Floc Size						
Settled Water Turbidity, NTU						
Settled Water pH						
Settled Water Colour, Pt.Co						
Alkalinity, mg/L						
Residue Mn, mg/L						
Residue Iron, mg/L						
Residue Aluminium, mg/L						
Filtered Water Turbidity, mg/L						
Filtered Water Colour, Pt.Co						
Best Selection						

Comment :

	Checked by Contractor	Certified by Consultant	Witnessed by JBALB Representative
Name			
Signature			
Designation			
Date			





# TESTING AND COMMISSIONING PLAN FOR WATER TREATMENT PLANT

Contract No:
Rev: 1
Date:

**TABLE B: PUMP TEST CERTIFICATE** Unless otherwise specified Tests carried out in accordance with BS5316 Part 1, Class C

<b>PROJECT:</b>	<b>PUMP TESTED:</b>		
<b>DRIVER:</b>	<b>PUMP SIZE:</b>	<b>SERIAL NO:</b>	
<b>TYPE:</b>	<b>IMPELLER DIA:</b> MM	<b>INLET/OUTLET DIA:</b>	MM
<b>MAKE:</b>	<b>ORIFICE PLATE DIA:</b> MM		
<b>MODEL:</b> RPM:	<b>FLOW RATE:</b> m <sup>3</sup> /h		
<b>POWER:</b> CURRENT:	<b>TOTAL HEAD:</b> M		
<b>VOLTAGE:</b> PHASE:			

**SUCTION PRESSURE GAUGE LEVEL:** M  
**DISCHARGE PRESSURE GAUGE LEVEL:** M

TEST NO.	FLOW (m3/h)	DISCHARGE PRESSURE (M)	SUCTION PRESSURE (M)	V <sup>2</sup> /2g (M)	TDH (M)	VOLT (V)	AMP	P.F	MOTOR		PUMP			RPM
									INPUT POWER (kW)	EFF %	BHP kW	WHP kW	EFF %	

	Checked By Contractor	Certified by Consultant	Witnessed by JBALB Representative
Name			
Signature			
Designation			
Date			



**TESTING AND COMMISSIONING  
PLAN FOR WATER TREATMENT  
PLANT**

Contract No:

Rev: 1

Date:

**LIST OF EQUIPMENT**



**TESTING AND COMMISSIONING  
PLAN FOR WATER TREATMENT  
PLANT**

Contract No:

Rev: 1

Date:

**LIST OF EQUIPMENTS**

<b>1.</b>	<b>Raw Water Intake Pump</b>					
	Pump Brand/Make					
	Pump Model					
	Pump Serial No.					
	Pump Head	m				
	Design Flow Rate	m <sup>3</sup> /hr				
	HP					
	Power	kW				
	Rated current	A				
	Voltage/Phase	V/Phase				
	Motor Brand/Make					
	Motor Model					
	Motor Serial No.					
	Motor Speed	rpm				
	Motor Frequency	Hz				
Class						
<b>2.</b>	<b>Treated Water Pump</b>					
	Pump Brand/Make					
	Pump Model					
	Pump Serial No.					
	Pump Head	m				
	Design Flow Rate	m <sup>3</sup> /hr				
	HP					
	Power	kW				
	Rated current	A				
	Voltage/Phase	V/Phase				
	Motor Brand/Make					
	Motor Model					
	Motor Serial No.					
	Motor Speed	rpm				
	Motor Frequency	Hz				
Class						



**TESTING AND COMMISSIONING  
PLAN FOR WATER TREATMENT  
PLANT**

Contract No:

Rev: 1

Date:

<b>3.</b>	<b>Back Wash Water Pump</b>					
	Pump Brand/Make					
	Pump Model					
	Pump Serial No.					
	Pump Head	m				
	Design Flow Rate	m <sup>3</sup> /hr				
	HP					
	Power	kW				
	Rated current	A				
	Voltage/Phase	V/Phase				
	Motor Brand/Make					
	Motor Model					
	Motor Serial No.					
	Motor Speed	rpm				
	Motor Frequency	Hz				
	Class					
<b>4.</b>	<b>Air Blower</b>					
	Blower Brand/Make					
	Blower Model					
	Blower Serial No.					
	Blower Capacity	m <sup>3</sup> /hr				
	Blower Discharge Pressure	bar				
	Motor Brand/Make					
	Motor Model					
	Motor Serial No.					
	Motor Power	kW				
	Motor Rated current	A				
	Motor Voltage/Phase	V/Phase				
	Motor Speed	rpm				
	Motor Frequency	Hz				
	Class					



**TESTING AND COMMISSIONING  
PLAN FOR WATER TREATMENT  
PLANT**

Contract No:

Rev: 1

Date:

<b>5.</b>	<b>Sampling Pump</b>					
	Sample Type					
	Pump Brand/Make					
	Pump Model					
	Pump Serial No.					
	Pump Head	m				
	Design Flow Rate	l/min				
	Power	kW				
	Rated current	A				
	Voltage/Phase	V/Phase				
	Motor Speed	rpm				
	Motor Frequency	Hz				
	Class					
<b>6.</b>	<b>Chemical Dosing Pump</b>					
	Chemical Type					
	Pump Brand/Make					
	Pump Model					
	Pump Serial No.					
	Max Pressure	Bar				
	Max Flow Rate	l/hr				
	Rated current	A				
	Voltage/Phase	V/Phase				
	Motor Speed	rpm				
	Motor Frequency	Hz				
	Class					
<b>7.</b>	<b>Agitator/Mixer</b>					
	Chemical Type					
	Brand/Make					
	Model					
	Serial No.					
	Motor Brand/Make					
	Motor Model					
	Motor Power	kW				
	Motor Rated current	A				
	Voltage/Phase	V/Phase				
	Motor Speed	Rpm				
	Motor Frequency	Hz				
	Gear Model					
	Gear Speed	Rpm				



**TESTING AND COMMISSIONING  
PLAN FOR WATER TREATMENT  
PLANT**

Contract No:

Rev: 1

Date:

<b>8.</b>	<b>Monitoring Instruments</b>					
	Parameter monitored					
	Instrument Brand/Make					
	Instrument Model					
	Instrument Serial No.					
	Measure (ie pH, NTU,mg/l)					
	Output	mA				
	Rated current	A				
	Voltage/Phase	Voltage/Phase				
	Rated Frequency	Hz				
	Class					
<b>9.</b>	<b>Chlorination System</b>					
	9.1 <i>Vacuum Regulator</i>					
	Brand/Make					
	Type					
	Model					
	Heater Make					
	Heater Type					
	Power Rating	kW				
	Voltage/Frequency/Current	V/Hz/A				
	9.2 <i>Chlorinator</i>					
	Brand/Make					
	Type					
	Model					
	Max Capacity	kg/hr				
	Motor Make					
	Motor Type					
	Power Rating	kW				
	9.3 <i>Changeover Manifold</i>					
	Brand/Make					
	Type					
Serial No.						
Range						
9.4 <i>Injector</i>						
Brand/Make						
Type						
Serial No.						
Max Capacity	kg/hr					



**TESTING AND COMMISSIONING  
PLAN FOR WATER TREATMENT  
PLANT**

Contract No:

Rev: 1

Date:

<b>10.</b>	<b>Fluoride System</b>					
	Brand/Make					
	Model					
	Serial No.					
	Power Rating	kW				
	Class					
	Voltage/Frequency/Current	V/Hz/A				
<b>11.</b>	<b>Pressure Transmitter</b>					
	Instrument Brand/Make					
	Instrument Model					
	Instrument Serial No.					
	Measure (ie pH, NTU,mg/l)					
	Output	mA				
	Rated current	A				
	Voltage/Phase	V/Phase				
	Rated Frequency	Hz				
	Class					
<b>12</b>	<b>Crane</b>					
	Brand/Make					
	Type					
	Model					
	Country					
	Year					
	Equipment Serial No.					
	Hoist Serial No.					
	PMA Registration No.					
	Hoisting Capacity	Ton				
<b>13.</b>	<b>Sludge Collector</b>					
	Type					
	Brand/Make					
	Model					
	Serial No.					
	Speed	Rpm				
	Power	kW				
	Rated Current	A				



**TESTING AND COMMISSIONING  
PLAN FOR WATER TREATMENT  
PLANT**

Contract No:

Rev: 1

Date:

<b>14.</b>	<b>Air Compressor</b>					
	14.1	<i>Compressor</i>				
		Brand/Make				
		Model				
		Serial No.				
		Piston Displacement				
		Max Discharge Pressure	Bar			
		Design Duty Pressure	Bar			
		Free Air				
		Noise Level	dB			
14.2	<i>Motor</i>					
		Brand/Make				
		Type				
		Model				
		Serial No				
		Power	kW			
		Voltage/Phase	V/Phase			
		Rated Current	A			
		Speed	Rpm			
		Class				



TESTING AND COMMISSIONING  
PLAN FOR WATER TREATMENT  
PLANT

Contract No:

Rev: 1

Date:

**Appendix**

	<b>TESTING AND COMMISSIONING PLAN FOR WATER TREATMENT PLANT</b>	Contract No:
		Rev: 1
		Date:

PRE-COMMISSIONING CHECKLIST FOR WATER TREATMENT PLANT

**Appendix (A)**

**PRE-COMMISSIONING CHECKLISTS FOR WATER TREATMENT PLANTS**



## TESTING AND COMMISSIONING PLAN FOR WATER TREATMENT PLANT

Contract No:

Rev: 1

Date:

### PRE-COMMISSIONING CHECKLIST FOR WATER TREATMENT PLANT

Project Name :	Capacity :	m <sup>3</sup> /hr
Work Contract No. :	Operation :	hr/d
<b>INTAKE</b>		
<u>General</u>	Yes	No
1. Installation/assembly complete and in accordance with drawings		
2. Forebays and sumps free from construction debris		
3. Screens cleaned		
4. Penstocks operated over full travel		
5. Penstocks tested for leaks at high river level		
6. Pump discharge valves: Operated over full travel		
7. Pump discharge NRV's: Correctly installed		
8. Raw water pipeline: Valves operated over full travel		
9. Raw water pipeline: Pressure test completed (see attached sheets)		
10. Cables: Insulation/termination checks completed (see attached data sheets)		
11. Surge protection checked		
<u>Lifting Gear</u>		
1. Safe Working Load painted on lifting gear .....Tonnes		
2. Chain lubricated		
3. Load hook operated over full travel		
4. Raw water pumps: Removed and installed		
5. For 'A' frame: Travelled full length with pump		
Travelled full width with pump		
6. Paintwork satisfactorily/made good		
<u>Pumps</u>		
1. Pump manufacturers pre-start up checks complete (see attached sheets)	Yes	No
Pump		
Pump		
Pump		
Pump		



**TESTING AND COMMISSIONING  
PLAN FOR WATER TREATMENT  
PLANT**

Contract No:

Rev: 1

Date:

**PRE-COMMISSIONING CHECKLIST FOR WATER TREATMENT PLANT**

2. Raw water pipeline ready to receive and dispose of water			
3. Intake sump: Adequate water level			
4. Intake sumps LLS electrode checked and operational (test by shorting link)			
5. MCC function check (main fused removed)			
<b>Motors</b>			
1. Pump motor insulation resistance check ( $\geq 20$ MegaOhm)	R (M $\Omega$ )	Y (M $\Omega$ )	B (M $\Omega$ )
	Pump		
	Pump		
	Pump		
2. Switchgear over current protection set at :			
	Pump		A
	Pump		A
	Pump		A
	Pump		A
		Yes	No
1. Motor winding thermister checked			
2. Pump/motor rotation check: (CCW/CW)	Pump		
	Pump		
	Pump		
	Pump		
3. Earth conductivity tests carried out ( see attached data sheets)			
Above checks satisfactorily completed			
	Checked Sub-Contractor	Supervised by Consultant	Witnessed by JBALB Representatives
Name			
Signature			
Designation			
Date			



**TESTING AND COMMISSIONING  
PLAN FOR WATER TREATMENT  
PLANT**

Contract No:

Rev: 1

Date:

**PRE-COMMISSIONING CHECKLIST FOR WATER TREATMENT PLANT**

Project Name :		Capacity : m3/hr	
Work Contract No. :		Operation : hr/d	
<b>AERATOR</b>		Yes	No
1. Installation/assembly complete and in accordance with drawings.			
2. Aerator channels and chambers cleared of construction debris and flushed through.			
3. Aerator inlet and drain valves operated over full travel.			
4. Leakage test completed.			
5. Check dosing points in accordance with drawings.			
Above checks satisfactorily completed.			
	Checked Sub-Contractor	Supervised by Consultant	Witnessed by JBALB Representatives
Name			
Signature			
Designation			
Date			



**TESTING AND COMMISSIONING  
PLAN FOR WATER TREATMENT  
PLANT**

Contract No:

Rev: 1

Date:

**PRE-COMMISSIONING CHECKLIST FOR WATER TREATMENT PLANT**

Project Name :	Capacity :	m <sup>3</sup> /hr	
Work Contract No. :	Operation :	hr/d	
<b>FLOCCULATORS</b>		Yes	No
1. Installation/assembly complete and in accordance with drawings			
2. All clarifier channels, sumps and pipes flushed through			
3. Overflows and drains ready to receive and dispose of water			
4. All valves operated over full travel			
5. Path of scraper assembly checked for obstruction; clearance.....			
6. Scraper paintwork checked			
7. Scraper torque limit switch set	Unit No.		
	Unit No.		
	Unit No.		
8. Gearbox oil levels checked:	Unit No. Flocc G/bx A		
	Flocc G/bx B		
	Scraper G/bx		
	Unit No. Flocc G/bx A		
	Flocc G/bx B		
	Scraper G/bx		
	Unit No. Flocc G/bx A		
	Flocc G/bx B		
	Scraper G/bx		
9. Switchgear over current protection	Unit No. Flocc G/bx A		
set at MCC:	Flocc G/bx B		
	Scraper G/bx		
	Unit No. Flocc G/bx A		
	Flocc G/bx B		
	Scraper G/bx		
	Unit No. Flocc G/bx A		
	Flocc G/bx B		
	Scraper G/bx		



**TESTING AND COMMISSIONING  
PLAN FOR WATER TREATMENT  
PLANT**

Contract No:

Rev: 1

Date:

**PRE-COMMISSIONING CHECKLIST FOR WATER TREATMENT PLANT**

10. Motor Insulation Resistance checks ( $\geq 20$ MegaOhm)	R (M $\Omega$ )	Y (M $\Omega$ )	B (M $\Omega$ )
Unit No. Flocc G/bx A			
Flocc G/bx B			
Scraper G/bx			
Unit No. Flocc G/bx A			
Flocc G/bx B			
Scraper G/bx			
		Yes	No
11. Rotation correct (CCW/CW) Unit No.	Flocc G/bx A		
	Flocc G/bx B		
	Scraper G/bx		
Unit No.	Flocc G/bx A		
	Flocc G/bx B		
	Scraper G/bx		
Unit No.	Flocc G/bx A		
	Flocc G/bx B		
	Scraper G/bx		
Above checks completed satisfactorily :			
Unit No.			
Unit No.			
Unit No.			
Remarks:			
	Checked Sub-Contractor	Supervised by Consultant	Witnessed by JBALB Representatives
Name			
Signature			
Designation			
Date			



**TESTING AND COMMISSIONING  
PLAN FOR WATER TREATMENT  
PLANT**

Contract No:

Rev: 1

Date:

**PRE-COMMISSIONING CHECKLIST FOR WATER TREATMENT PLANT**

Project Name :		Capacity :	m <sup>3</sup> /hr
Work Contract No. :		Operation :	hr/d
<b>FLOCCULATOR/CLARIFIERS</b>		Yes	No
1. Installation/assembly complete and in accordance with drawings.			
2. All flocculator/clarifier channels, sumps, pipes, spaces and launders cleared of construction debris, and flushed through.			
3. Penstocks and valves operated over full travel.			
4. Overflows and drains ready to receive and dispose of water.			
5. Leakage test carried out (see attached cert.)			
Above checks completed satisfactorily:			
Unit No.			
Unit No.			
Unit No.			
Remarks:			
	Checked Sub-Contractor	Supervised by Consultant	Witnessed by JBALB Representatives
Name			
Signature			
Designation			
Date			



**TESTING AND COMMISSIONING  
PLAN FOR WATER TREATMENT  
PLANT**

Contract No:

Rev: 1

Date:

**PRE-COMMISSIONING CHECKLIST FOR WATER TREATMENT PLANT**

Project Name :		Capacity :		m <sup>3</sup> /hr		
Work Contract No. :		Operation :		hr/d		
<b>RAPID GRAVITY FILTERS</b>				Yes	No	
1. Installation/assembly complete and in accordance with drawings						
2. All channels, sumps, pipes and spaces cleared of construction debris						
3. Penstocks and valves tested over full travel						
4. Overflows, drains and weir ready to receive water						
5. Pipework pressure tests completed (see attached cert.)						
6. Tank leakage test completed (see attached cert.)						
7. Filter media placed, levelled, depth checked						
depth of gravel						
depth of sand						
Test results for media, see attached sheets						
8. Wash water weir level check						
Weir length %	Filter No.	Filter No.	Filter No.	Filter No.	Filter No.	Filter No.
0						
33						
67						
100						
Within tolerance + <u>3</u> m				Yes	No	
9. Inlet penstock weir level checked						
10. Air blower delivery rate ( from manufacturers cert.)						



**TESTING AND COMMISSIONING  
PLAN FOR WATER TREATMENT  
PLANT**

Contract No:

Rev: 1

Date:

**PRE-COMMISSIONING CHECKLIST FOR WATER TREATMENT PLANT**

Above checks completed satisfactorily :	Yes	No
Unit No.		
Unit No.		
Unit No.		
Unit No.		
Unit No.		
Unit No.		

	Checked Sub-Contractor	Supervised by Consultant	Witnessed by JBALB Representatives
Name			
Signature			
Designation			
Date			



## TESTING AND COMMISSIONING PLAN FOR WATER TREATMENT PLANT

Contract No:

Rev: 1

Date:

### PRE-COMMISSIONING CHECKLIST FOR WATER TREATMENT PLANT

Project Name :	Capacity : m3/hr		
Work Contract No. :	Operation : hr/d		
<b>BACKWASH PUMPS</b>			
	Yes	No	
1. Installation/assembly complete and in accordance with drawings			
2. Pumps suction/discharge valves operated over full travel			
3. Pumps NRV's correctly installed			
4. Air release isolating valves operated over full travel			
5. Pipeline pressure tests complete (see attached cert.)			
6. Cables: Insulation/determination checks complete (see data sheet.....)			
7. Adequate level in balance tank			
8. Coupling alignment checks			
	Pump No.	Parallel (mm)	Angular (mm)
Pipework coupled	Pump	/	/
	Pump	/	/
	Pump	/	/
Pipework uncoupled	Pump	/	/
	Pump	/	/
	Pump	/	/
Manufacturers permitted tolerance:			
Parallel (mm)			
Angular (mm)			
Values within permitted range:		Yes	No
Pump			
Pump			
Pump			
	Sub-Contractor	Supervised by Consultant	Witnessed by JBALB
Name			
Signature			
Designation			
Date			



**TESTING AND COMMISSIONING  
PLAN FOR WATER TREATMENT  
PLANT**

Contract No:

Rev: 1

Date:

**PRE-COMMISSIONING CHECKLIST FOR WATER TREATMENT PLANT**

Project Name :		Capacity : m <sup>3</sup> /hr	
Work Contract No. :		Operation : hr/d	
<u>MOTORS</u>	R (MΩ)	Y (MΩ)	B (MΩ)
Motor insulation resistance check ( $\geq 20$ MegaOhm)			
1. Pump			
Pump			
Pump			
2. Switchgear over current protection set at;			
Pump		Amps	
Pump		Amps	
Pump		Amps	
3. Pump/motor rotation check carried out; (CCW/CW)		Yes	No
Pump			
Pump			
Pump			
4. Earth conductivity tests carried out (see data sheet.....)			
Remarks:			
	Checked Sub-Contractor	Supervised by Consultant	Witnessed by JBALB Representatives
Name			
Signature			
Designation			
Date			



**TESTING AND COMMISSIONING  
PLAN FOR WATER TREATMENT  
PLANT**

Contract No:

Rev: 1

Date:

**PRE-COMMISSIONING CHECKLIST FOR WATER TREATMENT PLANT**

Project Name :		Capacity : m <sup>3</sup> /hr	
Work Contract No. :		Operation : hr/d	
<b>TREATED WATER PUMPS</b>		Yes	No
1. Installation/assembly complete and in accordance with drawings			
2. Pumps suction/discharge valves operated over full travel			
3. Pumps NRV's correctly installed			
4. Air release isolating valves operated over full travel			
5. Pipeline pressure tests complete (see attached cert.)			
6. Cables: Insulation/determination test complete (see attached data sheet)			
7. Adequate water level in balance tank			
8. Coupling alignment checks			
	Pump No.	Parallel (mm)	Angular (mm)
Pipework uncoupled	Pump	/	/
	Pump	/	/
	Pump	/	/
	Pump	/	/
Pipework coupled	Pump	/	/
	Pump	/	/
	Pump	/	/
	Pump	/	/

Values within manufacturers range	Yes	No



**TESTING AND COMMISSIONING  
PLAN FOR WATER TREATMENT  
PLANT**

Contract No:

Rev: 1

Date:

**PRE-COMMISSIONING CHECKLIST FOR WATER TREATMENT PLANT**

<u>MOTORS</u>			
1. Motor insulation resistance check ( $\geq 20$ Megaohm)	R (M $\Omega$ )	Y (M $\Omega$ )	B (M $\Omega$ )
	Pump		
	Pump		
	Pump		
	Pump		
2. Switchgear over current set		Unit	Current (A)
		Pump	
		Pump	
		Pump	
		Pump	
		Pump	
3. Pump/motor rotation check:		Clockwise (CW)	Counter clockwise (CW)
		Pump	
		Pump	
		Pump	
		Pump	
		Pump	
		Pump	
		Yes	No
4. Earth continuity checks carried out (see attached data sheet )			
5. Low level shut-off probes checked (by shorting)			
Above checks satisfactorily completed			
	Checked Sub-Contractor	Supervised by Consultant	Witnessed by JBALB Representatives
Name			
Signature			
Designation			
Date			



**TESTING AND COMMISSIONING  
PLAN FOR WATER TREATMENT  
PLANT**

Contract No:

Rev: 1

Date:

**PRE-COMMISSIONING CHECKLIST FOR WATER TREATMENT PLANT**

Project Name :		Capacity : m <sup>3</sup> /hr		
Work Contract No. :		Operation : hr/d		
<b>AIR BLOWERS</b>			Yes	No
1. Installation/assembly complete and in accordance with drawings				
2. All valves operated over full travel				
3. NRV's correctly installed				
4. Belt alignment/tension check (see manufacturers instruction attached)			Blower	
			Blower	
5. Cables: Insulation/determination checks complete (see data sheets...)				
<b>MOTOR</b>				
6. Insulation resistance checked				
		R(MΩ)	Y (MΩ)	B (MΩ)
	Blower			
	Blower			
7. Switchgear over current protection set			Units	Amps
			Blower	
			Blower	
8. Blower/motor rotation check:			Units	Clockwise (CW)
				Counterclockwise (CCW)
			Blower	
			Blower	
9. Earth continuity checks carried out ( see data sheet.....)				
Above checks satisfactorily completed.				
	Checked Sub-Contractor	Supervised by Consultant	Witnessed by JBALB Representatives	
Name				
Signature				
Designation				
Date				



**TESTING AND COMMISSIONING  
PLAN FOR WATER TREATMENT  
PLANT**

Contract No:

Rev: 1

Date:

**PRE-COMMISSIONING CHECKLIST FOR WATER TREATMENT PLANT**

Project Name :		Capacity : m <sup>3</sup> /hr		
Work Contract No. :		Operation : hr/d		
<p align="center"><b>MOTIVE WATER PUMPS (Submersible Pump)</b></p> <p>1. Installation/assembly complete and in accordance with drawings</p> <p>2. Pumps suction/discharge valves operated over full travel</p> <p>3. Pump NRV's correctly installed</p> <p>4. Air release isolating valves operated over full travel</p> <p>5. Eductor isolating valves operated over full travel</p> <p>6. Pipeline pressure tests complete (see attached cert.)</p> <p>7. Cables: Insulation/determination tests complete (see data sheet.....)</p>			Yes	No
8. Measure motor insulation resistance ( $\geq 20$ MegaOhm)				
	Unit No.	R (M $\Omega$ )	Y (M $\Omega$ )	B (M $\Omega$ )
	Motor			
	Motor			
9. Switchgear over current protection set		Units	Amps	
		Pump		
		Pump		
10. Earth continuity checks carried out ( see data sheet.....)				
Above checks satisfactorily completed.				
	Checked Sub-Contractor	Supervised by Consultant	Witnessed by JBALB Representatives	
Name				
Signature				
Designation				
Date				



**TESTING AND COMMISSIONING  
PLAN FOR WATER TREATMENT  
PLANT**

Contract No:

Rev: 1

Date:

**PRE-COMMISSIONING CHECKLIST FOR WATER TREATMENT PLANT**

Project Name :	Capacity : m <sup>3</sup> /hr
Work Contract No. :	Operation : hr/d

**BACKWASH TANK (CLEAR WATER TANK)**

1. Installation/assembly complete and in accordance with drawings
2. Tank clean internally and free from construction debris
3. Valves operated over full travel.
4. Pipework pressure tests complete. (see attached cert.)
5. Airvent clear, screen in position.
6. Surface coating checked.
7. Tank leakage test complete (see attached cert.)
8. Tank disinfection complete (see attached cert.)

Yes	No

Above checks satisfactorily completed, system ready for use.

	Checked Sub-Contractor	Supervised by Consultant	Witnessed by JBALB Representatives
Name			
Signature			
Designation			
Date			



## TESTING AND COMMISSIONING PLAN FOR WATER TREATMENT PLANT

Contract No:

Rev: 1

Date:

### PRE-COMMISSIONING CHECKLIST FOR WATER TREATMENT PLANT

Project Name :	Capacity :	m <sup>3</sup> /hr
Work Contract No. :	Operation :	hr/d
<b>CONTACT/BALANCE TANK ( ML Reservoir )</b>	Yes	No
1. Installation/assembly complete and in accordance with drawings.		
2. All channels, sumps, pipes and spaces cleared of construction debris and flushed through.		
3. Valves operated over full travel.		
4. Over flows and drains ready to receive and dispose of water.		
5. Surface coating checked ( where applicable ).		
6. Pipeline pressure tests complete (see attached cert.).		
7. Tank leakage test complete (see attached cert.).		
8. Tank disinfection complete (see attached cert.).		
9. Check adequacy of drainage under conditions of overflow and tank drain down, satisfactory.		
10. Time taken to drain unit from full.		
Above checks satisfactorily completed, system ready for use.		
	Checked Sub-Contractor	Supervised by Consultant
Name		Witnessed by JBALB Representatives
Signature		
Designation		
Date		



**TESTING AND COMMISSIONING  
PLAN FOR WATER TREATMENT  
PLANT**

Contract No:

Rev: 1

Date:

**PRE-COMMISSIONING CHECKLIST FOR WATER TREATMENT PLANT**

Project Name :	Capacity :	m <sup>3</sup> /hr	
Work Contract No. :	Operation :	hr/d	
<b>SLUDGE TANK</b>		Yes	No
<u>General</u>			
1. Installation/assembly complete and in accordance with drawings			
2. Tank/sump free from construction debris			
3. Pumps discharge valves operated over full travel			
4. Pump discharge NRV's correctly installed			
5. Pipeline tests complete (see attached cert.)			
6. Cables: Insulation/determination tests complete (see data sheet.....)			
<u>Lifting Gear</u>			
1. SWL.....painted on lighting gear			
2. Chain lubricated			
3. Load hook operated over full travel			
4. Sludge pumps removed and re-installed			
5. Paint work made good			
<u>Pumps</u>			
1. Pump manufacturers pre-start up checks complete (see attached sheets)	Pump		
	Pump		
	Pump		
2. Adequate water level in tank			
3. LLS electrode checked (by shorting link)			
<u>Motors</u>			
1. Motor insulation resistance check ( $\geq 20$ MegaOhm):			
	Unit	R (M $\Omega$ )	Y (M $\Omega$ )
	Pump		
	Pump		
	Pump		



**TESTING AND COMMISSIONING  
PLAN FOR WATER TREATMENT  
PLANT**

Contract No:

Rev: 1

Date:

**PRE-COMMISSIONING CHECKLIST FOR WATER TREATMENT PLANT**

2. Switchgear over current protection set;	Pump	Amps	
	Pump	Amps	
	Pump	Amps	
3. Pump rotation check: correct		Yes	No
	Pump		
	Pump		
	Pump		
4. Earth continuity tests carried out (see attached data sheet.....)			
Above checks satisfactorily completed.			
	Checked Sub-Contractor	Supervised by Consultant	Witnessed by JBALB Representatives
Name			
Signature			
Designation			
Date			



**TESTING AND COMMISSIONING  
PLAN FOR WATER TREATMENT  
PLANT**

Contract No:

Rev: 1

Date:

**PRE-COMMISSIONING CHECKLIST FOR WATER TREATMENT PLANT**

Project Name :		Capacity :		m3/hr
Work Contract No. :		Operation :		hr/d
<b>ALUM DOSING SYSTEM</b>			Yes	No
1. Installation/assembly complete and in accordance with drawings				
2. Tanks and pipework free from construction debris				
3. All valves operated over full travel				
4. NRV's correctly installed				
5. Mixing tank linings, visually checked.				
6. Leakage test complete (see attached cert. )				
7. Cables: Insulation/determination tests complete (see data sheet.....)				
8. Mixer motors insulation resistance ( $\geq 20$ MegaOhm)				
	Unit No.	R (M $\Omega$ )	Y (M $\Omega$ )	B (M $\Omega$ )
	Motor			
	Motor			
9. Switchgear over current protection set:			Unit No.	Current (A)
			Motor	
			Motor	
			Yes	No
10. Earth continuity checks carried out (see attached data sheet.....)				
Above checks satisfactorily completed.				
	Checked Sub- Contractor	Supervised by Consultant	Witnessed by JBALB Representatives	
Name				
Signature				
Designation				
Date				



**TESTING AND COMMISSIONING  
PLAN FOR WATER TREATMENT  
PLANT**

Contract No:

Rev: 1

Date:

**PRE-COMMISSIONING CHECKLIST FOR WATER TREATMENT PLANT**

Project Name :		Capacity :		m3/hr
Work Contract No. :		Operation :		hr/d
<b>SODA ASH DOSING SYSTEM</b>			Yes	No
1. Installation/assembly complete and in accordance with drawings.				
2. Tanks and pipework free from construction debris.				
3. All valves operated over full travel.				
4. Cables: Insulation/determination tests complete (see data sheet.....)				
5. 'V' notch weirs adjusted over full travel.				
6. Hopper vibrator air gap set at 2.54mm.			Feeder	
			Feeder	
7. Hopper vibrator timer set		Unit	Duration	Interval
		Feeder		
		Feeder 2		
8. Hopper heater timer set			Unit	Temperature (°C)
			Feeder	
			Feeder	
9. Motor insulation resistance checked ( $\geq 20$ MegaOhm)				
	Unit No.	R (M $\Omega$ )	Y (M $\Omega$ )	B (M $\Omega$ )
	Feeder			
	Feeder			
	Mixer			
	Mixer			
	Vibrator			
	Vibrator			
10. Switchgear over current protection set:		Unit No.		Current (A)
		Feeder		
		Feeder		
		Mixer		
		Mixer		
		Vibrator		
		Vibrator		



**TESTING AND COMMISSIONING  
PLAN FOR WATER TREATMENT  
PLANT**

Contract No:

Rev: 1

Date:

**PRE-COMMISSIONING CHECKLIST FOR WATER TREATMENT PLANT**

11. Dust extractor fan motor insulation check

	R (MΩ)	Y (MΩ)	B (MΩ)

12. Fan motor over current protection set

Amps

Above checks satisfactorily completed.

	Checked Sub-Contractor	Supervised by Consultant	Witnessed by JBALB Representatives
Name			
Signature			
Designation			
Date			



## TESTING AND COMMISSIONING PLAN FOR WATER TREATMENT PLANT

Contract No:

Rev: 1

Date:

### PRE-COMMISSIONING CHECKLIST FOR WATER TREATMENT PLANT

Project Name :	Capacity : m <sup>3</sup> /hr		
Work Contract No. :	Operation : hr/d		
<b>CHLORINE DOSING SYSTEM</b>			
	Yes      No		
1. Installation/assembly complete and in accordance with drawings			
2. Valves operated over full travel			
3. Cables: Insulation/determination tests complete (see data sheet.....)			
4. Chlorine gas detector: installed and operative			
5. Chlorine gas exhaust fan operational			
Insulation resistance check	R (MΩ)      Y (MΩ)      B (MΩ)		
Over current protection set	Amps      Amps      Amps		
	Rated FLC (A)      Measured FLC (A)		
Measure running current	R      Y      B		
	Yes      No		
6. Hazard warning labels fitted outside chlorine room and chlorine store			
7. Safety wall chart:	Yes      No		
a) Operation of chlorine equipment			
b) Location of safety/First Aid Equipment			
c) First Aid Instructions			
8. First Aid Kit complete and in place			
9. Safety clothing, respirators/breathing apparatus in place and functioning			
10. Cylinder weighing balance checked			
Above checks satisfactorily completed.			
	Checked Sub-Contractor	Supervised by Consultant	Witnessed by JBALB Representatives
Name			
Signature			
Designation			
Date			



**TESTING AND COMMISSIONING  
PLAN FOR WATER TREATMENT  
PLANT**

Contract No:

Rev: 1

Date:

**PRE-COMMISSIONING CHECKLIST FOR WATER TREATMENT PLANT**

Project Name :		Capacity : m3/hr	
Work Contract No. :		Operation : hr/d	
<b>OVERHEAD TRAVELLING CRANE</b>		Yes	No
1. Installation/assembly complete and in accordance with drawings			
2. Tapes over breather holes removed			
3. All damaged paintwork repaired			
4. Alignment check ( N.A. to monorail hoists )			
	Drawing Dim.	Measured Dim.	Permitted Total
Crane span at each of cars			
Diagnostic Controls of crane wheels			
Crane span at rail level			
		Yes	No
5. Safe working load.....painted on frame			
	Location of crane	Safe Working Load (kg)	
Above checks satisfactorily completed.			
	Checked Sub-Contractor	Supervised by Consultant	Witnessed by JBALB Representatives
Name			
Signature			
Designation			
Date			



## TESTING AND COMMISSIONING PLAN FOR WATER TREATMENT PLANT

Contract No:

Rev: 1

Date:

### PRE-COMMISSIONING CHECKLIST FOR WATER TREATMENT PLANT

Project Name :	Capacity : <span style="float: right;">m3/hr</span>	
Work Contract No. :	Operation : <span style="float: right;">hr/d</span>	
<p><b>GENERATORS</b></p> <p>1. Manufacturers pre-start checks</p> <p style="padding-left: 40px;">Completed</p> <p>2. Insulation Tests (Resistance in Mohms) (see attached data sheet.....)</p> <p style="padding-left: 20px;">a) Between load terminals and plant structure</p> <p style="padding-left: 20px;">b) Between generator terminals and structure</p> <p style="padding-left: 20px;">c) Between generator phases</p> <p style="padding-left: 20px;">d) Ancilliary equipment: Heaters</p> <p>3. Continuity tests: Phase and circuit connections checked</p> <p>4. Earthing protection check</p> <p style="padding-left: 20px;">a) Earth resistance on electrical system</p> <p style="padding-left: 20px;">b) Polarity verified</p> <p style="padding-left: 20px;">c) Generator neutral earthing</p>	Generator Unit	
		Measured                      Required
		➤ 50
		➤ 50
		R-Y                      ➤ 50
		Y-B                      ➤ 50
		B-R                      ➤ 50
		➤ 1
		Yes                      No
		Measured                      Required
		➤ 1 ohm
		Yes                      No
	Yes                      No	
<p>5. Battery checks</p> <p style="padding-left: 20px;">a) Standing voltage measured</p> <p style="padding-left: 20px;">b) Starting voltage measured</p> <p style="padding-left: 20px;">c) Specific gravity</p> <p style="padding-left: 20px;">d) Level of electrolyte</p> <p style="padding-left: 20px;">e) Trickle charger checked for correct operation</p>	Measured	
	Volts	
	Volts	
	Amps	
	Yes                      No	
<p>6. Fuel system</p> <p style="padding-left: 20px;">a) Fuel tank level sensors checked for correct operation of pump and alarms</p> <p style="padding-left: 20px;">b) Fuel lines purged of air</p>		



**TESTING AND COMMISSIONING  
PLAN FOR WATER TREATMENT  
PLANT**

Contract No:

Rev: 1

Date:

**PRE-COMMISSIONING CHECKLIST FOR WATER TREATMENT PLANT**

7. Before starting	Yes	No	
a) All lubrication systems checked as correct			
b) Ambient temperature of area			
c) Cooling water gauge reading	Yes	No	
8. Fire/safety	Yes	No	
a) Fire extinguishers installed and fully charged			
b) Fire fuel shut-off valve checked ( remove fusible link )			
Above checks satisfactorily completed.			
	Checked Sub-Contractor	Supervised by Consultant	Witnessed by JBALB Representatives
Name			
Signature			
Designation			
Date			



**TESTING AND COMMISSIONING  
PLAN FOR WATER TREATMENT  
PLANT**

Contract No:

Rev: 1

Date:

**PRE-COMMISSIONING CHECKLIST FOR WATER TREATMENT PLANT**

Project Name :	Capacity :	m <sup>3</sup> /hr		
Work Contract No. :	Operation :	hr/d		
<b>SURGE SUPPRESSION EQUIPMENT</b>				
		Yes	No	
1. Installation/assembly complete and in accordance with drawings				
2. Valves operated over full travel				
3. Cables: Insulation/determination tests complete				
4. Compressors:	Comp.	Comp.		
Manufacturers pre-start up checks complete (see attached sheets )				
5. Pipeline length		m		
6. Double orifice vented NRV's: No.				
7. Double orifice inflow check NRV's: No.				
8. Vessel size		m <sup>3</sup>		
9. Outlet size		mm		
10. Outlet NRV		Yes/No		
11. Normal operating pressure		kPA		
12. PRV setting		kPA		
13. Maximum surge pressure		kPA		
14. Minimum surge pressure		kPA		
	High		Low	
	Rated	Act	Rated	Act
15. Alarm settings high/low	mm	mm	mm	mm
	Stop		Start	
	Rated	Act	Rated	Act
16. Compressor settings stop/start	mm	mm	mm	mm
17. JKKP type approval	Yes/No			
18. JKKP installation approval	Yes/No/NA			



**TESTING AND COMMISSIONING  
PLAN FOR WATER TREATMENT  
PLANT**

Contract No:

Rev: 1

Date:

**PRE-COMMISSIONING CHECKLIST FOR WATER TREATMENT PLANT**

Above checks satisfactorily completed.

	Checked Sub-Contractor	Supervised by Consultant	Witnessed by JBALB Representatives
Name			
Signature			
Designation			
Date			



**TESTING AND COMMISSIONING  
PLAN FOR WATER TREATMENT  
PLANT**

Contract No:

Rev: 1

Date:

**PRE-COMMISSIONING CHECKLIST FOR WATER TREATMENT PLANT**

Project Name :	Capacity :	m3/hr
Work Contract No. :	Operation :	hr/d
<b>INSTRUMENTATION</b>	Yes	No
<u>Flow Measurement</u>		
1. Installation/assembly complete and in accordance with drawings		
2. Control cables insulation check ( see attached sheets.....)		
3. Isolation and balancing valves, bleed screws checked for operation over full stroke		
Raw water		
Inlet flow ( Treated water flow)		
Backwash flow		
Air scour flow		
4. Instrument lines clear of obstruction, flushed through and checked for leaks		
Raw water		
Inlet flow ( Treated water flow)		
Backwash flow		
Air scour flow		
5. Check zero calibration of primary loop element: With balancing valves on DP transmitter open, energise supply to instruments and measure loop current after 10 minutes		
	Expected	Actual
Raw water	4,00 mA	mA
Inlet flow ( Treated water flow)	4,00 mA	mA
Backwash flow	4,00 mA	mA
Air scour flow	4,00 mA	mA
<p>If a value differs from that expected by more than <math>\pm 0,01</math> mA, reconfirm sensor range with D.P. range stamped on Dall Tube/Orifice Plate, then refer to manufacturers operating instructions for procedure to set zero and coarse span.</p>		



## TESTING AND COMMISSIONING PLAN FOR WATER TREATMENT PLANT

Contract No:

Rev: 1

Date:

### PRE-COMMISSIONING CHECKLIST FOR WATER TREATMENT PLANT

N.B. The fine span is pre-set at the factory and should not be adjusted unless there is reason to suspect an unexpected change in calibration. A precision pressure source is required before adjusting the fine span potentiometer.

6. Check integrator accuracy:

With the current loop set at 20mA, measure the time taken for the flow integrator (totaliser) to register an increase of exactly 10 m<sup>3</sup>. Convert this measure to an accuracy (% of full scale).

(See attached sheet for readings and calculation )

%

Backwash flow

Treated water flow

Permitted error :  $\pm 2\%$

Level Measurement

Yes

No

1. Installation/assembly complete and in accordance with drawings

2. Control cables insulation check ( see attached sheets.....)

3. Check zero calibration of primary loop element:

With tank empty, or with transducer lifted clear of the water, energise supply to instruments and measure loop current after 10 minutes.

Expected

Actual

Backwash tank

4,00 mA

mA

Contact/balance tank

4,00 mA

mA

If a measured value differs from that expected by more than  $\pm 0,01$  mA, refer to the manufacturers' operating instructions for the procedure to adjust the zero.

N.B. Integral transducer/transmitters such as model no. SH3102 have no provision for zero adjustment, they are supplied pre-calibrated.

4. Check span of primary loop element:

With tank full, and with transducer lowered to the bottom of the tank such that the depth of water above the transducer is as specified on the Instrument Data Sheet (.....), measure the loop current.



**TESTING AND COMMISSIONING  
PLAN FOR WATER TREATMENT  
PLANT**

Contract No:

Rev: 1

Date:

**PRE-COMMISSIONING CHECKLIST FOR WATER TREATMENT PLANT**

	Expected	Actual
Backwash tank	20,00 mA	mA
Contact/balance tank	20,00 mA	mA

If a measured value differs from that expected by more than  $\pm 0,02$  mA, refer to the manufacturers operating instruction for the procedure to adjust the span (range)

N.B. Integral transducer/transmitters such as model no. SH3102 have no provision for span adjustment, they are supplied pre-calibrated.

Above checks satisfactorily completed.

	Checked Sub-Contractor	Supervised by Consultant	Witnessed by JBALB Representatives
Name			
Signature			
Designation			
Date			



**TESTING AND COMMISSIONING  
PLAN FOR WATER TREATMENT  
PLANT**

Contract No:

Rev: 1

Date:

**PRE-COMMISSIONING CHECKLIST FOR WATER TREATMENT PLANT**

Project Name :	Capacity : m <sup>3</sup> /hr
Work Contract No. :	Operation : hr/d

**CLARITY BOWL/SAMPLING SYSTEM**

General

1. Check installation in accordance with drawings.
2. Isolating valves tested over full travel.
3. All hose clips securely tightened.
4. Clarity bowl unit drain in place.
5. Clarity blows labelled '**Raw Water**', '**Clarified Water**' and '**Filtered Water**'.

Sample Pumps

1. Cables: Insulation/determination checks complete ( see data sheet.....)

2. Motor insulation resistance ( $\geq 20$ MegaOhm )

Unit	M $\Omega$
RW	
SW	
FW	
TW	

3. Switchgear over current protection set at:

Unit	Amps
RW	
SW	
FW	
TW	

4. Pump/motor rotation checks carried out correct.

Unit	Clockwise (CW)	Counterclockwise (CCW)
RW		
SW		
FW		
TW		



**TESTING AND COMMISSIONING  
PLAN FOR WATER TREATMENT  
PLANT**

Contract No:

Rev: 1

Date:

**PRE-COMMISSIONING CHECKLIST FOR WATER TREATMENT PLANT**

Above checks satisfactorily completed.

	Checked Sub- Contractor	Supervised by Consultant	Witnessed by JBALB Representatives
Name			
Signature			
Designation			
Date			



**TESTING AND COMMISSIONING  
PLAN FOR WATER TREATMENT  
PLANT**

Contract No:

Rev: 1

Date:

**CABLE CHECK SHEET**

Project Name: .....				Capacity: .....			m <sup>3</sup> /hr	
Work Contract No.: .....				Operation: .....			hr/d	
Site Location  Power/Control Cables								
Cable Tag	From	To	Cable Type	Rated Voltage (V)	Rated Current (A)	Resistance (Ω)	Loading (kW)	Voltage Drop (V)
Values should exceed 1 MΩ								
The above checks have been completed satisfactorily.								
			Checked By Contractor	Certified by Consultant		Witnessed by JBALB Representative		
Name								
Signature								
Designation								
Date								